

***TM 9-2320-347-10**

TECHNICAL MANUAL OPERATOR'S MANUAL FOR

TRUCK, CARGO, 8X8 M977A2 W/WINCH NSN 2320-01-493-3774 (EIC B2M) M977A2 W/O WINCH NSN 2320-01-493-3779 (EIC B2P)

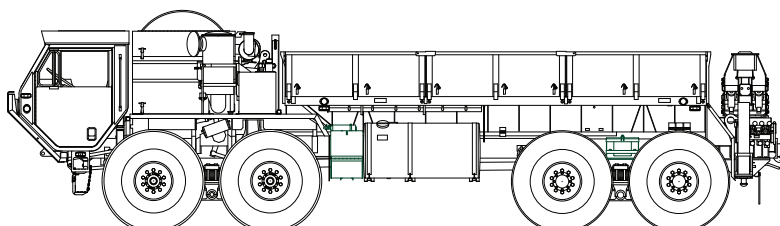

*SUPERSEDURE NOTICE - TM 5-4210-249-13&P-1, TM 5-4210-249-13&P-2, TM 5-4210-249-13&P-3 and TM 5-4210-249-13&P-4 dated 20 Feb 09; EM 0289, TM 9-2320-325-14&P, TM 9-2320-347-10, TM 9-2320-348-10, TM 9-2320-349-10, TM 9-2320-420-10, TM 9-2320-421-10-1, TM 9-2320-421-10-2, TM 9-2320-422-10, TM 9-2320-423-10, TM 9-2320-424-10, TM 9-2320-425-10, TM 9-2320-325-10-HR dated 15 May 2009, Supersedes EM 0232, TM 9-2320-315-14&P, TM 9-2320-315-10, TM 9-2320-315-20 TM 9-2320-315-34, TM 9-2320-315-24P dated 15 Oct 04 and TM 9-2320-279-10-HR, dated 15 Feb 02.

DISTRIBUTION STATEMENT A: Approved for public release; distribution is unlimited.

**HEADQUARTERS, DEPARTMENT OF THE ARMY
MAY 2009**

WARNING SUMMARY

GENERAL SAFETY CAUTION/WARNING SUMMARY

- This list summarizes critical warnings. They are repeated here to let you know how important they are.
- Study these warnings carefully.
- They can save your life and the lives of personnel you work with.
- If there is any doubt about handling tools, materials, equipment, and procedures, see TB 43-0216, Safety and Hazard Warnings for Operation and Maintenance of TACOM Equipment.

Table 1. Warning Icons Used In This Manual.





WARNING ICON	DESCRIPTION
	<p><u>AIR PRESSURE</u> - human hand blocking air gun shows the need to reduce air pressure before use, or debris may injure user and/or damage equipment.</p>
	<p><u>BIOLOGICAL</u> - abstract symbol bug shows that a material may contain bacteria or viruses that present a danger to life or health.</p>
	<p><u>CHEMICAL</u> - drops of liquid on hand show that the material will cause burns or irritation to human skin or tissue.</p>
	<p><u>CRYOGENIC</u> - hand in block of ice shows that the material is extremely cold and can injure human skin and tissue.</p>

Table 1. Warning Icons Used In This Manual. - Continued





WARNING ICON	DESCRIPTION
	<p><u>ELECTRICAL</u> - electrical wire to arm with electricity symbol running through human body shows that shock hazard is present.</p>
	<p><u>EXPLOSION</u> - rapidly expanding symbol shows that the material may explode if subjected to high temperatures, sources of ignition, or high pressure.</p>
	<p><u>EXTREMELY COLD SURFACE</u> - hand touching object with ice formed on both shows that surface is extremely cold and can damage human tissue.</p>
	<p><u>EYE PROTECTION</u> - person with goggles shows that the material will injure the eyes.</p>
	<p><u>FIRE</u> - flame shows that material may ignite and cause burns.</p>

Table 1. Warning Icons Used In This Manual. - Continued





WARNING ICON	DESCRIPTION
	<p><u>FIRE EXTINGUISHER</u> - fire extinguisher shows that material may ignite and a fire extinguisher should be within easy reach.</p>
	<p><u>HEAVY OBJECT</u> - human figure stooping over heavy object shows physical injury potential for improper lifting technique, and/or aid of assistant(s) and/or lifting device (as required).</p>
	<p><u>HEAVY PARTS</u> - hand with heavy object on top shows that heavy parts can crush and harm.</p>
	<p><u>HEAVY PARTS</u> - foot with heavy object on top shows that heavy parts can crush and harm.</p>
	<p><u>HEAVY PARTS</u> - moving heavy object pinning human figure against stationary object shows that heavy, moving parts/objects present a danger to life or limb.</p>

Table 1. Warning Icons Used In This Manual.





WARNING ICON	DESCRIPTION
	<p><u>HEAVY PARTS</u> - heavy object on human figure shows that heavy parts present a danger to life or limb.</p>
	<p><u>HOT AREA</u> - hand over object radiating heats shows that part is hot and can burn.</p>
	<p><u>MOVING PARTS</u> - hand with fingers caught between gears shows that the moving parts of the equipment present a danger to life or limb.</p>
	<p><u>PRESSURE/TENSION HAZARD</u> - human body being impacted by rotating projectile shows that equipment is under pressure or tension presenting a danger to life or limb if pressure or tension is not carefully released.</p>
	<p><u>PROJECTILE HAZARD</u> - human body with object passing through it shows that a projectile hazard exists.</p>

Table 1. Warning Icons Used In This Manual.





WARNING ICON	DESCRIPTION
	<p><u>RADIATION</u> - three circular wedges show that the material emits radioactive energy and can injure human tissue.</p>
	<p><u>ROLLOVER HAZARD</u> - vehicle indicating direction of human figure shows that vehicle may roll over if conditions are not avoided, presenting a danger to life or limb.</p>
	<p><u>RUN OVER HAZARD</u> - vehicle running over human body shows hazard.</p>
	<p><u>SHARP OBJECT</u> - pointed object in hand shows that a sharp object presents a danger to life or limb.</p>
	<p><u>SKIN IRRITATION</u> - hand radiating shows that material can cause skin irritation.</p>

Table 1. Warning Icons Used In This Manual.







WARNING ICON	DESCRIPTION
	<p><u>SLICK FLOOR</u> - wavy line on floor with legs prone shows that slick floor presents a danger of falling.</p>
	<p><u>STEAM HAZARD</u> - human engulfed in steam cloud shows steam hazard exists that could injure/burn human tissue.</p>
	<p><u>TIRE BLOWOUT</u> - tire with hole shows that an over or under inflated tire may rupture, presenting a danger to life or limb.</p>
	<p><u>VAPOR</u> - human figure in a cloud shows that material vapors present a danger to life or health.</p>
	<p><u>WARNING/CAUTION</u> - triangle with exclamation point within shows that a WARNING or CAUTION is present that indicates a potential hazard, which may cause injury or death to personnel (warning), or damage to equipment (caution).</p>

Table 1. Warning Icons Used In This Manual.

WARNING ICON	DESCRIPTION
	<p><u>WIRE CABLE/ROPE</u> - human hand with frayed wire cable/rope running across shows injury to unprotected (bare) hands may result.</p>
	<p><u>EAR PROTECTION</u> - headphones over ears show that noise level will harm ears.</p>

FOR INFORMATION ON FIRST AID:

Reference FM 4-25.11. (WP 0161)

WARNING



MODIFICATION HAZARD

- Unauthorized modifications to, alterations to, or installations on this equipment are prohibited and are in violation of AR 750-10.
- Failure to comply may result in injury or death to personnel or damage to equipment.

WARNING



HIGH-PRESSURE HYDRAULIC SYSTEM

- Hydraulic systems can cause serious injuries if high-pressure lines or equipment fails.
- Never work on hydraulic systems or equipment unless there is another person nearby who is familiar with the operation and hazards of the equipment and can give first aid.
- Never disconnect any hydraulic hose or part while the engine is running. Allow several minutes to elapse after shutting off engine, to allow pressure to relieve itself, before attempting to remove hoses. Failure to comply may result in injury to personnel.
- The HEMTT vehicles contain hydraulic systems operating at oil pressures up to 3,000 psi (20 685 kPa) and 3,200 psi (22 064 kPa). Never disconnect any hydraulic line or fitting without first dropping the pressure to zero. Failure to comply may result in serious injury or death to personnel.

WARNING



ELECTRICAL SYSTEM

- Remove all jewelry, such as rings, ID tags, bracelets, etc. If jewelry or tools contact electrical circuits, a direct short may result. Failure to comply may result in serious injury or death to personnel.
- Do not smoke, use open flame, make sparks or other ignition sources around batteries. A battery giving off gas could explode. Failure to comply may result in serious injury or death to personnel.
- Be careful when working on or with electrical equipment. Do not be misled by the term "low voltage". Voltages as low as 50 volts can cause death. For artificial respiration, refer to FM 4-25.11.
- When working inside the vehicle with power off, be sure to ground every capacitor likely to hold a dangerous voltage potential.

- Never work on electronic equipment unless there is another person nearby who is familiar with the operation and hazards of the equipment.

WARNING



SOLVENT CLEANING COMPOUND

- Solvent cleaning compound MIL-PRF-680 Type II and III may be irritating to the eyes and skin. Use protective gloves and goggles. Use in a well-ventilated area. Use respirator as needed. Accidental ingestion can cause irritation of digestive tract and respiratory tract, may cause lung and central nervous system damage. Can be fatal if swallowed. Inhalation of high/massive concentrations can cause coma or be fatal. First aid for ingestion: do not induce vomiting. Seek immediate medical attention. First aid of skin contact: remove contaminated clothing. Wash skin thoroughly with soap and water. If symptoms persist, seek medical attention. First aid for eye contact: flush with water for 15 minutes or until irritation subsides. If symptoms persist, seek medical attention. First aid for inhalation: move to fresh air. If not breathing, provide artificial respiration. If symptoms persist, seek medical attention. Keep away from open flames and other sources of ignition. Failure to follow this warning may result in injury or death to personnel.
- The flashpoint for Type II solvent cleaning compound is 141 to 198°F (61 to 92°C), and Type III is 200 to 241°F (93 to 116°C).
- Improper cleaning methods and use of unauthorized cleaning solvents may injure personnel and damage equipment.
- Fire extinguishers should be placed nearby when using solvent cleaning compound. Failure to follow this warning may result in injury or death.
- Cloths or rags saturated with solvent cleaning compound must be disposed of IAW authorized facilities' procedures. Failure to follow this warning may result in injury.
- Eye shields must be worn when cleaning with a wire brush. Flying rust and metal particles may cause injury.

WARNING**POLYURETHANE COATING (CARC)**

- Eye and hearing protection must be worn at all times when using power tools for grinding, cutting, sawing, and drilling. Failure to do so may result in injury to personnel. Chemical Agent Resistant Coating (CARC) paint contains isocyanate which is highly irritating to skin and respiratory system. High concentrations of isocyanate can produce symptoms of itching and reddening of skin, a burning sensation in the throat and nose, and watering of the eyes. In extreme concentrations, isocyanate can cause cough, shortness of breath, pain during respiration, increased sputum production, and chest tightness. First aid for ingestion: do not induce vomiting. Seek immediate medical attention. First aid for skin contact: remove contaminated clothing. Wash skin thoroughly with soap and water. If symptoms persist, seek medical attention. First aid for eye contact: flush with water for 15 minutes or until irritation subsides. If symptoms persist, seek medical attention. First aid for inhalation: move to fresh air. If not breathing, provide artificial respiration. If symptoms persist, seek medical attention.
- The following precautions must be taken whenever using CARC paint:
- Protective equipment (gloves, goggles, ventilation mask) must be worn when using CARC paint.
- NEVER cut CARC-coated materials without high-efficiency, air-purifying respirators in use.
- DO NOT grind or sand painted equipment without high-efficiency, air-purifying respirators in use.
- BE AWARE of CARC paint exposure symptoms; symptoms can occur a few days after initial exposure. Seek medical help immediately if symptoms are detected.
- Use only in well-ventilated area. Check with local environmental office for methods and locations approved for painting in accordance with local and state environmental regulations.
- Always use air line respirators when using CARC paint unless air sampling shows exposure to be below standards. Use chemical cartridge respirator if air sampling is below standards.

WARNING



ADHESIVE

- Adhesive, solvents and sealing compounds can burn easily and are harmful causing immediate bonding on contact with eyes, skin, or clothing and gives off harmful vapors.
- If adhesive, solvent, or sealing compound gets on skin or clothing, wash immediately with soap and water.
- If adhesive gets in your eyes, try to keep them open; flush them with water for 15 minutes and get immediate medical attention.
- Wear protective goggles and use in a well-ventilated area.
- Keep away from open fire and use in well-ventilated area to avoid injury or death.

WARNING



FLAMMABLE LIQUID AND COMBUSTIBLE VAPOR

- Gasoline, fuel oil, lubricating oil, grease, paint, paint thinner, cleaning solvents, and other combustible liquids present a serious fire hazard.
- Combustible liquids must ALWAYS be stored in their approved containers and designated compartments or deck storage locations.
- Ensure exhaust and ventilation fans are operating while using cleaning solvents or paint products.
- Never store or charge batteries in a confined space without ventilation or near electrical equipment.
- Fuel is very flammable and can explode easily.
- To avoid serious injury or death, keep fuel away from open fire and keep fire extinguisher within easy reach when working with fuel.
- Do not work on fuel system when engine is hot. Fuel can be ignited by hot engine.

- When working with fuel, post signs that read NO SMOKING WITHIN 50 FEET OF VEHICLE.
- Starting fluid is toxic and flammable. Do not store in cab and do not breathe fumes. Do not puncture or burn containers. Dispose of container following manufacturer's recommendations on the container.

WARNING



LIFTING OPERATIONS This section is applicable to all lifting operations regardless of lifting equipment (crane, LHS, etc.) used.

- All personnel must stand clear during lifting operations. A swinging or shifting load may cause injury or death to personnel.
- Never crawl under equipment when performing maintenance unless equipment is securely blocked. Failure to comply may cause injury or death to personnel.
- Keep clear of equipment when it is being raised or lowered. Failure to comply may cause injury or death to personnel.
- Do not work on any item supported only by lift jacks or hoist. Always use blocks or proper stands to support the item prior to any work. Failure to comply may result in injury or death to personnel.
- Do not lift a load greater than the rated load capacity of the crane or materiel handling equipment. Failure to comply may result in injury or death to personnel or damage to equipment.
- Do not allow heavy components to swing while hanging by lifting device. Failure to comply may cause injury or death to personnel.
- Any part or component that weighs between 50 lbs (23 kg) and 75 lbs (34 kg) must be removed with the aid of an assistant. Any part or component that weighs over 75 lbs (34 kg) must be removed with the aid of an assistant and a lifting device. Failure to comply may cause injury or death to personnel.
- Ensure all chains, hooks, and slings are in good condition and are of correct capacity. Ensure hooks are positioned correctly. Failure to comply may result in injury or death to personnel.

WARNING

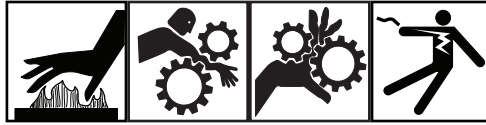

MOVING MACHINERY

- Use extreme care when operating or working near moving machinery including running engine, rotating shafts, and other moving parts. Failure to comply may result in injury or death to personnel.
- Use extreme care when measuring voltage while engine is running around rotating fan blade and hot engine parts. Failure to comply may result in injury or death to personnel.

WARNING

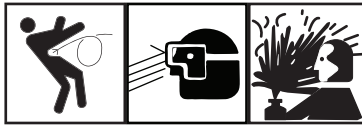

PARTS UNDER PRESSURE

- Wear safety goggles and use caution when removing or installing springs, snap rings, retaining rings, and other parts under spring tension. These parts can act as projectiles. Failure to comply may result in injury or death to personnel.
- The radiator is very hot and pressurized during vehicle operation. Let radiator cool before removing cap. Failure to do so can result in serious burns.
- During pressure tests, ensure air pressure is drained to 0 psi (0 kPa) before taking off any components. If pressure is not released, plates or line could blow off and harm personnel. Do not drain air from tank with any part of body in air spray path. Skin embolisms and/or debris in eyes can occur from released pressure.
- High air pressure may be released from valve stem when valve core is removed. Stay clear of valve stem after core is removed. Ensure all personnel wear suitable eye protection. Failure to comply may result in injury to personnel.
- Stand clear of trajectory area during deflation or personal injury or death may result.

- Lock-ring is under tension. If lock-ring breaks loose it could cause injury to personnel. Keep hands and fingers away from lock-ring when removing.
- Never adjust relief valve so that personnel must stand on strongback to operate latch.
- If there is any residual pressure in tank when relief valve is open, personnel may lose their balance and fall. Failure to comply may result in injury or death to personnel.
- Use extreme care when removing or installing spring retainers. Spring retainers are under tension and can act as projectiles when released suddenly. Ensure proper eye protection is worn to prevent injury to personnel.
- Use extreme care when removing or installing springs. Springs are under tension and can act as projectiles when released. Ensure proper eye protection is worn to prevent injury to personnel. Eye protection is required during all grinding operations. Failure to comply may result in serious injury to personnel.
- Failure to relieve tank pressure may result in sudden, unexpected loss of pressure. Failure to comply may result in personal injury or death.
- Do not remove the radiator cap when the engine is hot, as steam and hot coolant can escape. Failure to comply may result in personal injury or death.

WARNING



HEAVY PARTS

Any part or component that weigh over 50 lbs (23 kg) must be removed with the aid of an assistant and a lifting device. Failure to comply may result in personal injury or death.

WARNING

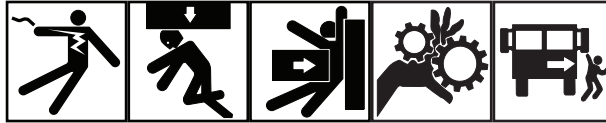

CRANE SYSTEM

- Always refer to the range diagram BEFORE making any lift. It is extremely important that the crane is properly leveled to prevent oversteering.
- Do not operate crane unless outriggers are set up. Always chock front wheels when using outriggers. Failure to comply may result in injury or death to personnel.
- When using crane on any vehicle, park vehicle clear of all overhead powerlines. If operating crane under power lines, do not allow vehicle to contact high-voltage connections. Failure to comply will result in death to personnel.
- Do not stand under crane. Failure to comply may result in injury or death to personnel.
- Refuse to work with worn, frayed, or damaged wire rope. Always wear heavy gloves when handling winch cables; never let cable run through hands. Frayed cables can cut. Never operate winch with less than five wraps of cable on winch drum. Failure to comply may result in injury or death to personnel.
- When using crane on any vehicle, park vehicle clear of all overhead power lines. Do not operate crane near overhead power lines. Failure to comply may result in injury or death to personnel.
- Boom has a 370 degree rotation and is mechanically stopped at five degrees on either side of the left outrigger beam. Swing operations must be slowed no later than 15 degrees prior to contacting the stop.
- Keep boom clear of electrical powerlines and other obstacles. Do not operate crane near overhead powerlines. Failure to comply will result in death to personnel.
- Avoid quick, jerking, winch operation. Keep other personnel well away from vehicles involved in winching operations. A snapped cable or shifting load can cause serious injury or death.
- If possible, keep one hand away from equipment to reduce the hazard of current flowing through vital organs of the body.
- Keep fingers clear of top of lift-hook. Failure to comply could result in personnel injury.

WARNING



CARBON MONOXIDE (EXHAUST GAS) CAN CAUSE DEATH

- Carbon monoxide does not have color or smell and can cause death.
- Breathing air with carbon monoxide produces symptoms of headache, dizziness, loss of muscular control, a sleepy feeling and coma. Brain damage or death can result from heavy exposure.
- Carbon monoxide is in exhaust fumes of fuel-burning heaters and internal combustion engines.
- Carbon monoxide can become dangerously concentrated under conditions of no ventilation.
- Precautions must be followed to ensure crew safety when the personnel heater or engine of any vehicle is operated for any purpose. Failure to comply may result in injury or death to personnel.
- DO NOT operate vehicle engine in a closed place unless the place has proper ventilation. Failure to comply may result in injury or death to personnel.
- DO NOT drive any vehicle with inspection plates, cover plates, or engine compartment covers removed unless necessary for maintenance purposes. Failure to comply may result in injury or death to personnel.
- BE ALERT at all times during vehicle operation for exhaust odors and exposure symptoms. If either odor or exposure symptoms are present, IMMEDIATELY VENTILATE personnel compartments. If symptoms continue, remove affected crew to fresh air and keep warm. DO NOT PERMIT PHYSICAL EXERCISE. If necessary, give artificial respiration and get immediate medical attention. For artificial respiration, refer to FM 4-25.11 . Failure to comply may result in injury or death to personnel.
- BE AWARE that the gas particulate filter unit or the field protection mask for nuclear-biological-chemical protection WILL NOT offer safety from carbon monoxide poisoning.

WARNING



EXTREME HEAT

If required to remain inside the vehicle during extreme heat, occupants should follow the water intake, work/rest cycle, and other heat stress preventive medicine measures contained in FM 21-10, Field Hygiene and Sanitation.

WARNING



CABLES

- Always wear heavy gloves when handling winch cables; never let cable run through hands. Frayed cables can cut. Failure to comply may result in injury or death to personnel.
- Never operate winch with less than five wraps of cable on winch drum. Frayed cables can cut. Failure to comply may result in injury or death to personnel.

WARNING



LEAD-ACID BATTERIES

- Wear proper eye protection when working around batteries. Failure to comply may result in injury or death to personnel.
- Use extreme care not to short out battery terminals. Remove all jewelry such as rings, ID tags, bracelets, etc. prior to working on or

around vehicle. Jewelry and tools can catch on equipment, contact positive electrical circuits, and cause a direct short, severe burns, or electrical shock. Failure to comply may result in injury or death to personnel.

- Batteries produce explosive gases. Do not smoke or use open flame near batteries. Do not allow hot, sparking, or glowing objects near batteries. If batteries are giving off gases, presence of a heat, flame, or spark may cause fire and/or explosion. Failure to comply may result in injury or death to personnel.
- Battery electrolyte is harmful to skin, and eyes. Avoid battery electrolyte contact with skin, eyes, or clothing. If battery electrolyte spills, take immediate action to stop burning effects:

WARNING



NBC

- NBC-contaminated air filters must be handled and disposed of only by authorized and trained personnel.
- The unit commander or senior officer in charge of maintenance personnel must ensure that prescribed protective clothing (FM 3-11.4) is used, and prescribed safety measures and decontamination procedures (FM 3-11.5) are followed.
- The local unit SOP is responsible for final disposal of contaminated air filters. Failure to comply may cause severe injury or death to personnel.

WARNING



TIRE OPERATION

- Operating a vehicle with a tire in an overinflated or underinflated condition, or with a questionable defect, may lead to premature tire failure. Ensure tire has proper tire pressure. Failure to comply may result in injury or death to personnel.

- When inflating tires mounted on the vehicle, all personnel must remain out of trajectory of the side ring and lock-ring as shown by the areas indicated. Failure to follow proper procedures may result in serious injury or death to personnel.
- Cracked, broken, bent or otherwise damaged rim components shall not be reworked, welded, brazed, or otherwise heated or damage or personal injury or death may result.
- No heat shall be applied to a multi-piece wheel or wheel component or damage or injury or death may result.
- Failure to place wheel/tire assembly in safety cage prior to initial inflation could result in serious injury or death to personnel.
- When a wheel/tire is in a restraining device, do not rest or lean any part of body or equipment on or against the restraining device, or injury or death could result.
- While changing tires or while performing tire maintenance, stay out of the trajectory path. Failure to comply may result in injury or death to personnel.
- Always use an inflation hose with an in-line gauge and a clip-on chuck when inflating tires. The gauge and valve must be mounted a minimum of 10 feet (3.10 m) away from air chuck.
- High air pressure may be released from valve stem when valve core is removed. Stay clear of valve stem after core is removed. Ensure all personnel wear suitable eye protection. Failure to comply may result in injury to personnel.
- Tire is heavy. Brace tire to ensure tire will not fall over on you or on others.

WARNING



VEHICLE OPERATION

- Speed limits posted on curves reflect speeds that are considered safe for automobiles. Heavy trucks with a high center of gravity can roll over at these speed limits. Use caution and reduce your speed below the posted limit before entering a curve. Failure to comply may result in vehicle crash and injury to personnel.

- Use caution and reduce your speed below the posted limit before entering a curve. Failure to comply may result in vehicle crash and injury to personnel.
- Always use seatbelts when operating vehicle. Failure to use seatbelt can result in serious injury or death in case of accident.
- Operation at speeds over 15 mph (24 kph) on paved roads can be achieved when the operator determines that the vehicle being towed and the terrain allow safe operation.
- Under no condition can speeds over 35 mph (55 kph) on paved road and 15 mph (24 kph) off-road be allowed. Loss of control can cause serious injury or death. Excessive speed can cause damage to vehicle being towed.

WARNING



BRAKES

- Ensure all personnel are clear from front of truck before performing brake stall check. Be ready to apply service brake. Operator must remain in cab while performing this check. Failure to comply could result in personnel injury.
- Never use parking brake for normal braking or wheels will lock up causing severe skid. Skidding vehicle may result in serious personal injury or death.
- Engine must be shut OFF and parking brake set before performing PMCS walkaround. Failure to comply may result in injury or death to personnel.

WARNING



BURNS

The exhaust pipe and muffler can become very hot during vehicle operation. Be careful not to touch these parts with bare hands, or allow

body to come in contact with exhaust pipe or muffler. Exhaust system parts can become hot enough to cause serious burns.

WARNING



HEARING PROTECTION

- Excessive noise levels are present any time the heavy-duty winch or crane is operating.
- Wear single hearing protection (earplugs or equivalent) while working around equipment while it is running. Failure to do so could result in damage to your hearing.
- Seek medical aid should you suspect a hearing problem.

WARNING

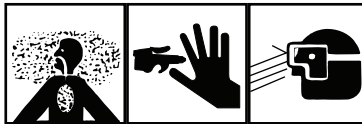

COMPRESSED AIR

- Brake shoes may be coated with dust. Breathing this dust may be harmful to your health.
- Do not use compressed air to clean brake shoes. Wear a filter mask approved for use against brake dust. Failure to comply may result in injury or death to personnel.
- Compressed air used for cleaning purposes will not exceed 30 psi (207 kPa).
- Use only with effective chip guarding and personal protective equipment, goggles, shield, and gloves.

LIST OF EFFECTIVE PAGES/WORK PACKAGES

NOTE:

This manual supersedes TM 9-2320-315-14&P, dated 15 October 2004. Zero in the "Change No." column indicates an original page or work package.

Date of issue for the original manual is:

Original 15 May 2009

**TOTAL NUMBER OF PAGES FOR FRONT AND REAR
MATTER IS 78 AND TOTAL NUMBER OF WORK PACKAGES
IS 164, CONSISTING OF THE FOLLOWING:**

Page/WP No.	Change No.	Page/WP No.	Change No.
Front Cover	0	WP 0022 (8 pages)	0
Warning Summary	0	WP 0023 (2 pages)	0
i-xliv	0	WP 0024 (2 pages)	0
Chp 1 - General Information, Equipment Description and Theory of Operation	0	WP 0025 (2 pages)	0
WP 0001 (12 pages)	0	WP 0026 (4 pages)	0
WP 0002 (10 pages)	0	WP 0027 (4 pages)	0
WP 0003 (2 pages)	0	WP 0028 (4 pages)	0
WP 0004 (4 pages)	0	WP 0029 (2 pages)	0
WP 0005 (2 pages)	0	WP 0030 (4 pages)	0
WP 0006 (10 pages)	0	WP 0031 (2 pages)	0
WP 0007 (2 pages)	0	WP 0032 (4 pages)	0
WP 0008 (4 pages)	0	WP 0033 (2 pages)	0
WP 0009 (4 pages)	0	WP 0034 (4 pages)	0
WP 0010 (2 pages)	0	WP 0035 (6 pages)	0
WP 0011 (2 pages)	0	WP 0036 (4 pages)	0
WP 0012 (14 pages)	0	WP 0037 (4 pages)	0
WP 0013 (6 pages)	0	WP 0038 (4 pages)	0
WP 0014 (2 pages)	0	WP 0039 (2 pages)	0
WP 0015 (2 pages)	0	WP 0040 (8 pages)	0
WP 0016 (2 pages)	0	WP 0041 (24 pages)	0
Chp 2 - Operator Instructions	0	WP 0042 (26 pages)	0
WP 0017 (2 pages)	0	WP 0043 (14 pages)	0
WP 0018 (4 pages)	0	WP 0044 (10 pages)	0
WP 0019 (2 pages)	0	WP 0045 (2 pages)	0
WP 0020 (8 pages)	0	WP 0046 (2 pages)	0
WP 0021 (8 pages)	0	WP 0047 (2 pages)	0
		WP 0048 (8 pages)	0
		WP 0049 (2 pages)	0

Page/WP No.	Change No.	Page/WP No.	Change No.
WP 0050 (2 pages)	0	WP 0094 (6 pages)	0
WP 0051 (4 pages)	0	WP 0095 (2 pages)	0
WP 0052 (6 pages)	0	WP 0096 (6 pages)	0
WP 0053 (2 pages)	0	WP 0097 (4 pages)	0
WP 0054 (4 pages)	0	WP 0098 (2 pages)	0
WP 0055 (4 pages)	0	WP 0099 (2 pages)	0
WP 0056 (2 pages)	0	WP 0100 (6 pages)	0
WP 0057 (2 pages)	0	WP 0101 (4 pages)	0
WP 0058 (4 pages)	0	WP 0102 (8 pages)	0
WP 0059 (8 pages)	0	WP 0103 (2 pages)	0
WP 0060 (4 pages)	0	WP 0104 (2 pages)	0
WP 0061 (2 pages)	0	WP 0105 (4 pages)	0
WP 0062 (2 pages)	0	WP 0106 (8 pages)	0
WP 0063 (2 pages)	0	Chp 3 - Troubleshooting	
WP 0064 (2 pages)	0	Procedures	0
WP 0065 (4 pages)	0	WP 0107 (12 pages)	0
WP 0066 (2 pages)	0	WP 0108 (8 pages)	0
WP 0067 (4 pages)	0	WP 0109 (8 pages)	0
WP 0068 (4 pages)	0	WP 0110 (4 pages)	0
WP 0069 (4 pages)	0	WP 0111 (6 pages)	0
WP 0070 (2 pages)	0	WP 0112 (6 pages)	0
WP 0071 (2 pages)	0	WP 0113 (4 pages)	0
WP 0072 (2 pages)	0	WP 0114 (4 pages)	0
WP 0073 (2 pages)	0	WP 0115 (8 pages)	0
WP 0074 (6 pages)	0	WP 0116 (8 pages)	0
WP 0075 (4 pages)	0	WP 0117 (6 pages)	0
WP 0076 (4 pages)	0	WP 0118 (4 pages)	0
WP 0077 (2 pages)	0	WP 0119 (4 pages)	0
WP 0078 (2 pages)	0	WP 0120 (4 pages)	0
WP 0079 (2 pages)	0	WP 0121 (6 pages)	0
WP 0080 (4 pages)	0	WP 0122 (4 pages)	0
WP 0081 (2 pages)	0	WP 0123 (4 pages)	0
WP 0082 (16 pages)	0	WP 0124 (4 pages)	0
WP 0083 (4 pages)	0	WP 0125 (8 pages)	0
WP 0084 (8 pages)	0	WP 0126 (4 pages)	0
WP 0085 (4 pages)	0	WP 0127 (6 pages)	0
WP 0086 (2 pages)	0	WP 0128 (4 pages)	0
WP 0087 (38 pages)	0	WP 0129 (6 pages)	0
WP 0088 (2 pages)	0	WP 0130 (4 pages)	0
WP 0089 (4 pages)	0	WP 0131 (8 pages)	0
WP 0090 (2 pages)	0	WP 0132 (6 pages)	0
WP 0091 (18 pages)	0	WP 0133 (4 pages)	0
WP 0092 (4 pages)	0	WP 0134 (4 pages)	0
WP 0093 (4 pages)	0	WP 0135 (2 pages)	0

Page/WP No.	Change No.	Page/WP No.	Change No.
WP 0136 (4 pages)	0	WP 0152 (4 pages)	0
WP 0137 (6 pages)	0	WP 0153 (6 pages)	0
WP 0138 (2 pages)	0	WP 0154 (2 pages)	0
WP 0139 (2 pages)	0	WP 0155 (20 pages)	0
WP 0140 (6 pages)	0	WP 0156 (2 pages)	0
WP 0141 (4 pages)	0	WP 0157 (6 pages)	0
WP 0142 (4 pages)	0	WP 0158 (8 pages)	0
WP 0143 (2 pages)	0	WP 0159 (6 pages)	0
Chp 4 - Preventive Maintenance		WP 0160 (4 pages)	0
Checks and Services (PMCS)	0	Chp 6 - Supporting Information	0
WP 0144 (4 pages)	0	WP 0161 (8 pages)	0
WP 0145 (38 pages)	0	WP 0162 (12 pages)	0
WP 0146 (4 pages)	0	WP 0163 (6 pages)	0
WP 0147 (44 pages)	0	WP 0164 (8 pages)	0
WP 0148 (54 pages)	0		
WP 0149 (28 pages)	0		
WP 0150 (16 pages)	0		
Chp 5 - Maintenance			
Instructions	0		
WP 0151 (14 pages)	0		

**HEADQUARTERS
DEPARTMENT OF THE ARMY
WASHINGTON, D.C., 15 MAY 2009**

TECHNICAL MANUAL

**OPERATOR'S MANUAL for
TRUCK, CARGO, 8X8
M977A2, W/WINCH (NSN 2320-01-493-3774)(EIC B2M)
M977A2, W/O WINCH (NSN 2320-01-493-3779)(EIC B2P)**

REPORTING ERRORS AND RECOMMENDING IMPROVEMENTS

You can help improve this publication. If you find any errors, or if you would like to recommend any improvements to the procedures in this publication, please let us know. The preferred method is to submit your DA Form 2028 (Recommended Changes to Publications and Blank Forms) through the Internet, on the Army Electronic Product Support (AEPS) website. The Internet address is <https://aeps.ria.army.mil>. The DA Form 2028 is located under the Public Applications section in the AEPS Public Home Page. Fill out the form and click on SUBMIT. Using this form on the AEPS will enable us to respond quicker to your comments and better manage the DA Form 2028 program. You may also mail, e-mail, or fax your comments or DA Form 2028 directly to the U.S. Army TACOM Life Cycle Management Command. The postal mail address is U.S. Army TACOM Life Cycle Management Command, ATTN: AMSTA-LC-LMPP / TECH PUBS, 1 Rock Island Arsenal, Rock Island, IL 61299-7630. The e-mail address is tacomlcmc.daform2028@us.army.mil. The fax number is DSN 793-0726 or Commercial (309) 782-0726.

SUPERSEDURE NOTICE - TM 5-4210-249-13&P-1, TM 5-4210-249-13&P-2, TM 5-4210-249-13&P-3 and TM 5-4210-249-13&P-4 dated 20 Feb 09; EM 0289, TM 9-2320-325-14&P, TM 9-2320-347-10, TM 9-2320-348-10, TM 9-2320-349-10, TM 9-2320-420-10, TM 9-2320-421-10-1, TM 9-2320-421-10-2, TM 9-2320-422-10, TM 9-2320-423-10, TM 9-2320-424-10, TM 9-2320-425-10, TM 9-2320-325-10-HR dated 15 May 2009 Supersedes EM 0232, TM 9-2320-315-14&P, TM 9-2320-315-10, TM 9-2320-315-20 TM 9-2320-315-34, TM 9-2320-315-24P dated 15 Oct 04 and TM 9-2320-279-10-HR, dated 15 Feb 02.
DISTRIBUTION STATEMENT A: Approved for public release; distribution is unlimited.

TABLE OF CONTENTS

	<u>WP Sequence No.</u>
	<u>Page No.</u>
Warning Summary	
How to Use this Manual	
Chapter 1 - General Information, Equipment Description and Theory of Operation	
INTRODUCTION.....	WP 0001
Table 1. Overview.....	0001-1
Figure 1.	0001-1
Table 2. Common Nomenclature.....	0001-3
Table 3. Common Abbreviations.....	0001-4
Table 4. Significant Hazard And Safety Recommendations.....	0001-10
WARRANTY PROGRAM.....	WP 0002
Table 1. Vehicle Information.....	0002-3
Table 2. Vehicle Information.....	0002-4
EQUIPMENT CHARACTERISTICS, CAPABILITIES, AND FEATURES.....	WP 0003
LOCATION AND DESCRIPTION OF MAJOR COMPONENTS.....	WP 0004
Table 1. HEMTT Series Vehicle Common Component Location.....	0004-1
Figure 1.	0004-1
Table 2. M977A2/M985A2 Cargo Vehicle Specific Component Location.....	0004-3
Figure 2.	0004-3
DIFFERENCES BETWEEN MODELS.....	WP 0005
Table 1. Differences Between HEMTT A2 Models.....	0005-1

TABLE OF CONTENTS - Continued

	<u>WP Sequence No.</u>
	<u>Page No.</u>
Table 2. Notes.....	0005-2
EQUIPMENT DATA.....	WP 0006
Table 1. Vehicle Operation.....	0006-1
Table 2. M977A2 Cargo Vehicle Dimensions.....	0006-1
Table 3. M977A2 Cargo Vehicle Weight.....	0006-1
Table 4. M977A2 Cargo Vehicle Weight.....	0006-2
Table 5. M977A2 Cargo Vehicle Weight Distribution.....	0006-2
Table 6. M977A2 Cargo Vehicle Weight Distribution.....	0006-2
Table 7. Vehicle Performance.....	0006-2
Table 8. Fluid Capacities.....	0006-3
Table 9. Engine.....	0006-3
Table 10. Fuel System.....	0006-4
Table 11. Electrical System.....	0006-4
Table 12. Cooling System.....	0006-5
Table 13. Transmission.....	0006-5
Table 14. Transfer Case.....	0006-6
Table 15. Front Tandem Axles.....	0006-6
Table 16. Rear Tandem Axles.....	0006-6
Table 17. Brake System.....	0006-6
Table 18. Wheels.....	0006-7
Table 19. Tires.....	0006-7
Table 20. Steering System.....	0006-7

TABLE OF CONTENTS - Continued

	<u>Page No.</u>	<u>WP Sequence No.</u>
Table 21. Towing Eyes.....	0006-7	
Table 22. Pintle Hook.....	0006-7	
Table 23. Cab.....	0006-8	
Table 24. Self-Recovery Winch.....	0006-8	
Table 25. Material Handling Crane.....	0006-8	
Table 26. Auxiliary Equipment.....	0006-8	
Table 27. M977A2 Cargo Vehicle Load Classification.....	0006-9	
Table 28. Tire Pressures.....	0006-9	
Table 29. Operating Speeds.....	0006-10	
SELF-RECOVERY WINCH.....		WP 0007
Figure 1.	0007-1	
ELECTRICAL SYSTEM.....		WP 0008
Figure 1.	0008-2	
Figure 2.	0008-3	
AIR SYSTEM.....		WP 0009
Figure 1.	0009-2	
MAIN HYDRAULIC SYSTEM.....		WP 0010
Figure 1.	0010-1	
Figure 2.	0010-2	
STEERING SYSTEM.....		WP 0011
Figure 1.	0011-1	
POWER TRAIN.....		WP 0012

TABLE OF CONTENTS - Continued

	<u>Page No.</u>	<u>WP Sequence No.</u>
Figure 1.	0012-2	
Figure 2.	0012-4	
Figure 3.	0012-6	
Figure 4.	0012-8	
Figure 5.	0012-10	
Figure 6.	0012-12	
Figure 7.	0012-13	
Figure 8.	0012-13	
Figure 9.	0012-14	
ENGINE SYSTEMS.....		WP 0013
Figure 1.	0013-1	
Figure 2.	0013-3	
Figure 3.	0013-4	
Figure 4.	0013-5	
Figure 5.	0013-6	
CAB.....		WP 0014
Figure 1.	0014-1	
WHEELS AND TIRES.....		WP 0015
Figure 1.	0015-1	
CRANE.....		WP 0016
Figure 1.	0016-1	

TABLE OF CONTENTS - Continued

	<u>WP Sequence No.</u>
	<u>Page No.</u>
Chapter 2 - Operator Instructions	
CAB-MOUNTED FOOT CONTROLS.....	WP 0017
Table 1. Cab-Mounted Foot Controls.....	0017-1
Figure 1.	0017-1
CAB-MOUNTED HAND CONTROLS.....	WP 0018
Table 1. Cab-Mounted Hand Controls.....	0018-2
Figure 1.	0018-2
STEERING COLUMN MOUNTED CONTROLS.....	WP 0019
Table 1. Steering Column Mounted Controls.....	0019-1
Figure 1.	0019-1
TUNNEL PANEL CONTROLS AND INDICATORS.....	WP 0020
Table 1. Tunnel panel controls and indicators.....	0020-2
Figure 1.	0020-2
Figure 2.	0020-4
Table 2. Tunnel panel controls and indicators.....	0020-5
Figure 3.	0020-5
Figure 4.	0020-7
INSTRUMENT PANEL CONTROLS AND INDICATORS.....	WP 0021
Table 1. Instrument Panel Controls and Indicators.....	0021-2
Figure 1.	0021-2
Figure 2.	0021-4
Figure 3.	0021-6

TABLE OF CONTENTS - Continued

	<u>WP Sequence No.</u>
	<u>Page No.</u>
HEATER COMPARTMENT CONTROLS AND INDICATORS.....	WP 0022
Table 1. Heater Compartment Controls and Indicators.....	0022-1
Figure 1.	0022-1
Figure 2.	0022-4
Figure 3.	0022-6
OPERATOR AND CREW FOUR-POINT SEATBELT/AIR-RIDE SEAT ADJUSTMENT CONTROLS.....	WP 0023
Table 1. Operator and Crew Four-Point Seatbelt/ Air-Ride Seat Adjustment Controls.....	0023-1
Figure 1.	0023-1
24V BATTERY DISCONNECT SWITCH.....	WP 0024
Table 1. 24V Battery Disconnect Switch.....	0024-1
Figure 1.	0024-1
HYDRAULIC SELECTOR VALVE CONTROL.....	WP 0025
Table 1. Hydraulic Selector Valve Control.....	0025-1
Figure 1.	0025-1
GROVE CRANE CONTROL LEVERS.....	WP 0026
Table 1. Grove Crane Control Levers.....	0026-2
Figure 1.	0026-2
GROVE CRANE BOXES AND REMOTE-CONTROL UNIT.....	WP 0027
Table 1. Grove Crane Boxes and Remote-Control Unit.....	0027-2
Figure 1.	0027-2
RIFLE STOWAGE MOUNT.....	WP 0028

TABLE OF CONTENTS - Continued

	<u>Page No.</u>	<u>WP Sequence No.</u>
Table 1. Rifle Stowage Mount.....	0028-2	
Figure 1.	0028-2	
ARCTIC ENGINE HEATER CONTROLS AND INDICATORS.....		WP 0029
Table 1. Arctic Engine Heater Controls And Indicators.....	0029-1	
Figure 1.	0029-1	
GAS PARTICULATE FILTER UNIT (GPFU) CONTROLS AND INDICATORS		WP 0030
Table 1. Gas Particulate Filter Unit (GPFU) Controls And Indicators.....	0030-2	
Figure 1.	0030-2	
MACHINE GUN MOUNT.....		WP 0031
Table 1. Machine Gun Mount.....	0031-2	
Figure 1.	0031-2	
M-8 CHEMICAL ALARM CONTROLS AND INDICATORS.....		WP 0032
Table 1. M-8 Chemical Alarm Controls And Indicators.....	0032-2	
Figure 1.	0032-2	
M-13 DECONTAMINATION KIT.....		WP 0033
Table 1. M-13 Decontamination Kit.....	0033-2	
Figure 1.	0033-2	
RADIO INSTALLATION HARDWARE.....		WP 0034
Table 1. Radio Installation Hardware.....	0034-2	
Figure 1.	0034-2	
OPERATE WINDSHIELD WIPERS/WASHER.....		WP 0035

TABLE OF CONTENTS - Continued

	<u>Page No.</u>	<u>WP Sequence No.</u>
Figure 1.	0035-2	
Figure 2.	0035-3	
Figure 3.	0035-4	
Figure 4.	0035-5	
OPERATE CAB TEMPERATURE CONTROLS.....		WP 0036
Figure 1.	0036-2	
Figure 2.	0036-3	
OPERATE FIRE EXTINGUISHER.....		WP 0037
Figure 1.	0037-2	
Figure 2.	0037-3	
Figure 3.	0037-4	
OPERATE ACCESS LADDER.....		WP 0038
Figure 1.	0038-1	
Figure 2.	0038-2	
Figure 3.	0038-3	
OPERATE DRAIN PLUG.....		WP 0039
Figure 1.	0039-1	
Figure 2.	0039-2	
CONNECT/DISCONNECT TRAILER.....		WP 0040
Figure 1.	0040-2	
Figure 2.	0040-3	
Figure 3.	0040-3	

TABLE OF CONTENTS - Continued

	<u>WP Sequence No.</u>
	<u>Page No.</u>
Figure 4.	0040-4
Figure 5.	0040-5
Figure 6.	0040-6
Figure 7.	0040-7
CARGO BODY OPERATION.....	WP 0041
Figure 1.	0041-2
Figure 2.	0041-4
Figure 3.	0041-6
Figure 4.	0041-7
Figure 5.	0041-8
Figure 6.	0041-9
Figure 7.	0041-10
Figure 8.	0041-11
Figure 9.	0041-12
Figure 10.	0041-12
Figure 11.	0041-13
Figure 12.	0041-13
Figure 13.	0041-14
Figure 14.	0041-14
Figure 15.	0041-15
Figure 16.	0041-16
Figure 17.	0041-17

TABLE OF CONTENTS - Continued

	<u>WP Sequence No.</u>
	<u>Page No.</u>
Figure 18.	0041-18
Figure 19.	0041-19
Figure 20.	0041-19
Figure 21.	0041-20
Figure 22.	0041-20
Figure 23.	0041-21
Figure 24.	0041-21
Figure 25.	0041-22
Figure 26.	0041-22
Figure 27.	0041-23
Figure 28.	0041-23
Figure 29.	0041-24
GROVE CRANE OPERATION (MANUAL CONTROL).....	WP 0042
Figure 1.	0042-3
Figure 2.	0042-4
Figure 3.	0042-5
Figure 4.	0042-5
Figure 5.	0042-7
Figure 6.	0042-8
Figure 7.	0042-8
Figure 8.	0042-9
Figure 9.	0042-10

TABLE OF CONTENTS - Continued

	<u>Page No.</u>	<u>WP Sequence No.</u>
Figure 10.	0042-11	
Figure 11.	0042-12	
Figure 12.	0042-13	
Figure 13.	0042-14	
Figure 14.	0042-15	
Figure 15.	0042-16	
Figure 16.	0042-17	
Figure 17.	0042-18	
Figure 18.	0042-20	
Figure 19.	0042-21	
Figure 20.	0042-22	
Figure 21.	0042-23	
Figure 22.	0042-24	
Figure 23.	0042-24	
Figure 24.	0042-25	
GROVE CRANE OPERATION (REMOTE CONTROL).....		WP 0043
Figure 1.	0043-2	
Figure 2.	0043-3	
Figure 3.	0043-5	
Figure 4.	0043-7	
Figure 5.	0043-8	
Figure 6.	0043-10	

TABLE OF CONTENTS - Continued

	<u>Page No.</u>	<u>WP Sequence No.</u>
Figure 7.	0043-11	
Figure 8.	0043-12	
Figure 9.	0043-13	
Figure 10.	0043-14	
START ENGINE.....		WP 0044
Figure 1.	0044-2	
Figure 2.	0044-3	
Figure 3.	0044-5	
Figure 4.	0044-6	
Figure 5.	0044-8	
Figure 6.	0044-9	
OPERATE PARKING BRAKES.....		WP 0045
Figure 1.	0045-2	
OPERATE SERVICE BRAKES.....		WP 0046
Figure 1.	0046-2	
OPERATE TRAILER BRAKES.....		WP 0047
Figure 1.	0047-2	
OPERATE TRANSMISSION AND TRANSFER CASE.....		WP 0048
Figure 1.	0048-2	
Figure 2.	0048-5	
Figure 3.	0048-7	
OPERATE ENGINE BRAKE.....		WP 0049

TABLE OF CONTENTS - Continued

	<u>Page No.</u>	<u>WP Sequence No.</u>
Figure 1.	0049-2	
DRIVE VEHICLE FORWARD.....		WP 0050
Figure 1.	0050-2	
DRIVE VEHICLE IN REVERSE.....		WP 0051
Figure 1.	0051-2	
DRIVE VEHICLE IN CITY TRAFFIC AND ON HIGHWAY.....		WP 0052
Figure 1.	0052-2	
Figure 2.	0052-3	
Figure 3.	0052-4	
DRIVE VEHICLE IN OFF-ROAD CONDITIONS.....		WP 0053
Figure 1.	0053-1	
DRIVE VEHICLE UP/DOWN STEEP GRADE.....		WP 0054
Figure 1.	0054-1	
Figure 2.	0054-2	
DRIVE VEHICLE IN SLIPPERY CONDITIONS.....		WP 0055
Figure 1.	0055-2	
PARK VEHICLE.....		WP 0056
Figure 1.	0056-1	
SHUT OFF ENGINE.....		WP 0057
Figure 1.	0057-1	
OPERATE ARCTIC ENGINE HEATER.....		WP 0058
Figure 1.	0058-3	

TABLE OF CONTENTS - Continued

	<u>WP Sequence No.</u>
	<u>Page No.</u>
OPERATE GAS PARTICULATE FILTER UNIT (GPFU).....	WP 0059
Figure 1.	0059-2
Figure 2.	0059-3
Figure 3.	0059-3
Figure 4.	0059-4
Figure 5.	0059-5
Figure 6.	0059-5
Figure 7.	0059-6
Figure 8.	0059-7
Figure 9.	0059-7
Figure 10.	0059-8
Figure 11.	0059-8
OPERATE RIFLE STOWAGE MOUNT.....	WP 0060
Figure 1.	0060-2
Figure 2.	0060-3
OPERATE MACHINE GUN MOUNT.....	WP 0061
OPERATE M-8 CHEMICAL ALARM.....	WP 0062
OPERATE M-13 DECONTAMINATION KIT.....	WP 0063
OPERATE RADIO.....	WP 0064
PORTABLE WORK LAMP OPERATION.....	WP 0065
Figure 1.	0065-1
Figure 2.	0065-2

TABLE OF CONTENTS - Continued

	<u>Page No.</u>	<u>WP Sequence No.</u>
Figure 3.	0065-3	
OPERATE DOME LIGHT.....		WP 0066
Figure 1.	0066-2	
OPERATE PANEL LIGHTS.....		WP 0067
Figure 1.	0067-2	
OPERATE PARKING LIGHTS.....		WP 0068
Figure 1.	0068-2	
OPERATE SERVICE DRIVE LIGHTS.....		WP 0069
Figure 1.	0069-1	
Figure 2.	0069-2	
Figure 3.	0069-3	
OPERATE STOPLIGHTS.....		WP 0070
Figure 1.	0070-2	
OPERATE CLEARANCE LIGHTS.....		WP 0071
Figure 1.	0071-1	
OPERATE BLACKOUT DRIVE LIGHT.....		WP 0072
Figure 1.	0072-2	
OPERATE BLACKOUT MARKERS.....		WP 0073
Figure 1.	0073-2	
PORTABLE BEACON LIGHT OPERATION.....		WP 0074
Figure 1.	0074-1	
Figure 2.	0074-2	

TABLE OF CONTENTS - Continued

	<u>Page No.</u>	<u>WP Sequence No.</u>
Figure 3.	0074-3	
Figure 4.	0074-4	
Figure 5.	0074-5	
OPERATE TURN SIGNALS.....		WP 0075
Figure 1.	0075-2	
OPERATE EMERGENCY FLASHERS.....		WP 0076
Figure 1.	0076-2	
INSTALL/REMOVE WHEEL CHOCKS.....		WP 0077
Figure 1.	0077-1	
Figure 2.	0077-2	
CHANGE VEHICLE WEIGHT INDICATOR.....		WP 0078
Figure 1.	0078-1	
OPERATE 24V BATTERY DISCONNECT SWITCH.....		WP 0079
Figure 1.	0079-1	
ADJUST AIR-RIDE SEAT.....		WP 0080
Figure 1.	0080-2	
OPERATE FOUR-POINT SEATBELT.....		WP 0081
Figure 1.	0081-1	
LIMP HOME/FLAT TIRE WITH NO SPARE.....		WP 0082
Figure 1.	0082-2	
Figure 2.	0082-2	
Figure 3.	0082-3	

TABLE OF CONTENTS - Continued

	<u>WP Sequence No.</u>
	<u>Page No.</u>
Figure 4.	0082-3
Figure 5.	0082-4
Figure 6.	0082-5
Figure 7.	0082-5
Figure 8.	0082-6
Figure 9.	0082-6
Figure 10.	0082-7
Figure 11.	0082-8
Figure 12.	0082-9
Figure 13.	0082-10
Figure 14.	0082-10
Figure 15.	0082-11
Figure 16.	0082-12
Figure 17.	0082-13
Figure 18.	0082-13
Figure 19.	0082-14
Figure 20.	0082-14
Figure 21.	0082-15
PERFORM IMMEDIATE ACTION FOR LOSS OF AIR SUPPLY SYSTEM PRESSURE.....	WP 0083
Figure 1.	0083-1
INSTALL/REMOVE TIRE CHAINS.....	WP 0084

TABLE OF CONTENTS - Continued

	<u>WP Sequence No.</u>
	<u>Page No.</u>
Figure 1.	0084-2
Figure 2.	0084-2
Figure 3.	0084-3
Figure 4.	0084-4
Figure 5.	0084-5
Figure 6.	0084-5
Figure 7.	0084-6
Figure 8.	0084-6
FORD WATER OBSTACLE.....	WP 0085
Figure 1.	0085-2
INTERIM NUCLEAR, BIOLOGICAL, AND CHEMICAL (NBC) DECONTAMINATION PROCEDURES.....	WP 0086
SELF-RECOVER VEHICLE USING SELF-RECOVERY WINCH.....	WP 0087
Figure 1.	0087-1
Figure 2.	0087-2
Figure 3.	0087-3
Figure 4.	0087-4
Figure 5.	0087-4
Figure 6.	0087-5
Figure 7.	0087-6
Figure 8.	0087-7
Figure 9.	0087-8

TABLE OF CONTENTS - Continued

	<u>WP Sequence No.</u>
	<u>Page No.</u>
Figure 10.	0087-9
Table 1. Self-Recovery Winch Pull Capacity.....	0087-10
Figure 11.	0087-12
Figure 12.	0087-14
Figure 13.	0087-16
Figure 14.	0087-17
Figure 15.	0087-18
Figure 16.	0087-19
Figure 17.	0087-20
Figure 18.	0087-21
Figure 19.	0087-22
Figure 20.	0087-22
Figure 21.	0087-23
Figure 22.	0087-24
Figure 23.	0087-25
Figure 24.	0087-25
Figure 25.	0087-26
Figure 26.	0087-27
Figure 27.	0087-28
Table 2. Self-Recovery Winch Pull Capacity.....	0087-29
Figure 28.	0087-30
Figure 29.	0087-31

TABLE OF CONTENTS - Continued

	<u>Page No.</u>	<u>WP Sequence No.</u>
Figure 30.	0087-34	
Figure 31.	0087-34	
Figure 32.	0087-35	
Figure 33.	0087-37	
Figure 34.	0087-37	
SNATCH BLOCK INSTALLATION/REMOVAL.....		WP 0088
Figure 1.	0088-1	
Figure 2.	0088-2	
CONNECT/DISCONNECT SELF-RECOVERY WINCH CABLE TO ANOTHER VEHICLE.....		WP 0089
Figure 1.	0089-1	
Figure 2.	0089-2	
Figure 3.	0089-3	
Figure 4.	0089-4	
TOW DISABLED VEHICLE.....		WP 0090
Figure 1.	0090-2	
CONNECT/DISCONNECT TOW BAR.....		WP 0091
Figure 1.	0091-2	
Figure 2.	0091-3	
Figure 3.	0091-3	
Figure 4.	0091-5	
Figure 5.	0091-7	

TABLE OF CONTENTS - Continued

	<u>Page No.</u>	<u>WP Sequence No.</u>
Figure 6.	0091-8	
Figure 7.	0091-9	
Figure 8.	0091-10	
Figure 9.	0091-11	
Figure 10.	0091-12	
Figure 11.	0091-13	
Figure 12.	0091-14	
Figure 13.	0091-15	
Figure 14.	0091-16	
OPERATE VEHICLE IN EXTREME HEAT.....		WP 0092
Figure 1.	0092-2	
OPERATION IN EXTREME DUST.....		WP 0093
Figure 1.	0093-1	
Figure 2.	0093-2	
Figure 3.	0093-3	
OPERATE VEHICLE IN SAND OR MUD.....		WP 0094
Figure 1.	0094-2	
Figure 2.	0094-4	
OPERATE VEHICLE IN DESERT ENVIRONMENT.....		WP 0095
OPERATE VEHICLE IN COLD ENVIRONMENT (32°F [0°C] to -25°F [-32°C]).....		WP 0096
Figure 1.	0096-2	

TABLE OF CONTENTS - Continued

	<u>WP Sequence No.</u>
	<u>Page No.</u>
OPERATION IN EXTREME COLD ENVIRONMENT.....	WP 0097
Figure 1.	0097-3
OPERATE VEHICLE IN FOREST OR ROCKY TERRAIN.....	WP 0098
OPERATE VEHICLE IN SALTWATER AREAS.....	WP 0099
SET UP/SECURE HIGHWAY EMERGENCY MARKER KIT.....	WP 0100
Figure 1.	0100-1
Figure 2.	0100-2
Figure 3.	0100-2
Figure 4.	0100-2
Figure 5.	0100-3
Figure 6.	0100-3
Figure 7.	0100-4
Figure 8.	0100-4
Figure 9.	0100-5
Figure 10.	0100-5
Figure 11.	0100-6
MANUALLY RELEASE SPRING BRAKES.....	WP 0101
Figure 1.	0101-1
Figure 2.	0101-2
Figure 3.	0101-3
Figure 4.	0101-3
SLAVE START VEHICLE.....	WP 0102

TABLE OF CONTENTS - Continued

	<u>WP Sequence No.</u>
	<u>Page No.</u>
Figure 1.	0102-2
Figure 2.	0102-3
Figure 3.	0102-3
Figure 4.	0102-4
Figure 5.	0102-5
Figure 6.	0102-5
Figure 7.	0102-7
Figure 8.	0102-7
Figure 9.	0102-8
PERFORM IMMEDIATE ACTION FOR LOSS OF HYDRAULIC SYSTEM.....	WP 0103
PERFORM EMERGENCY HYDRAULIC OPERATION WHEN GROVE CRANE ELECTRICAL POWER FAILS	WP 0104
Figure 1.	0104-2
LIMP HOME/TRANSMISSION FAULT.....	WP 0105
Figure 1.	0105-2
STOWAGE AND SIGN GUIDE.....	WP 0106
Table 1. Inside Driver Side Door.....	0106-1
Table 2. Front Exterior.....	0106-3
Table 3. M977A2 Cargo Cabin.....	0106-4
Table 4. M977A2 Cargo Driver Side Exterior.....	0106-5
Table 5. M977A2 Cargo Passenger Side Exterior.....	0106-6
Table 6. M977A2 Cargo Rear Exterior.....	0106-7

TABLE OF CONTENTS - Continued

	<u>WP Sequence No.</u>
	<u>Page No.</u>
Table 7. M977A2 Miscellaneous Decals/Placards/ Plates/Stencils.....	0106-8
 Chapter 3 - Troubleshooting Procedures	
BUZZER SOUNDS AND AIR INDICATOR IS LIT.....	WP 0107
Figure 1.	0107-2
Figure 2.	0107-3
Figure 3.	0107-5
Figure 4.	0107-7
Figure 5.	0107-9
Figure 6.	0107-11
WINDSHIELD WASHER WILL NOT OPERATE.....	WP 0108
Figure 1.	0108-2
Figure 2.	0108-4
Figure 3.	0108-5
Figure 4.	0108-6
Figure 5.	0108-7
Figure 6.	0108-8
AIR SYSTEM LOSES PRESSURE DURING OPERATION.....	WP 0109
Figure 1.	0109-2
Figure 2.	0109-3
Figure 3.	0109-5
Figure 4.	0109-7

TABLE OF CONTENTS - Continued

	<u>WP Sequence No.</u>
	<u>Page No.</u>
TRAILER BRAKE DOES NOT APPLY WHEN SERVICE BRAKE TREADLE OR PARKING BRAKE IS USED.....	WP 0110
Figure 1.	0110-2
Figure 2.	0110-3
AIR HORN WILL NOT OPERATE.....	WP 0111
Figure 1.	0111-2
Figure 2.	0111-3
Figure 3.	0111-4
ARCTIC ENGINE HEATER FAILS TO OPERATE.....	WP 0112
Figure 1.	0112-2
Figure 2.	0112-4
Figure 3.	0112-6
ONE OR MORE LIGHTING CIRCUITS NOT OPERATING.....	WP 0113
Figure 1.	0113-1
Figure 2.	0113-3
FAILS TO CRANK WHEN ENGINE START SWITCH IS TURNED TO START POSITION.....	WP 0114
Figure 1.	0114-2
Figure 2.	0114-3
CRANKS BUT FAILS TO START.....	WP 0115
Figure 1.	0115-2
Figure 2.	0115-4
Figure 3.	0115-5

TABLE OF CONTENTS - Continued

	<u>Page No.</u>	<u>WP Sequence No.</u>
Figure 4.	0115-7	
STARTS OR RUNS ROUGHLY AFTER PROPER WARM-UP, DOES NOT MAKE FULL POWER, OR MAKES EXCESSIVE EXHAUST SMOKE.....		WP 0116
Figure 1.	0116-2	
Figure 2.	0116-4	
Figure 3.	0116-6	
ENGINE OVERHEATS.....		WP 0117
Figure 1.	0117-2	
Figure 2.	0117-4	
LOW OIL PRESSURE GAUGE INDICATION.....		WP 0118
Figure 1.	0118-2	
EXCESSIVE OIL CONSUMPTION.....		WP 0119
Figure 1.	0119-2	
HYDRAULIC SYSTEM OPERATES TOO SLOW, TOO FAST, WITH JERKY MOVEMENTS; OR ONE OR MORE HYDRAULICS CIRCUITS WILL NOT OPERATE.....		WP 0120
Figure 1.	0120-2	
Figure 2.	0120-3	
BOOM OPERATION ABNORMAL WHEN TELESCOPING IN OR OUT.....		WP 0121
Figure 1.	0121-2	
Figure 2.	0121-2	
Figure 3.	0121-3	
Figure 4.	0121-4	

TABLE OF CONTENTS - Continued

	<u>WP Sequence No.</u>	
	<u>Page No.</u>	
Figure 5.	0121-5	
BOOM RAISES OR LOWERS SLOWLY.....		WP 0122
Figure 1.	0122-2	
Figure 2.	0122-4	
BOOM WILL NOT RAISE OR LOWER.....		WP 0123
Figure 1.	0123-2	
BOOM WILL NOT TELESCOPE IN OR OUT.....		WP 0124
Figure 1.	0124-2	
CRANE CONTROLS STICKING IN ENGAGED POSITION.....		WP 0125
Figure 1.	0125-2	
Figure 2.	0125-4	
Figure 3.	0125-6	
Figure 4.	0125-7	
Figure 5.	0125-8	
CRANE WILL NOT OPERATE, OR OPERATES ABNORMALLY.....		WP 0126
Figure 1.	0126-2	
Figure 2.	0126-3	
Figure 3.	0126-4	
HOIST OPERATION SLOW OR ABNORMAL WHEN LIFTING OR LOWERING LOAD.....		WP 0127
Figure 1.	0127-2	
Figure 2.	0127-3	

TABLE OF CONTENTS - Continued

	<u>Page No.</u>	<u>WP Sequence No.</u>
Figure 3.	0127-4	
Figure 4.	0127-5	
Figure 5.	0127-6	
HOIST WILL NOT LIFT LOAD.....		WP 0128
Figure 1.	0128-2	
Figure 2.	0128-3	
MAST RAISES OR LOWERS ABNORMALLY.....		WP 0129
Figure 1.	0129-2	
Figure 2.	0129-4	
MAST RAISES OR LOWERS SLOWLY.....		WP 0130
Figure 1.	0130-2	
Figure 2.	0130-4	
OUTRIGGER OPERATION SLOW OR ABNORMAL.....		WP 0131
Figure 1.	0131-2	
Figure 2.	0131-3	
Figure 3.	0131-5	
Figure 4.	0131-6	
Figure 5.	0131-6	
SWING OPERATION ABNORMAL IN BOTH DIRECTIONS.....		WP 0132
Figure 1.	0132-2	
Figure 2.	0132-3	
Figure 3.	0132-4	

TABLE OF CONTENTS - Continued

	<u>Page No.</u>	<u>WP Sequence No.</u>
Figure 4.	0132-5	
Figure 5.	0132-6	
SWING OPERATION ABNORMAL IN ONLY ONE DIRECTION.....		WP 0133
Figure 1.	0133-2	
Figure 2.	0133-3	
Figure 3.	0133-4	
SELF-RECOVERY WINCH DOES NOT WORK.....		WP 0134
Figure 1.	0134-2	
Figure 2.	0134-3	
UNUSUALLY NOISY WHEN OPERATING.....		WP 0135
Figure 1.	0135-1	
Figure 2.	0135-2	
VEHICLE IS HARD TO STEER, SHIMMIES, WANDERS, OR PULLS TO ONE SIDE.....		WP 0136
Figure 1.	0136-2	
Figure 2.	0136-3	
VEHICLE STEERING SLOW TO RESPOND OR INTERMITTENT.....		WP 0137
Figure 1.	0137-2	
Figure 2.	0137-4	
UNUSUALLY NOISY WHEN OPERATING.....		WP 0138
Figure 1.	0138-1	
SLOW OR DIFFICULT ENGAGEMENT.....		WP 0139

TABLE OF CONTENTS - Continued

	<u>Page No.</u>	<u>WP Sequence No.</u>
Figure 1.	0139-1	
TRANSFER CASE SHIFT LEVER WILL NOT SHIFT.....		WP 0140
Figure 1.	0140-2	
Figure 2.	0140-3	
Figure 3.	0140-4	
Figure 4.	0140-5	
TRANS TEMP GAUGE INDICATES OVERHEATING DURING NORMAL OPERATION.....		WP 0141
Figure 1.	0141-2	
Figure 2.	0141-3	
WHEEL WOBBLES.....		WP 0142
Figure 1.	0142-2	
Figure 2.	0142-3	
TIRES WORN UNEVENLY OR EXCESSIVELY.....		WP 0143
Figure 1.	0143-2	
Chapter 4 - Preventive Maintenance Checks and Services (PMCS)		
INTRODUCTION - PREVENTIVE MAINTENANCE		WP 0144
Figure 1.	0144-3	
BEFORE - PREVENTIVE MAINTENANCE.....		WP 0145
Table 1. PMCS - BEFORE.....	0145-1	
Figure 1.	0145-5	
Figure 2.	0145-7	

TABLE OF CONTENTS - Continued

	<u>Page No.</u>	<u>WP Sequence No.</u>
Figure 3.	0145-8	
Figure 4.	0145-9	
Figure 5.	0145-10	
Figure 6.	0145-11	
Figure 7.	0145-15	
Figure 8.	0145-18	
Figure 9.	0145-20	
Figure 10.	0145-21	
Figure 11.	0145-23	
Figure 12.	0145-26	
Figure 13.	0145-29	
Figure 14.	0145-31	
Figure 15.	0145-34	
Figure 16.	0145-35	
Figure 17.	0145-37	
DURING - PREVENTIVE MAINTENANCE.....		WP 0146
Table 1. PMCS - DURING.....	0146-1	
Figure 1.	0146-2	
AFTER - PREVENTIVE MAINTENANCE		WP 0147
Table 1. PMCS - AFTER.....	0147-1	
Figure 1.	0147-5	
Figure 2.	0147-8	

TABLE OF CONTENTS - Continued

	<u>WP Sequence No.</u>
	<u>Page No.</u>
Figure 3.	0147-10
Figure 4.	0147-12
Figure 5.	0147-13
Figure 6.	0147-14
Figure 7.	0147-15
Figure 8.	0147-17
Figure 9.	0147-18
Figure 10.	0147-20
Figure 11.	0147-21
Figure 12.	0147-24
Figure 13.	0147-26
Figure 14.	0147-31
Figure 15.	0147-32
Figure 16.	0147-33
Figure 17.	0147-34
Figure 18.	0147-36
Figure 19.	0147-39
WEEKLY - PREVENTIVE MAINTENANCE.....	WP 0148
Table 1. PMCS - WEEKLY.....	0148-1
Figure 1.	0148-4
Figure 2.	0148-6
Figure 3.	0148-7

TABLE OF CONTENTS - Continued

	<u>WP Sequence No.</u>
	<u>Page No.</u>
Figure 4.	0148-9
Figure 5.	0148-10
Figure 6.	0148-12
Figure 7.	0148-13
Figure 8.	0148-14
Figure 9.	0148-15
Figure 10.	0148-16
Figure 11.	0148-17
Figure 12.	0148-19
Figure 13.	0148-20
Figure 14.	0148-21
Figure 15.	0148-23
Figure 16.	0148-24
Figure 17.	0148-25
Figure 18.	0148-26
Figure 19.	0148-28
Figure 20.	0148-30
Figure 21.	0148-31
Figure 22.	0148-34
Figure 23.	0148-36
Figure 24.	0148-41
Figure 25.	0148-42

TABLE OF CONTENTS - Continued

	<u>WP Sequence No.</u>
	<u>Page No.</u>
Figure 26.	0148-43
Figure 27.	0148-44
Figure 28.	0148-46
Figure 29.	0148-49
SEMIANNUAL - PREVENTIVE MAINTENANCE.....	WP 0149
Table 1. PMCS- SEMIANNUAL.....	0149-1
Figure 1.	0149-3
Figure 2.	0149-6
Figure 3.	0149-8
Figure 4.	0149-10
Figure 5.	0149-11
Figure 6.	0149-12
Figure 7.	0149-13
Figure 8.	0149-14
Figure 9.	0149-15
Figure 10.	0149-16
Figure 11.	0149-17
Figure 12.	0149-18
Figure 13.	0149-19
Figure 14.	0149-20
Figure 15.	0149-21
Figure 16.	0149-22

TABLE OF CONTENTS - Continued

	<u>WP Sequence No.</u>
	<u>Page No.</u>
Figure 17.	0149-24
Figure 18.	0149-25
Figure 19.	0149-26
Figure 20.	0149-27
MONTHLY - PREVENTIVE MAINTENANCE.....	WP 0150
Table 1. PMCS - MONTHLY.....	0150-1
Figure 1.	0150-4
Figure 2.	0150-5
Figure 3.	0150-6
Figure 4.	0150-7
Figure 5.	0150-8
Figure 6.	0150-9
Figure 7.	0150-11
Figure 8.	0150-13
Figure 9.	0150-14
 Chapter 5 - Maintenance Instructions	
LUBRICATION INSTRUCTIONS.....	WP 0151
Table 1. Engine Lubrication.....	0151-2
Table 2. Transmission and Transfer Case Lubrication.....	0151-3
Table 3. Axle Lubrication.....	0151-4
Table 4. Hydraulic Reservoir Servicing.....	0151-7
Table 5. Radiator Servicing.....	0151-7

TABLE OF CONTENTS - Continued

	<u>WP Sequence No.</u>
	<u>Page No.</u>
Table 6. Self-Recovery Winch Lubrication.....	0151-9
Table 7. Material Handling Crane Lubrication.....	0151-10
Table 8. Oil Can Point Lubrication.....	0151-11
Table 9. Miscellaneous Lubrication Points.....	0151-12
Table 10. Vehicle Cleaning.....	0151-13
CLOSE/OPEN HEATER VALVES.....	WP 0152
Figure 1.	0152-2
Figure 2.	0152-3
PRE/POST TOWING PROCEDURE (FRONT LIFT ONLY).....	WP 0153
Figure 1.	0153-2
Figure 2.	0153-3
Figure 3.	0153-4
Figure 4.	0153-5
CLEAN VEHICLE.....	WP 0154
Figure 1.	0154-1
Figure 2.	0154-2
CHANGE WHEEL AND TIRE ASSEMBLY.....	WP 0155
Figure 1.	0155-2
Figure 2.	0155-3
Figure 3.	0155-4
Figure 4.	0155-4
Figure 5.	0155-5

TABLE OF CONTENTS - Continued

	<u>Page No.</u>	<u>WP Sequence No.</u>
Figure 6.	0155-5	
Figure 7.	0155-6	
Figure 8.	0155-7	
Figure 9.	0155-8	
Figure 10.	0155-8	
Figure 11.	0155-9	
Figure 12.	0155-10	
Figure 13.	0155-11	
Figure 14.	0155-12	
Figure 15.	0155-13	
Figure 16.	0155-13	
Figure 17.	0155-14	
Figure 18.	0155-15	
Figure 19.	0155-16	
Figure 20.	0155-17	
Figure 21.	0155-18	
Figure 22.	0155-19	
CLEAN FUEL TANK STRAINER.....		WP 0156
Figure 1.	0156-1	
Figure 2.	0156-2	
SERVICE AIR CLEANER ELEMENT.....		WP 0157
Figure 1.	0157-1	

TABLE OF CONTENTS - Continued

	<u>Page No.</u>	<u>WP Sequence No.</u>
Figure 2.	0157-2	
Figure 3.	0157-3	
Figure 4.	0157-4	
Figure 5.	0157-5	
Figure 6.	0157-5	
Figure 7.	0157-6	
SERVICE TIRES.....		WP 0158
Figure 1.	0158-2	
Figure 2.	0158-3	
Figure 3.	0158-4	
Figure 4.	0158-5	
Figure 5.	0158-7	
OPEN/CLOSE BATTERY BOX.....		WP 0159
Figure 1.	0159-3	
Figure 2.	0159-5	
OPEN/CLOSE ENGINE COVERS AND ENGINE SIDE PANEL REMOVAL/INSTALLATION.....		WP 0160
Figure 1.	0160-1	
Figure 2.	0160-2	
Figure 3.	0160-3	
Figure 4.	0160-3	

TABLE OF CONTENTS - Continued

	<u>WP Sequence No.</u>
	<u>Page No.</u>
Chapter 6 - Supporting Information	
REFERENCES.....	WP 0161
COMPONENTS OF END ITEM AND BASIC ISSUE ITEMS LISTS.....	WP 0162
Table 1. List of Usable On Codes.....	0162-2
Table 2. Components of End Item.....	0162-2
Table 3. Basic Issue Items.....	0162-3
ADDITIONAL AUTHORIZATION LIST (AAL).....	WP 0163
Table 1. List of Usable On Codes.....	0163-1
Table 2. Additional Authorization List.....	0163-2
EXPENDABLE AND DURABLE ITEMS LIST.....	WP 0164
Table 1. Expendable and Durable Items List.....	0164-1

HOW TO USE THIS MANUAL

USABLE ON CODE (UOC) INFORMATION

Usable On Code (UOC) - the user should be aware that the M977A2 Cargo HEMTT series vehicle (with self-recovery winch installed) UOC is "H51". Dependent on the format used for printing this manual, the user may or may not see instructions printed in this manual stating what information is applicable to which model HEMTT series vehicle by UOC.

USABLE ON CODE (UOC) INFORMATION

Usable On Code (UOC) - the user should be aware that the M977A2 Cargo HEMTT series vehicle (without self-recovery winch installed) UOC is "H50". Dependent on the format used for printing this manual, the user may or may not see instructions printed in this manual stating what information is applicable to which model HEMTT series vehicle by UOC.

REMANUFACTURED VEHICLES

For the purposes of this manual, remanufactured A2R1 HEMTT series vehicle (see data plate on inside of driver side door) are considered HEMTT series vehicles and the user shall utilize any and all data applicable to the A2 HEMTT series vehicle.

WARNINGS, CAUTIONS, AND NOTES

Read all WARNINGS, CAUTIONS, AND NOTES before performing any procedure.

Warnings, cautions, notes, subject headings, and other essential information are printed in **BOLD** type, making them easier for the user to see.

GENERAL INFORMATION

This manual is designed to help operate and maintain the Heavy Expanded Mobility Tactical Truck (HEMTT). Listed below are some features included in this manual to help locate and use the required information:

- Chapter 1 of this manual includes HEMTT series vehicle general information, theory of operation, differences between models, etc.
- Chapter 2 of this manual provides operating procedures and operator Preventive Maintenance Checks and Services (PMCS) for both the HEMTT series vehicle, and its accompanying operating systems.
- Chapter 3 of this manual provides operator troubleshooting procedures for both the HEMTT series vehicle, and its accompanying operating systems.

In addition to text, there are illustrations showing:

1. Components, controls, and indicators.

GENERAL INFORMATION - Continued

2. How to take a component off, and put it back on.
3. Cleaning and inspection criteria are also listed when necessary.

CHAPTER 1

GENERAL
INFORMATION,
EQUIPMENT
DESCRIPTION AND
THEORY OF
OPERATION

OPERATOR MAINTENANCE INTRODUCTION

SCOPE

This manual is used for operation and operator-performed maintenance of HEMTT series vehicles which consist of a number of different models all built on similar chassis, but specially equipped to perform different missions.

Table 1. Overview.

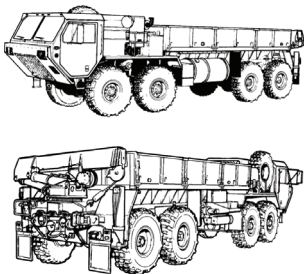
M977A2 CARGO	DESCRIPTION
 <p style="text-align: center;"><i>Figure 1.</i></p>	<p>Cargo vehicle with 59,500 lbs (27 000 kg) GVWR and 100,000 lbs (45 400 kg) GCWR. Vehicle has an 18 ft. (5.5 m) cargo body and is equipped with a material handling crane which has a maximum load capacity of 2500 lbs (1 135 kg) at 19 ft. (5.8 m) boom radius.</p>

MAINTENANCE FORMS AND RECORDS

Department of the Army forms and procedures used for equipment maintenance will be those prescribed by DA PAM 750-8 The Army Maintenance Management System (TAMMS) Users Manual. (WP 0161)

EQUIPMENT IMPROVEMENT REPORT AND MAINTENANCE DIGEST (EIR MD) AND QUALITY DEFICIENCY REPORTING (QDR).

The quarterly TB 43-0001-62 (series) Equipment Improvement Report and Maintenance Digest (WP 0161) contains valuable field information on equipment covered in this manual. Information in the TB 43-0001-62 (series) Equipment Improvement Report and Maintenance Digest (WP 0161) is compiled from some of the Equipment Improvement Reports (EIR) that have been prepared on vehicles covered in this manual. Many of these articles result from comments, suggestions, and improvement recommendations that were submitted to the EIR program. TB 43-0001-62 (series) Equipment Improvement Report and

EQUIPMENT IMPROVEMENT REPORT AND MAINTENANCE DIGEST (EIR MD) AND QUALITY DEFICIENCY REPORTING (QDR). - Continued

Maintenance Digest (WP 0161) contains information on equipment improvements, minor alterations, proposed Modification Work Orders (MWOs), warranties (if applicable), actions taken on some of the DA Form 2028's (WP 0161) (Recommended Changes to Publications), and advance information on proposed changes that may affect this manual. Refer to the TB 43-0001-62 (series) Equipment Improvement Report and Maintenance Digest (WP 0161) periodically for the most current and authoritative information on the equipment. The information will help to do a better job and will advise of the latest changes to this manual. Also refer to DA PAM 25-30, (WP 0161) Consolidated Index of Army Publications and Blank Forms at <http://www.army.mil/usapa/2530.html>, and reference section (WP 0161) of this manual. If you have a change recommendation to this manual, submit a DA Form 2028's (WP 0161) (Recommended Changes to Publications) via e-mail to: ROCK-TACOM-TECH-PUBS@conus.army.mil.

You can help improve this publication. If you find any mistakes or if you know of a way to improve the procedures, please let us know. Submit your DA Form 2028 (WP 0161) (Recommended Changes to Equipment Technical Publications) through the Internet, on the Army Electronic Product Support (AEPS) website. The Internet address is <https://aeps.ria.army.mil>. The DA Form 2028 (WP 0161) is located under the Public Applications section in the AEPS Public Home Page. Fill out the form and click on SUBMIT. Using this form on the AEPS will enable us to respond quicker to your comments and better manage the DA Form 2028 program. You may also mail, fax or e-mail your letter or DA Form 2028 (WP 0161) direct to: TACOM Life Cycle Management Command, ATTN: AMSTA-LC-LMPP / TECH PUBS, TACOM-RI, 1 Rock Island Arsenal, Rock Island, IL 61299-7630. The e-mail address is ROCK-TACOM-TECH-PUBS@conus.army.mil. The fax number is DSN 793-0726 or Commercial (309) 782-0726.

HAND RECEIPT (HR) INFORMATION

The is a companion document to this manual which consists of preprinted hand receipts (DA Form 2062) (WP 0161) that list end item related equipment (COEI, BII, (WP 0162) and AAL (WP 0163)) which must be accounted for. As an aid to property accountability, additional Hand Receipt (-HR) Manuals may be requisitioned from the following source in accordance with procedures in DA PAM 25-30, (WP 0161) Consolidated Index of Army Publications and Blank Forms; Commander US Army Distribution Operation Facility, 1655 Woodson Road, St Louis, MO 63114-6181.

CORROSION PREVENTION AND CONTROL

Corrosion prevention and control (CPC) of Army material is a continuing concern. It is important that any corrosion problems be reported so they can be corrected and improvements can be made to prevent problems in the future. While corrosion is typically associated with the rusting of metals, it can also include deterioration of other materials, such as rubber and plastic. Unusual cracking, softening, swelling, or breaking of these materials may be a corrosion problem.

CORROSION PREVENTION AND CONTROL - Continued

If a corrosion problem is identified, it can be reported using SF 368 (WP 0161). The use of key words, such as "corrosion", "rust", "deterioration", and "cracking" will ensure that the information is identified as a CPC problem.

DESTRUCTION OF ARMY MATERIAL TO PREVENT ENEMY USE

Procedures for the destruction of Army materiel to prevent enemy use are contained in TM 750-244-6 (WP 0161).

PREPARATION FOR STORAGE OR SHIPMENT

See information on preparing the HEMTT series vehicle for storage or shipment.

WARRANTY INFORMATION

The HEMTT series vehicles are warranted by Oshkosh Truck Corporation for 12 months or 12,000 miles (19 308 km), whichever comes first. The warranty starts on the date found in block 23 of DA Form 2408-9 (WP 0161) in the vehicle logbook. Report all defects in material or workmanship to the supervisor, who will take appropriate action through the field level maintenance shop.

NOMENCLATURE CROSS-REFERENCE LIST

Table 2. Common Nomenclature.

COMMON NAME	OFFICIAL NOMENCLATURE
Brake Pedal	Service Brake Pedal
Cable/Hoist Cable	Wire Rope
Cold Start System	Ether Quick-Start System
Electrical Control Box	Junction Box
Engine Coolant	Antifreeze, Ethylene Glycol Mixture
Glad Hand	Quick Disconnect Coupling
High Idle Switch	Engine Speed Control Switch
Jake Brake, Jacobs® Brake	Engine Retarder, Engine Brake

NOMENCLATURE CROSS-REFERENCE LIST - Continued*Table 2. Common Nomenclature. - Continued*

COMMON NAME	OFFICIAL NOMENCLATURE
Manual Controls	Directional Control Valves
O-Ring	Preformed Packing
Snap Ring	Retaining Ring

LIST OF ABBREVIATIONS*Table 3. Common Abbreviations.*

ABBREVIATION	OFFICIAL NOMENCLATURE
AAL	Additional Authorization List
AMDF	Army Master Data File
amp	Ampere
BAP	Bridge Adapter Pallet
bar	Barometric Pressure
BII	Basic Issue Items
BL	Bottom Load
BOI	Basis of Issue
C	Celsius
CAGEC	Commercial And Government Entity/Code
CARC	Chemical Agent Resistant Coating
CBR	Chemical, Biological, Radiological
CBT	Common Bridge Transporter

LIST OF ABBREVIATIONS - Continued

Table 3. Common Abbreviations. - Continued

ABBREVIATION	OFFICIAL NOMENCLATURE
CCA	Cold Cranking Amperes
CHU	Container Handling Unit
CID	Cubic Inch Displacement
CKT	Circuit
cm	Centimeter
COEI	Components of End Item
CPC	Corrosion Prevention Control
CROP	Container Roll-In/Out Platform
CTA	Common Table of Allowance
DA	Department of the Army
dia.	Diameter
DS	Direct Support
EIR	Equipment Improvement Recommendations
F	Fahrenheit
FHTV	Family of Heavy Tactical Vehicles
FLA	Front Lift Adapter
fl. oz.	Fluid Ounce
FR	Flatrack
FRS	Forward Repair System
ft.	Foot

LIST OF ABBREVIATIONS - Continued

Table 3. Common Abbreviations. - Continued

ABBREVIATION	OFFICIAL NOMENCLATURE
GAA	Grease, Automotive, and Artillery
gal	Gallon
GCWR	Gross Combination Weight Rating
GMT	Guided Missile Transport
GPFU	Gas Particulate Filter Unit
gpm	Gallons Per Minute
GS	General Support
GVWR	Gross Vehicle Weight Rating
HDI	Hexamethylene Diisocyanate
HEMTT	Heavy Expanded Mobility Tactical Truck
hp	Horsepower
HVAC	Heating, Ventilation, and Air Conditioning
IBC	Improved Boat Cradle
I.D.	Inside Diameter
in.	Inch
ISO	International Standards Organization
JTA	Joint Table of Allowances
kg	Kilogram
km	Kilometer
Kmh or km/h	Kilometer per Hour

LIST OF ABBREVIATIONS - Continued

Table 3. Common Abbreviations. - Continued

ABBREVIATION	OFFICIAL NOMENCLATURE
kPa	Kilopascals
kw	Kilowatt
L	Liter
lbs	Pound
lb-ft	Pound-Foot
lb-in	Pound-Inch
LCD	Liquid Crystal Display
LED	Light Emitting Diode
LH	Left-Hand
LHS	Load Handling System
M	Meter
MAC	Maintenance Allocation Chart
mi	Mile
ml	Milliliter
MLC	Military Load Class
mm	Millimeter
Mph	Miles Per Hour
MTOE	Modified Tables of Organization and Equipment
NBC	Nuclear, Biological, Chemical
NIIN	National Item Identification Number

LIST OF ABBREVIATIONS - Continued

Table 3. Common Abbreviations. - Continued

ABBREVIATION	OFFICIAL NOMENCLATURE
Nm	Newton Meter
NOC	Not Usable-On Code
NSN	National Stock Number
O.D.	Outside Diameter
OEA	Oil, Engine, Arctic
OE/HDO	Oil, Engine/Hydraulic Oil
O/R	Outrigger
OTC	Oshkosh Truck Corporation
Oz	Ounce
PLS	Palletized Load System
PMCS	Preventive Maintenance Checks and Services
psi	Pounds per Square Inch
pt.	Pint
PTO	Power Take-Off
qt.	Quart
Qty. Recm.	Quantity Recommended
Qty. Rqr.	Quantity Required
RCU	Remote Control Unit
RFI	Radio-Frequency Interference
RH	Right-Hand

LIST OF ABBREVIATIONS - Continued**Table 3. Common Abbreviations. - Continued**

ABBREVIATION	OFFICIAL NOMENCLATURE
rpm	Revolutions Per Minute
RPSTL	Repair Parts and Special Tools List
SAE	Society of Automotive Engineers
SMR	Source, Maintenance, and Recoverability
SRA	Specialized Repair Activity
SRW	Self-Recovery Winch
TAMMS	The Army Maintenance Management System
TDA	Tables of Distribution and Allowance
TM	Technical Manual
TMDE	Test, Measuring, and Diagnostic Equipment
TOE	Tables of Organization and Equipment
u/m	Unit of Measure
UOC	Usable-On Code
Vdc	Volts Direct Current
XHD	Extra Heavy-Duty

SAFETY, CARE, AND HANDLING

Significant hazards and safety recommendations are listed in the table below.

SAFETY, CARE, AND HANDLING - Continued**Table 4. Significant Hazard And Safety Recommendations.**

HAZARD	SAFETY RECOMMENDATION OR PRECAUTION	OPERATING CONDITION
Low air pressure for brakes.	Do not drive vehicle while low air pressure warning buzzer is sounding or red light is on.	Abnormal
Vehicle instability with crane use.	Ensure that outriggers are down on firm ground, side slope does not exceed 5 degrees, and crane is not overloaded.	Abnormal
Connecting towing devices.	Do not go between vehicles until vehicles are stopped and brakes are set.	Normal
Refueling vehicle.	Shut off engine and no smoking when filling tank.	Normal

NOTE

Category of hazards as to whether or not they may be expected under normal or abnormal operating conditions.

NOTE

- Material handling cranes have overload shutdown and/or tilt warning (unstable) systems. Always apply PARKING BRAKE control (WP 0045) prior to crane operation.
- When cranes are overloaded, the overload system will automatically shut off power to telescope boom out, raise boom, or hoist load higher. The overload system will also prevent lowering the boom. An overload condition can be corrected by lowering load to ground or other supporting surface. All crane functions will be restored in approximately six seconds.

NOTE

- The crane operating instruction plates are located on the heater compartment cover in the cab and at each of the fixed operating station.

SAFETY, CARE, AND HANDLING - Continued**Table 4. Significant Hazard And Safety Recommendations. - Continued**

HAZARD	SAFETY RECOMMENDATION OR PRECAUTION	OPERATING CONDITION
	<ul style="list-style-type: none"> <li data-bbox="278 402 1025 456">• The outrigger leg plates are located on each of the outrigger cylinders. 	

METRIC SYSTEM

The equipment described herein contains metric components and requires metric, common, and special tools. Therefore, metric units and English units will be used throughout this publication. An English-to-metric conversion table is included as the last page of this manual inside the back cover.

END OF WORK PACKAGE

OPERATOR MAINTENANCE WARRANTY PROGRAM

General

This work package provides implementation instructions for the warranty on the HEMTT. It contains instructions for obtaining services and/or supplies covered under warranty. This work package also describes methods of processing warranty claims. For additional warranty information on the HEMTT or any U.S. Army Tank-Automotive and Armaments Command (TACOM) equipment, contact your local Warranty Control Office/Officer (WARCO) or TACOM Logistics Assistance Representative (LAR). If your WARCO or TACOM LAR is not available or if additional information is required, contact TACOM.

Explanation of Terms

Abuse

The improper use, maintenance, repair or handling of warranted items that may cause the warranty of those items to become void (for example, not following service intervals, using the vehicle for other than what is intended).

Acceptance

The execution of the acceptance block and signing of DD Form 250 (WP 0161), by the authorized Government representative, unless end items are placed in storage in which case acceptance shall mean date of shipment from storage facility as reflected on DD Form 1149 (WP 0161) or DD Form 1348-1. (WP 0161)

Acceptance Date

The date an item of equipment is accepted into the Army's inventory by the execution of the acceptance block and signing of a DD Form 250 (WP 0161) or approved acceptance document, by an authorized representative of the Government.

Contractor

The supplier of equipment who enters into an agreement directly with the Government to furnish supplies.

Correction

The elimination of a defect.

Explanation of Terms - Continued

Defect

Any condition or characteristic in any supplies furnished by the contractor that does not otherwise function or threatens not to function as intended.

Failure

A part, component, or end item that fails to perform its intended use.

Manufacturer's Recall

Safety Recall An item is recalled to repair or replace a defective part or assembly which may affect safety.

Service Recall An item is recalled to repair or replace a defective part(s) or assembly which does not affect the safe use of this item.

Owning Unit

The Army Unit authorized to operate, maintain, and use the equipment.

Reimbursement

A written provision in this warranty in which the Using/Support Unit may make the necessary repairs, with or without prior approval from the contractor, and the Government will be reimbursed for the repair parts and labor costs.

Repair

A maintenance action required to restore an item to serviceable condition without affecting the warranty.

Supplies

The end item and all assemblies/parts furnished by the contractor.

Supporting Repair Facility

The repair activity authorized to accomplish warrantable repairs at the appropriate level of maintenance identified in the Maintenance Allocation Chart.

WARCO

Serves as the intermediary between the troops owning the equipment and the local dealer, contractor or manufacturer. All warranty claim actions will be processed through the WARCO.

Explanation of Terms - Continued

Warranty

A written agreement between a contractor and the Government which outlines the rights and obligations of both parties for defective supplies.

Warranty Claim

Action started by the equipment user for authorized warranty repair reimbursement.

Warranty Expiration Date

The date the warranty is no longer valid. This date will be 13 months from the contractor shipment date. This warranty period covers the basic 12 months plus on additional month for shipping time.

Warranty Period

Time during which the warranty is in effect; normally measured as the maximum number of years, months, days, miles, or hours used.

Warranty Start Date

The day shipment is put into effect (Contractor Shipment Date).

Coverage-Specific

This work package applies to:

Table 1. Vehicle Information

Noun	Model	NSN	Cage
Truck, Cargo	M977A2 (without winch)	2320-01-493-3779	45152

NOTE

The item is manufactured by Oshkosh Truck Corporation (OTC), under contract #W56HZV-07-C-0248. Inquiries to OTC can be made by calling (920) 235-9151.

Coverage-Specific - Continued

Table 2. Vehicle Information

Noun	Model	NSN	Cage
Truck, Cargo	M977A2 (with winch)	2320-01-493-3774	45152
<p style="text-align: center;">NOTE</p> <p style="text-align: center;">The item is manufactured by Oshkosh Truck Corporation (OTC), under contract #W56HZV-07-C-0248. Inquiries to OTC can be made by calling (920) 235-9151.</p>			

The contractor warrants the supplies are free from defects in design, material, and workmanship for a period of thirteen (13) months from warranty start date.

If a Safety recall defect occurs during the vehicle warranty period, the contractor agrees to extend the terms of the warranty to the time required to make necessary safety defect corrections. Also, if the contractor or his supplier(s) provide a greater warranty for the supplies furnished, the contractor will provide the greater warranty to the Government.

If a defect/failure is caused by or falls within any of the following categories, it is not considered warrantable and a claim should not be initiated:

1. Misuse or negligence
2. Accidents
3. Improper operation
4. Improper storage
5. Improper transport
6. Improper or insufficient maintenance
7. Improper alterations or repairs
8. Defect/failure discovered or occurring after warranty expiration date.
9. Fair wear and tear items (brake shoes, pads, armatures, brushes, etc.).

In addition to the 13 month warranty, the vehicles will be warranted for a total service life of 10 years including extended periods in a corrosion hazard military environment. During this 10 year service life, there will be no damage caused by corrosion requiring repair or replacement of parts. No actions beyond normal washing or replacement of accident-damaged paint shall be necessary to maintain the corrosive protection in place.

This 13 month warranty is extended up to nine (9) months from date of acceptance if the vehicle is put into government storage before use. In this case, the warranty starts when

Coverage-Specific - Continued

the vehicle is either taken out of storage or until nine (9) months from the warranty start date shown on the warranty data plate, whichever occurs first. Refer to preparation for storage.

Contractor Responsibilities

When the owning unit has directed the contractor to correct the supplies, the contractor will furnish all material required to correct the defective supplies. Repairs and parts shall be initiated/provided within ten (10) working days after receipt of written claim notification. Furthermore, the contractor will provide a copy of the work order to owning unit upon completion of repair.

When the contractor receives written notification requiring contractor repair, they will have the option:

1. Correct the supplies in the field.
2. Return the vehicle or parts to the contractor's designated facility for correction.

When the contractor corrects the supplies, all labor involved shall be borne by the contractor. Additionally, the contractor shall arrange and bear all transportation costs of the supplies to its facility and return to user.

The contractor, within five (5) working days of receiving such notice, shall notify the warranty claimant by telephone as to the method of correction, date(s) work is to be performed and by whom.

Government Responsibilities

The Major Subordinate Command for the HEMTT is the U.S. Army Tank-Automotive and Armaments Command (TACOM), Warren, MI 48397-5000. TACOM is responsible for managing and implementing the warranty.

TACOM will:

Insure the contractor performs in accordance to the terms of the contract.

Equipment owning unit will:

1. Identify defects/failures and verify the defects/failures are warrantable.
2. Submit warranty claims, using DA Form 2407 (WP 0161) or DA Form 2407-1 (WP 0161) to your local Warranty Coordinator.
3. Tag and retain (IAW DA PAM 750-8 and this work package) (WP 0161) parts, pieces of parts and/or assemblies removed at the owning unit level and as a result of a warrantable defect/failure and/or correction.

Government Responsibilities - Continued

Supporting repair facility will:

1. Identify defects/failures as warrantable (if owning unit has not already identified them). Verify defects/failures are warrantable.
2. Review, process, and submit valid warranty claims to the local WARCO if the DA Form 2407 (WP 0161) is complete and correctly filled out.
3. Reject invalid warranty claims or request additional information for incomplete and incorrect claims.
4. Coordinate with the owning unit and decide which option for repair is desired to correct the warrantable defect/failure.
5. Depending on which repair option was chosen (Government or contract repair) provide labor/parts required to accomplish the warrantable repairs.
6. Tag and retain (IAW DA PAM 750-8 and this work package) (WP 0161) all parts, pieces, or parts and/or assemblies removed as a result of warrantable defect/failure and/or correction.

Local WARCO will:

1. Verify, review, process, and if valid and complete, submit claims (reimbursable and/or disputes) to the contractor.
2. Reject claims that are not valid, and send them back to the local Unit with a short explanation of why the claim is rejected.
3. Request additional information for incomplete claims.
4. Provide warranty claim acknowledgment closeout and/or parts/assemblies disposition instructions to the local Unit.
5. Insure the contractor performs in accordance to the terms of the contract.
6. Verify, administer and process warranty claims.
7. Act as a liaison between owning unit, the contractor, supporting repair facility and TACOM.
8. Notify the owning units of all warranty claim acknowledgments/close-outs, information and/or instructions received from TACOM or the contractor.
9. Act as a liaison between local dealers and the Army.
10. Enter all open and closed WCAs into the Army Electronics Product Support (AEPS), Electronic Deficiency Reporting System.
11. The information/data provided on the DA Form 2407 (WP 0161) are placed into the AEPS Deficiency Reporting System (DRS) at the installation WARCO office to facilitate MSC management and tracking of warranties.

Alterations/Modifications

Alterations/modifications shall not be applied unless authorized by TACOM.

Warranty Data Plate

All vehicles will have a warranty data plate. The contractor is required to mount his data plate within clear view of the operator.

Warranty Data Plate - Continued

When the vehicle is received, the owning unit should locate the warranty data plate and check the warranty start date with date shown on the applicable DD Form 250 (WP 0161) or DD Form 1149. (WP 0161) If these dates differ, disregard the data plate. The date shown on the DD Form 250 (WP 0161) or DD Form 1149. (WP 0161) is the date to be used as a warranty start date.

Claim Procedures

The procedures for reporting warranty claims are found in DA PAM 750-8 (WP 0161) and this work package. Responsibilities of the MACOM are found in AR 700-139. (WP 0161) All Warranty Claim Actions are processed on DA Form 2407 (WP 0161) and DA Form 2407-1. (WP 0161) It is very important to fill in the blocks on the forms as accurately as possible.

The contractor shall be notified in writing within 30 days, utilizing DA Form 2407 (WP 0161) by the local Warranty Control Office/Officer (WARCO) following the discovery of a defect in supplies which requires contractor repair and/or replacement parts. This shall constitute formal notification of a warranty claim, and initiate the time period for contractor responsibilities and action under the warranty. This notification shall include, but not be limited to furnishing of the equipment serial number, operating hours, part number or NSN of the defective part and circumstances surrounding the defect(s). At this time, the contractor will further be informed whether the owning unit has elected:

1. To correct the defect themselves.
2. To direct the contractor to correct the defect.

Upon completion of contractor repair, forward completed warranty claims (Information Only) electronically to AEPS (Army Electronic Product Support) <http://aeprs.ria.army.mil>.

The contractor shall reimburse the government for the cost of labor and/or replacement parts involved in the government correction of the defect. The government's Maintenance Allocation Chart (MAC) determines the times. Additionally, the cost of replacement parts obtained through the Government's supply channels will be determined by the amount identified in the contractor's current commercial dealer net price or Army Master Data File (AMDF) price, whichever is less. Furthermore, the owning unit may direct the contractor to provide the replacement parts that prove to be defective within the warranty period, without costs to the government, directly to their location or F.O.B., U.S. Port of Embarkation for OCONUS. The contractor shall furnish replacement parts within 10 working days after receipt of written claim notification. DO NOT submit warranty claims for reimbursement where repair labor costs and replacement parts costs combined do not exceed \$150.00 for any one failure.

Identification Of Failed Items. Failed warranty items shall be tagged/identified to prevent improper repair or use. Documents that describe the use of DA Form 2402 Maintenance Tag (WP 0161) and DA Form 2407 Maintenance Request (WP 0161) shall be referenced. Items requiring special handling, storage, or shipment during the processing of claims shall be identified.

Claim Procedures - Continued

Disposition. The repair activity shall retain defective supplies for thirty (30) days following receipt of acknowledgment of warranty claim from WARCO or contractor. If receipt of acknowledgment is not received, inquiries should be made to your local WARCO. If receipt of acknowledgment is received but no instructions are forthcoming within thirty (30) days of receipt, supplies may be disposed.

Invalid Warranty Claims. When supplies are inspected by the contractor and found to be non-warrantable due to abuse or improper maintenance, or the supplies are found to be serviceable, the repair activity submitting the claim will be required to make reimbursement for contractor services. All failed items returned for warranty claim action will be monitored by the WARCO. Additionally, regarding contractor repair, the local WARCO must stipulate at the time of request for services that either no non-warranty work be done or be prepared to pay for such work.

Reimbursement for Army Repair

In the event that the repair activity should receive any reimbursement from the contractor, the monies must be forwarded to the following address: Defense Accounting Office, DAOTACOM, ATTN: DFAS-IN/EM-BED, TACOM, Warren, Michigan 48397-5000.

Claim Denial/Disputes

All denials or disputes will be handled by TACOM.

Reporting

Reporting or recording action on a failed item shall be specified in DA PAM 750-8. (WP 0161) Contractor or repair activity unique forms shall not be used.

Storage/Shipment/Handling

Storage

See coverage-specific data above (last paragraph) and preparation for storage for further information.

Shipment

See contractor responsibilities data above (second paragraph), claim procedures (third paragraph), and preparation of equipment for transportation/shipment for further information.

Storage/Shipment/Handling - Continued**Handling**

See contractor responsibilities data above (second paragraph), claim procedures (third paragraph), and safety, care, and handling for further information.

END OF WORK PACKAGE

OPERATOR MAINTENANCE EQUIPMENT CHARACTERISTICS, CAPABILITIES, AND FEATURES

EQUIPMENT CHARACTERISTICS

The M977A2 cargo vehicle is used for ammunition resupply and other logistic missions.

EQUIPMENT CAPABILITIES

NOTE

Trailer/semitrailer may affect maximum fording depth. Refer to applicable trailer/semitrailer operator manual for further information on fording depth restrictions.

1. All models are capable of operating in temperatures from -25 to 120°F (-32 to 49°C) and to -50 to 120°F (-46 to 49°C) with arctic kit installed.
2. All models can ford water up to 48 in. (1 219 mm) deep for 5 minutes without damage or without requiring maintenance before operation can continue.
3. Normal operating range of all models is 300 miles (483 km), based upon 154 gallons (583 L) of fuel and 100,000 lbs (45 400 kg) GCWR, traveling over mixed terrain. Varying loads, prolonged idle, use of power takeoff (PTO), off-road driving, and climatic conditions affect operating range.
4. All models are provided with sufficient tiedown points located so vehicles can be restrained in all directions during air transport in C-130, C-5A, and C-17 type aircraft.
5. All models are also capable of being transported by highway, rail, and sea.

EQUIPMENT FEATURES

1. The DDEC IV is an electronically controlled, eight-cylinder, V-Type, 2-cycle, fuel injected, and turbocharged diesel engine.
2. Push-button automatic transmission with one reverse speed and five forward speeds.
3. Operator controlled 4-wheel/8-wheel drive and high and low range transfer case for positive traction in areas of unimproved road surfaces.
4. Power steering system consists of basic manual steering system with hydraulic boost. Mechanical linkage also provides operator control in event of hydraulic oil pressure loss.
5. Fuel system includes one fuel tank, fuel lines, fuel/water separator, fuel pump, secondary filter, fuel pipes, and fuel injectors.
6. Two front and two rear towing eyes.
7. Manual-release-type rear pintle hook, which will allow towing of a trailer.

EQUIPMENT FEATURES - Continued

8. Radio frequency interference suppression to permit voice radio communications during all phases of operation.

END OF WORK PACKAGE

**OPERATOR MAINTENANCE
LOCATION AND DESCRIPTION OF MAJOR COMPONENTS**

VEHICLE COMPONENT LOCATION

Table 1. HEMTT Series Vehicle Common Component Location.

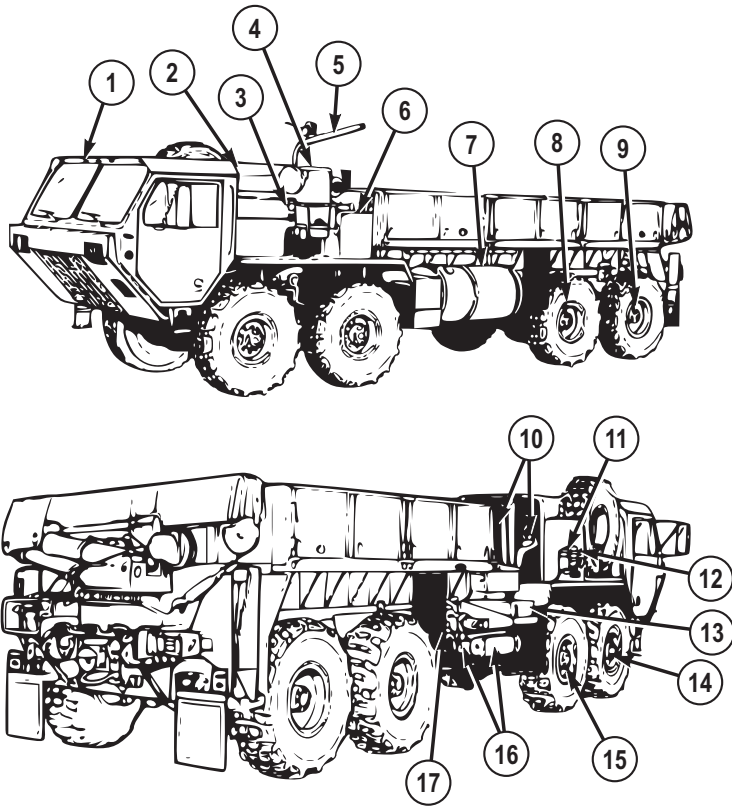

Figure 1.

- | | |
|---|---|
| 1 | Personnel Cab. Provides protection from weather for crew and vehicle controls, gauges, and indicators. |
|---|---|

VEHICLE COMPONENT LOCATION - Continued

Table 1. HEMTT Series Vehicle Common Component Location. - Continued

2	Engine Compartment. Engine supplies power to move vehicle and operate equipment and accessories.
3	Ether Canister. Contains ether for use as cold weather starting aid.
4	Air Cleaner. Filters out dust and debris from air entering air induction system.
5	Tire Davit (shown assembled). Used to raise and lower spare tire.
6	Hydraulic Reservoir. Stores, cools, and filters oil used in hydraulic and power steering systems.
7	Fuel Tank. Stores fuel used to operate engine. Receives excess fuel not used by engine fuel injection system.
8	No. 3 Driving Axle. Supports weight of vehicle, and transmits power to hubs to turn rear wheels.
9	No. 4 Driving Axle. Supports weight of vehicle, and transmits power to hubs to turn rear wheels.
10	Tire Davit (shown in stowed position). Used to raise and lower spare tire.
11	Air Dryer. Used to remove dirt and moisture from compressed air before air enters air reservoirs.
12	Fuel/Water Separator. Acts as primary fuel filter and removes any water from fuel before entering engine.
13	Battery Box. Houses and protects four storage batteries.
14	No. 1 Driving Axle. Controls direction of vehicle when in motion. When needed, transmits power to hubs to turn wheels.
15	No. 2 Driving Axle. Controls direction of vehicle when in motion. When needed, transmits power to hubs to turn wheels.
16	Air Reservoirs. Used to store air system air.
17	Self-Recovery Winch (not used on all vehicles). Used to help vehicle pull itself free of obstructions.

VEHICLE COMPONENT LOCATION - Continued

Table 2. M977A2/M985A2 Cargo Vehicle Specific Component Location.

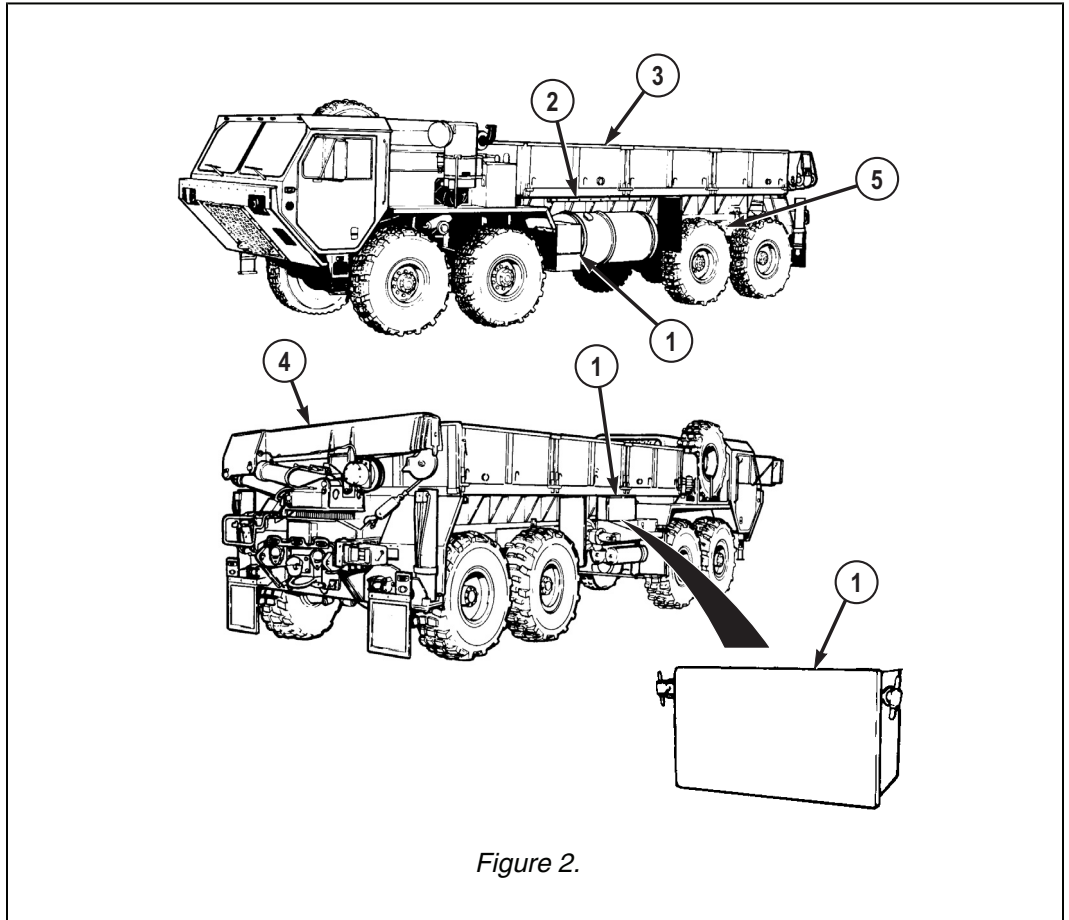

Figure 2.

1	Stowage Boxes. Used to stow COEI, BII, (WP 0162)AAL, (WP 0163) and other mission essential items.
2	Access Ladder. Used by crew to clean windows, check oil, or perform other tasks requiring access to parts of vehicle.
3	Cargo Body. Used to carry palletized ammunition. Tiedowns are provided to allow ammunition pallets to be tied down.
4	Material Handling Crane. Used to load and unload cargo.

VEHICLE COMPONENT LOCATION - Continued**Table 2. M977A2/M985A2 Cargo Vehicle Specific Component Location. - Continued**

5	Wheel Chock Stowage Box. Used to stow two wooden wheel chocks.
---	---

END OF WORK PACKAGE

**OPERATOR MAINTENANCE
DIFFERENCES BETWEEN MODELS**

Table 1. Differences Between HEMTT A2 Models.

Equipment	Model								
	M977 (Note 1)	M978 (Note 1)	M983 (Note 2)	M983 LET (Note 3)	M984 (Note 2)	M985 (Note 1)	M985 E1 (Note 2)	M1120 LHS (Note 1)	M1977 CBT (Note 1)
10 ft. (3.05 m) Equipment Body					•				
18 ft. (5.49 m) Cargo Body	•					•	•		
Cargo Cover Kit	•					•	•		
Heavy-Duty Winch				•	•				
Rear Beacon Lights (Note 4)					•				
Work Lights (Note 5)			•	•	•				•
MHC977 Grove Crane	•								
MHC985 Grove Crane						•			
MHC984					•				

Table 1. Differences Between HEMTT A2 Models. - Continued

Equipment	Model								
	M977 (Note 1)	M978 (Note 1)	M983 (Note 2)	M983 LET (Note 3)	M984 (Note 2)	M985 (Note 1)	M985 E1 (Note 2)	M1120 LHS (Note 1)	M1977 CBT (Note 1)
Grove Crane									
8108-2/2CD HIAB Crane (Note 6)							•		
Fifth Wheel			•	•					
3.5 inch (89 mm) Kingpin			•	•					
Semitrailer Spare Tire Carrier			•						
Load Handling System								•	•

Table 2. Notes.

Note:

1. Vehicle can be equipped in either of two configurations: with or without optional self-recovery winch.
2. Vehicle equipped with self-recovery winch.
3. Self-recovery winch not available for this model.
4. All HEMTT series vehicles are authorized to carry portable beacon light as an optional accessory.
5. All HEMTT series vehicles are authorized to carry portable work lamp as an optional accessory.
6. See data plate on base of crane loader body unit to determine model number.

END OF WORK PACKAGE

**OPERATOR MAINTENANCE
EQUIPMENT DATA**

EQUIPMENT DATA

Table 1. Vehicle Operation.

Operating Mode: On and off-road
Operating Temperature w/o Arctic Kit: -25 to 120°F (-32 to 49°C)
Operating Temperature w/Arctic Kit: -50 to 120°F (-46 to 49°C)

Table 2. M977A2 Cargo Vehicle Dimensions.

Width (overall): 96 in. (2 438 mm)
Height (overall): 112 in. (2 845 mm)
Height (reduced for shipping): 102 in. (2 591 mm)
Length Overall: 401 in. (10 185 mm)
Wheelbase: 210 in. (5 334 mm)
Turn Circle (curb to curb):
Ground Clearance: 24 in. (610 mm)
Center of Gravity: See shipping data plate on outside of driver side rear of cab or inside of driver side door.

Table 3. M977A2 Cargo Vehicle Weight.

Curb Weight: 38, 800 lbs (17 615 kg)
Gross Vehicle Weight Rating (GVWR): 59,500 lbs (27 013 kg)
Gross Combination Weight Rating (GCWR): 100,000 lbs (45 400 kg)

EQUIPMENT DATA - Continued

Table 4. M977A2 Cargo Vehicle Weight.

Curb Weight: 37,900 lbs (17 207 kg)
Gross Vehicle Weight Rating (GVWR): 59,500 lbs (27 013 kg)
Gross Combination Weight Rating (GCWR): 100,000 lbs (45 400 kg)

Table 5. M977A2 Cargo Vehicle Weight Distribution.

Front Tandem Axles-Curb: 21,300 lbs (9 670 kg)
Front Tandem Axles-Loaded: 30,000 lbs (13 620 kg)
Rear Tandem Axles-Curb: 17,500 lbs (7 945 kg)
Rear Tandem Axles-Loaded (maximum): 32,000 lbs (14 528 kg)

Table 6. M977A2 Cargo Vehicle Weight Distribution.

Front Tandem Axles-Curb: 20,900 lbs (9 489 kg)
Front Tandem Axles-Loaded: 30,000 lbs (13 620 kg)
Rear Tandem Axles-Curb: 17,000 lbs (7 718 kg)
Rear Tandem Axles-Loaded (maximum): 32,000 lbs (14 528 kg)

Table 7. Vehicle Performance.

Cruising Range at GCWR: 300 mi. (483 km)
Maximum Sustained Forward Speed (at 1696 rpm) - 5th Gear: 63 mph (101 km/h)
Maximum Sustained Forward Speed (at 2100 rpm) - 4th Gear: 60 mph (97 km/h)
Maximum Sustained Forward Speed (at 2100 rpm) - 3rd Gear: 39 mph (63 km/h)
Maximum Sustained Forward Speed (at 2100 rpm) - 2nd Gear: 27 mph (43 km/h)
Maximum Sustained Forward Speed (at 2100 rpm) - 1st Gear: 12.7 mph (20 km/h)

EQUIPMENT DATA - Continued

Table 7. Vehicle Performance. - Continued

Speed on 3% Grade at GCWR: 25 mph (40 km/h)
Speed on 3% Grade at GVWR: 40 mph (64 km/h)
Speed on 30% Grade at GCWR: 3 mph (5 km/h)
Speed on 30% Grade at GVWR: 5 mph (8 km/h)
Maximum Grade at GCWR: 30 percent
Maximum Grade at GVWR: 60 percent
Maximum Side Slope w/Adequate Traction Surface: 30 percent
Maximum Towed Speed (refer to FM 4-30.31): 15 mph (24 km/h)
Maximum Ford Depth: 48 in. (1 219 mm)
Approach Angle: 41 degrees
Departure Angle: 45 degrees
Limp Home Speed: 10 mph (16 km/h) for up to 30 miles (48 km)

Table 8. Fluid Capacities.

Refer to lubrication instructions in operator's PMCS (WP 0151) for vehicle fluid capacities.
--

Table 9. Engine.

Make: Detroit Diesel Corporation
Model: 8V92TA DDEC IV
Type: 2-Stroke, V-Type Diesel
Cylinders: 8
Bore: 4.84 in. (123 mm)

EQUIPMENT DATA - Continued

Table 9. Engine. - Continued

Stroke: 5 in. (127 mm)
Displacement: 736 cid (12 L)
Torque (at 2100 rpm): Model No. 80837K92: 1113 lb-ft (1509 Nm) at 1300 rpm
Maximum Brake Horsepower (at 2100 rpm): Model No. 80837K92: 445 BHP (332 kW)
Maximum Governed Engine Speed - Loaded: 2050 - 2150 rpm
Maximum Governed Engine Speed - No Load: 2225 - 2275 rpm
Oil Filter Type: Full flow, replaceable element
Oil Filter Quantity: 1

Table 10. Fuel System.

Type: Diesel Injection
Tank Quantity: 1
Air Cleaner Type: Dry element
Element Quantity: (1 primary, 1 secondary)

Table 11. Electrical System.

Voltage: 24
Alternator (amps): 130
RFI Suppression Ability: Yes
Number of Batteries: 4
Battery Voltage (each): 12 volts
Battery Connection: Series - parallel

EQUIPMENT DATA - Continued

Table 11. Electrical System. - Continued

Battery Capacity (at 20 hour rate): 900 amp
Battery Reserve Capacity (each, at 80°F/27°C): 180 minutes
Battery Cold Cranking Amps (each, at 80°F/27°C): 575 CCA
Battery Amp Hours (each, at 20 hour rate): 100 amp

Table 12. Cooling System.

Radiator Working Pressure: 7 psi (48 kPa)
--

Table 13. Transmission.

Make: Allison
Model: HD4560
Type: Automatic
Number of Forward Speeds: 5
Number of Reverse Speeds: 1
NOTE
The operator should be aware of which model transmission vehicle is equipped with. HEMTT A2 series vehicles may be equipped with either the Allison HD4560 (older) or Allison 4500SP (newer) automatic transmission. The differences between the transmissions are called out throughout this manual.
Make: Allison
Model: 4500 SP
Type: Automatic
Number of Forward Speeds: 5

EQUIPMENT DATA - Continued

Table 13. Transmission. - Continued

Number of Reverse Speeds: 1

Table 14. Transfer Case.

Make: Oshkosh

Model: 55000

Type: Air-operated front tandem disconnect

Ratios: 0.98:1 and 2.66:1

Table 15. Front Tandem Axles.

Front Tandem

Make: Oshkosh/Dana Heavy Axle

Differential Carrier Model Nos.: No. 1 axle: RS480, No. 2 axle: DS480-P
--

Maximum Steering Angle: 32 degrees

Table 16. Rear Tandem Axles.

Make: Dana Heavy Axle

Differential Carrier Model Nos.: No. 3 axle: DS480-P, No. 4 axle: RS480
--

Table 17. Brake System.

Actuation: Air

Number of Brake Chambers: 8

Pressure Range: 60 - 120 psi (414 - 827 kPa)

EQUIPMENT DATA - Continued**Table 18. Wheels.**

Type: Two-piece bolt together wheel
Quantity: 8
Spare Quantity: 1
Rim Size: 20 x 10
Stud Quantity Per Wheel: 10

Table 19. Tires.

Type: Radial without tube
Quantity: 8
Spare Quantity: 1
Tread Type: Radial traction, non-directional
Size: 16.00R x 20 in.
Load Range: M

Table 20. Steering System.

Type: Dual gear with integrated hydraulic power assist

Table 21. Towing Eyes.

Quantity: 4 (2 front, 2 rear)
Maximum Load Capacity Each: 60,000 lbs (27 240 kg)

Table 22. Pintle Hook.

Type: Manual Release
Maximum Load Capacity - Pulling: 30,000 lbs (13 620 kg) in off-road application

EQUIPMENT DATA - Continued

Table 22. Pintle Hook. - Continued

Maximum Load Capacity - Vertical: 1,700 lbs (771 kg)

Table 23. Cab.

Windshield: Tinted, two-piece, safety glass
--

Personnel Capacity: 2

Table 24. Self-Recovery Winch.

Make: DP Manufacturing

Model: 20K-HEMTT

Wire Rope Diameter: 9/16 in. (14.3 mm)

Wire Rope Length: 200 ft. (61 m)

Line Pull - 1st Layer (Five Wraps Minimum): 20,000 lbs (9 080 kg)
--

Line Pull - 2nd Layer: 18,173 lbs (8 251 kg)

Line Pull - 3rd Layer: 16,663 lbs (7 565 kg)

Line Pull - 4th Layer: 15,361 lbs (6 974 kg)

Line Pull - 5th Layer: 14,254 lbs (6 471 kg)

Table 25. Material Handling Crane.

Make: Grove

Model: MHC977

Maximum Capacity at Boom Length of 19 ft. (5.8 m): 2500 lbs (1 135 kg)

Table 26. Auxiliary Equipment.

Arctic Engine Heater Kit

EQUIPMENT DATA - Continued

Table 26. Auxiliary Equipment. - Continued

Chemical Alarm
Decontamination Unit
Gas Particulate Filter Unit
Machine Gun Ring
Radio Installation Kit
Rifle Mounting Kit
Note: Vehicle may or may not be equipped with any of these items depending on mission, climate, or other factors.

Table 27. M977A2 Cargo Vehicle Load Classification.

UNLOADED (TONS)	FULL LOAD (TONS)	WITH TRAILER LOADED (TONS)
16	28	N/A

TIRE PRESSURES

Table 28. Tire Pressures.

TIRE	HIGHWAY	CROSS-COUNTRY (DRY)	CROSS-COUNTRY (WET)	SANDY TERRAIN
Front Tire Pressure				
STANDARD (XZL) TIRE	60 psi (414 kPa)	35 psi (241 kPa)	20 psi (138 kPa)	30 psi (207 kPa)
SAND TIRE	60 psi (414 kPa)	NA	NA	25 psi (172 kPa)
Rear Tire Pressure				

TIRE PRESSURES - Continued*Table 28. Tire Pressures. - Continued*

TIRE	HIGHWAY	CROSS-COUNTRY (DRY)	CROSS-COUNTRY (WET)	SANDY TERRAIN
STANDARD (XZL) TIRE	70 psi (483 kPa)	40 psi (276 kPa)	30 psi (207 kPa)	35 psi (241 kPa)
SAND TIRE	70 psi (483 kPa)	NA	NA	30 psi (207 kPa)
Spare Tire Pressure				
STANDARD (XZL) TIRE	100 psi (690 kPa)	100 psi (690 kPa)	100 psi (690 kPa)	100 psi (690 kPa)
SAND TIRE	100 psi (690 kPa)	NA	NA	100 psi (690 kPa)

OPERATING SPEEDS*Table 29. Operating Speeds.*

	HIGHWAY	CROSS-COUNTRY (DRY)	CROSS-COUNTRY (WET)	SANDY TERRAIN
STANDARD (XZL) TIRE (maximum Speed)	55 mph (88 km/h)	40 mph (64 km/h)	20 mph (32 km/h)	20 mph (32 km/h)
SAND TIRE (maximum Speed)	55 mph (88 km/h)	NA	NA	20 mph (32 km/h)

END OF WORK PACKAGE

OPERATOR MAINTENANCE SELF-RECOVERY WINCH

SELF-RECOVERY WINCH

The self-recovery winch, when used, is mounted on the passenger side chassis frame rail between the second and third axles.

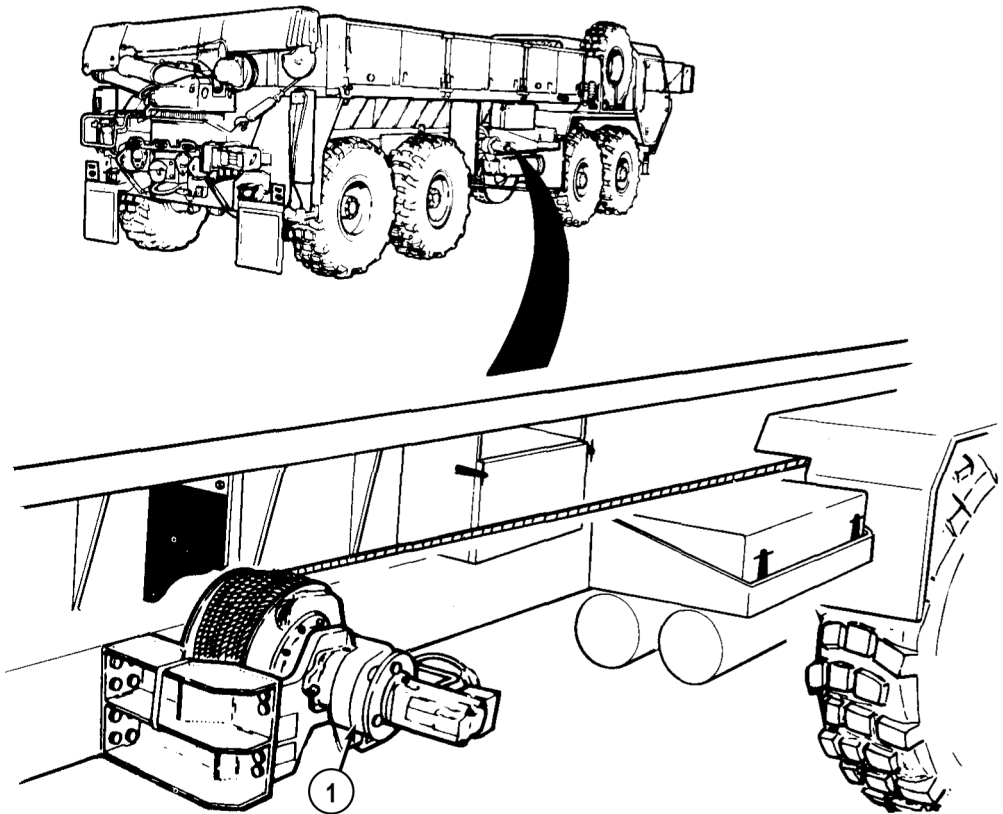

Figure 1.

The winch is powered by a reversible hydraulic motor which drives the winch drum through a planetary gearbox.

It is equipped with an automatic brake that is applied whenever the cab control lever is in the center position.

SELF-RECOVERY WINCH - Continued**NOTE**

The M984A wrecker equipped with a self-recovery winch does not employ an operator controlled, two-position hydraulic selector valve to activate the reversible winch motor.

All vehicles (except the M984A wrecker) equipped with a self-recovery winch (1) have an operator controlled, two-position hydraulic selector valve (WP 0025) to activate the reversible winch motor.

END OF WORK PACKAGE

**OPERATOR MAINTENANCE
ELECTRICAL SYSTEM**

ELECTRICAL SYSTEM**NOTE**

- Wiring harnesses are used to carry current to operate equipment and accessories.
- The electrical system is a 24 VDC system.

Four 12 VDC storage batteries (1) are connected in series-parallel with the negative terminal grounded.

ELECTRICAL SYSTEM - Continued

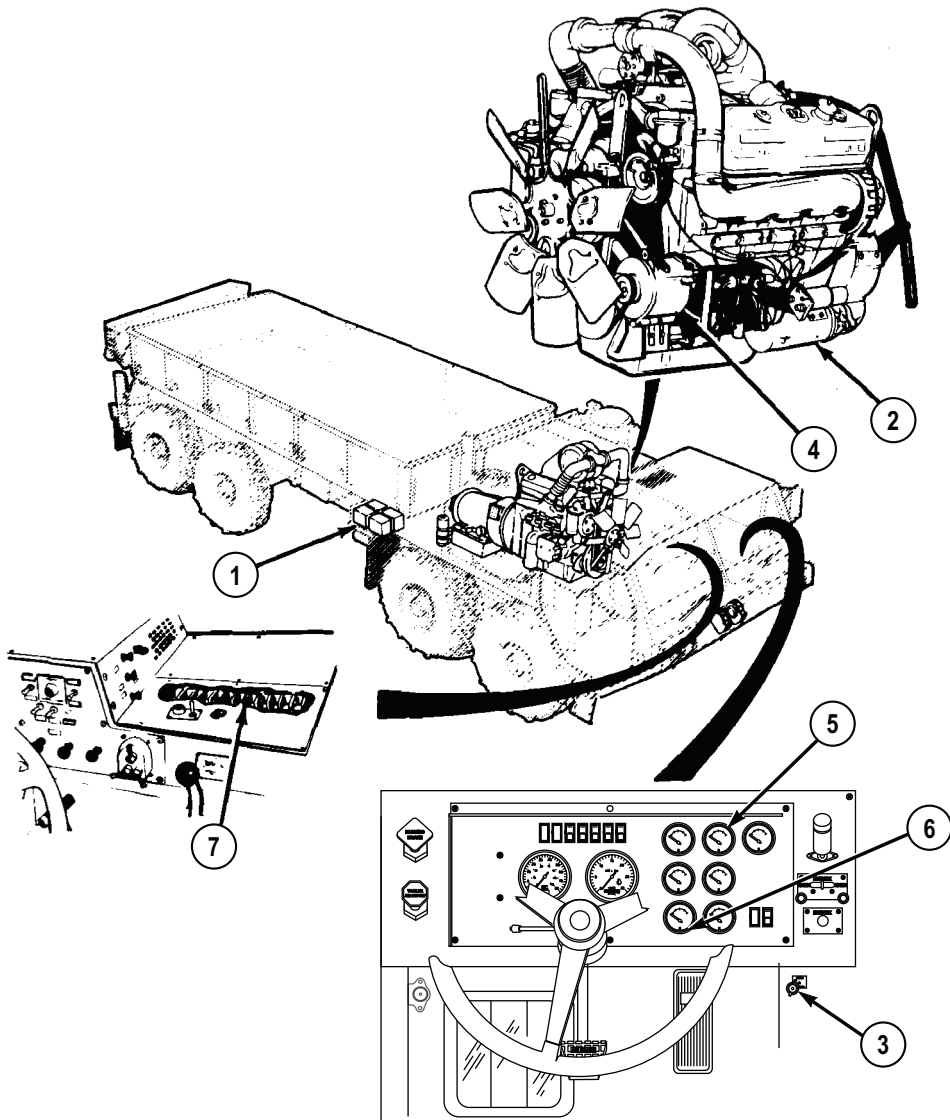

Figure 1.

The heavy-duty starting motor (2) operates directly from the 24 VDC source through the engine start switch (3).

A belt-driven 24 VDC alternator (4) having a capacity of 65 amps (M983 - 100 amps) or 130 amps maintains the charge on the batteries.

ELECTRICAL SYSTEM - Continued

The AMPERES gauge (5) shows the alternator output.

The BATTERY gauge (6) shows the state of charge of the batteries and alternator voltage output.

The vehicle electrical circuits are protected against overloads by automatic reset circuit breakers (7) located below the heater compartment panel.

MAJOR ELECTRICAL SYSTEM COMPONENT LOCATION

The voltage and the current for the electrical system are indicated by a battery gauge (1) and an ammeter (2) located on the dash panel inside the driver's compartment.

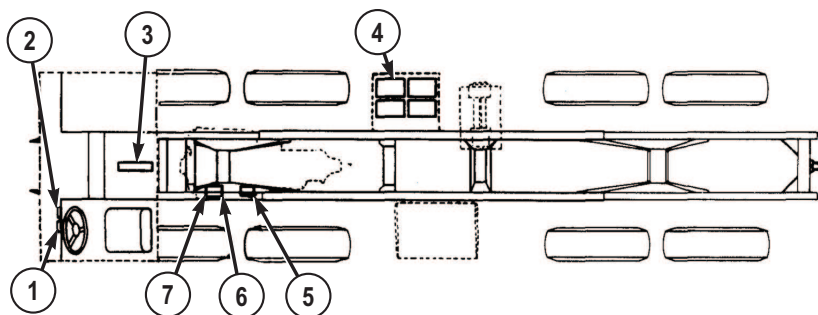

Figure 2.

Circuit breakers (3) located in the cab protect the main circuits.

Electrical power is provided by four 12-volt series-parallel connected batteries (4).

NOTE

Power is distributed throughout the vehicle by wiring harnesses. The harnesses are interconnected by pin connectors. Connectors are provided at the rear of the vehicle to supply power for towed loads.

A heavy-duty starting motor (5) is mounted on the engine flywheel housing and provides the cranking power necessary for starting the engine.

The voltage regulator (6) is mounted on the belt driven alternator (7) and maintains a 24-volt level for battery charging.

END OF WORK PACKAGE

**OPERATOR MAINTENANCE
AIR SYSTEM**

AIR SYSTEM

The air system consists of an engine-driven air compressor (1) and four air reservoirs (2, 3, 4, and 5).

AIR SYSTEM - Continued

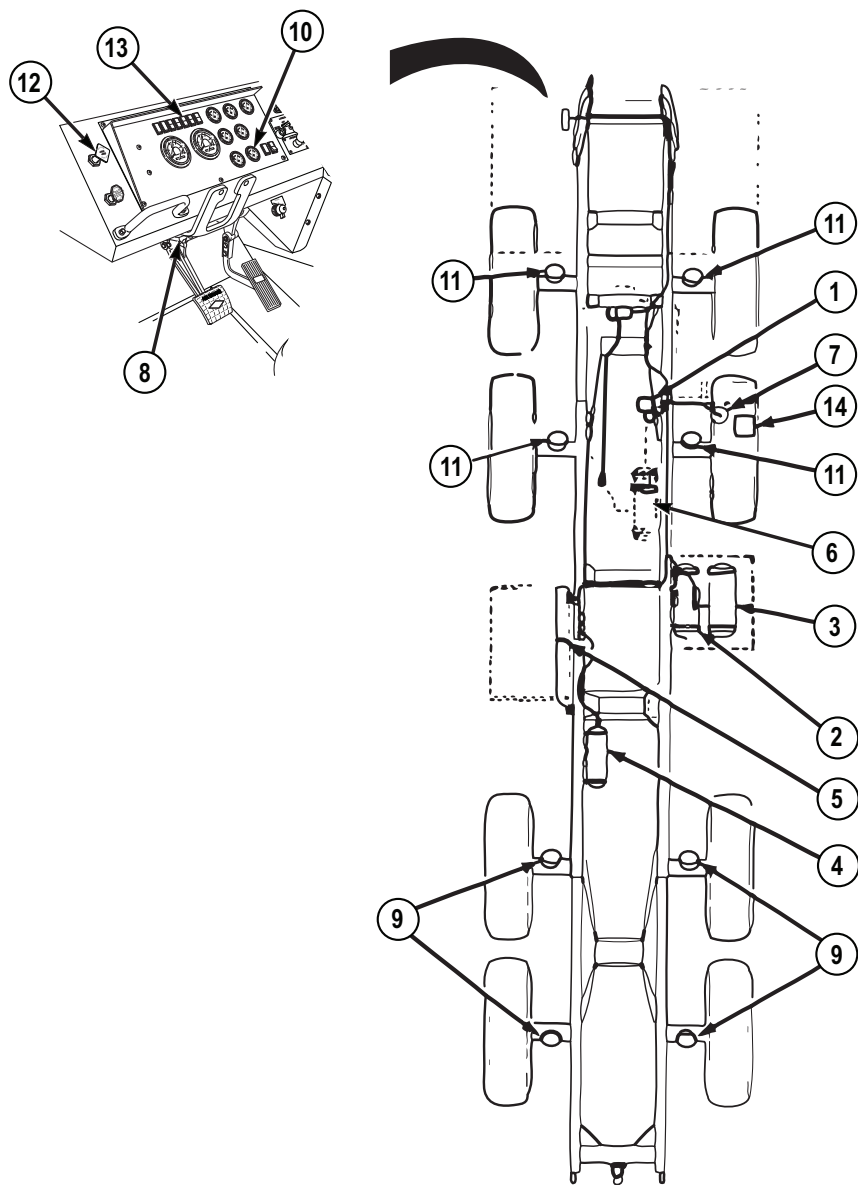

Figure 1.

Reservoir (4) is used on all vehicles except the M983 tractor, which has a reservoir (6) instead.

AIR SYSTEM - Continued**NOTE**

The air system includes the necessary valves and air lines to control the vehicle's air-operated parts.

Pressurized air from the air compressor (1) is passed through the air dryer (7) to the quick buildup reservoir (2). The air dryer (7) removes dirt and moisture from the pressurized air.

Once air pressure in reservoir (2) rises above 75 psi (517 kPa), a valve opens and allows reservoirs (3, 4, or 6, and 5) to be pressurized up to 120 psi (827 kPa).

Air from reservoir (4 or 6) goes to the brake treadle valve (8). This air controls the rear axle service parking brakes (9). Air pressure in this system is shown by the red needle on the AIR PRESS gauge (10).

Air from reservoir (3) goes to the brake treadle valve (8). This air controls the front axle service brakes (11). Air pressure in this system is shown by the green needle on the AIR PRESS gauge (10).

The PARKING BRAKE valve (12) controls air from reservoirs (3 and 5) and applies or releases the rear axle service (parking) brakes (9).

Reservoirs (3, 4, or 6, and 5) are interconnected so that if one reservoir fails, air is supplied to release the rear axle service (parking) brakes (9) from whichever reservoir is functioning.

A buzzer will sound and LOW AIR indicator (13) will illuminate if air pressure falls below 60 psi (414 kPa).

NOTE

Later versions of the parking brake valve incorporate an automatic feature that applies the parking brakes when system air pressure drops to 30 psi (206 kPa) or less.

Specific to the M984A2, the front brake actuator valve (14) is used to apply the front axle service brakes (11) when using heavy-duty winch.

END OF WORK PACKAGE

OPERATOR MAINTENANCE MAIN HYDRAULIC SYSTEM

MAIN HYDRAULIC SYSTEM

The main hydraulic system consists of a power take-off (PTO) driven hydraulic pump (1) and a fluid reservoir (2) shared with the power steering hydraulic system.

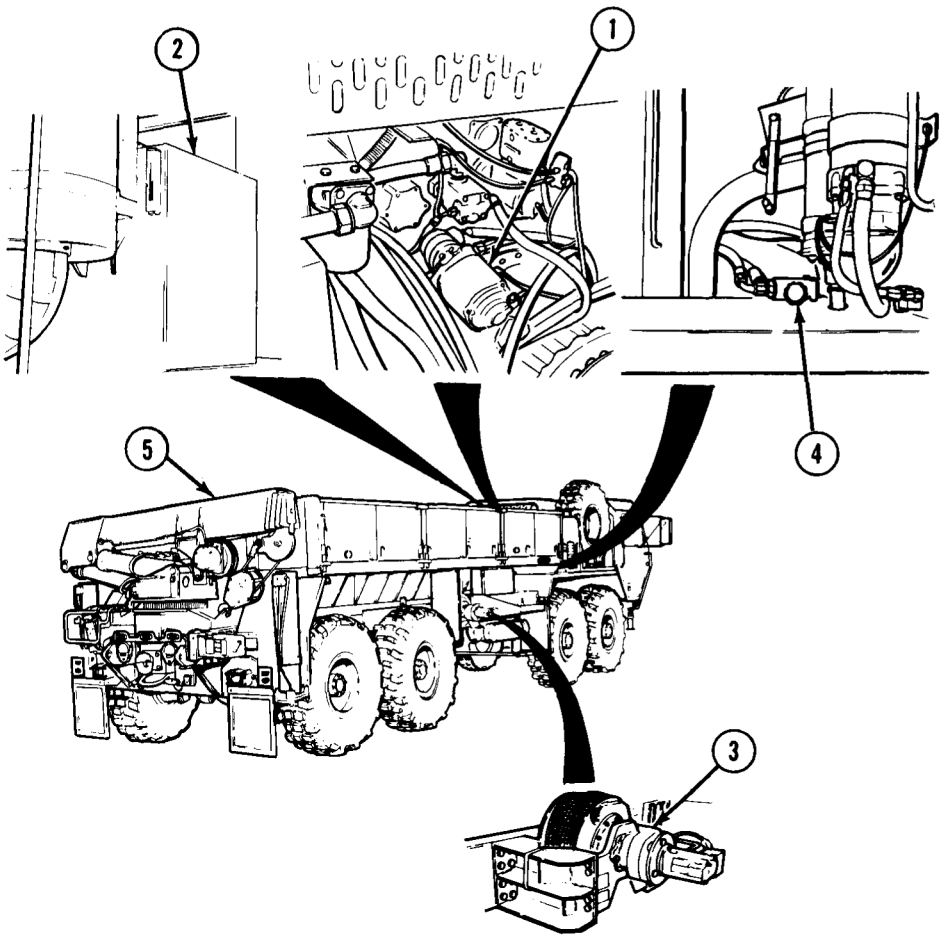

Figure 1.

Any vehicle may also be equipped with a self-recovery winch (3) and a selector valve (4).

MAIN HYDRAULIC SYSTEM - Continued

The main hydraulic system includes the material handling crane (5) on the HEMTT series vehicle.

The fuel pump on the M978 tanker is part of the main hydraulic system.

FLUID SYSTEM

Pump (1) mounted on the rear of engine provides the fluid power to operate the power steering (2) only.

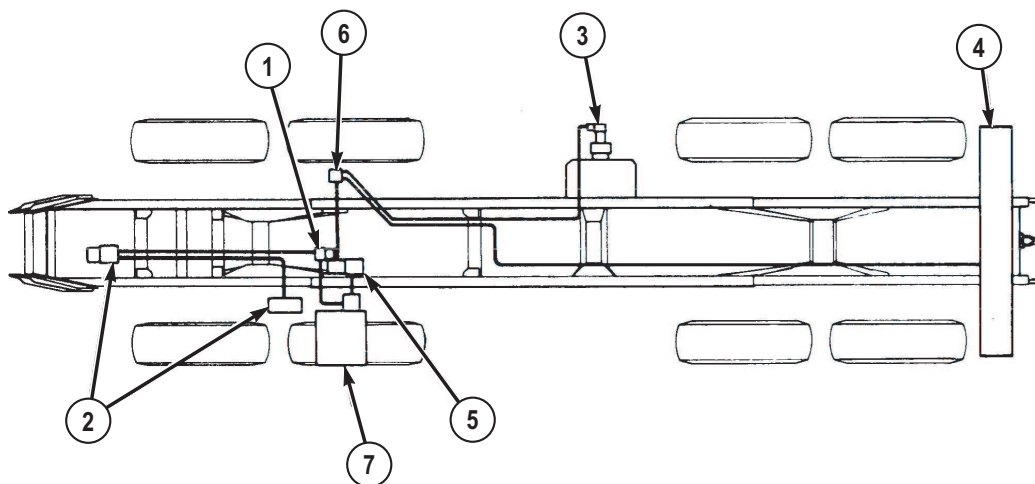

Figure 2.

Fluid power for the self-recovery winch (3), crane (4), and fuel tanker dispensing components (M978 only) is provided by a hydraulic pump (5) driven by the power take-off (PTO) mounted on the transmission.

A manually-operated selector valve (6) is used to activate either the self-recovery winch (3), crane (4), fuel tanker dispensing components (M978 only), or load handling system (LHS) on M1120 LHS and M1977 CBT.

Both pumps (1) and (5) share the same reservoir (7).

END OF WORK PACKAGE

OPERATOR MAINTENANCE STEERING SYSTEM

POWER STEERING HYDRAULIC SYSTEM

Power is supplied to the main steering gear (1) by an engine-driven pump (2).

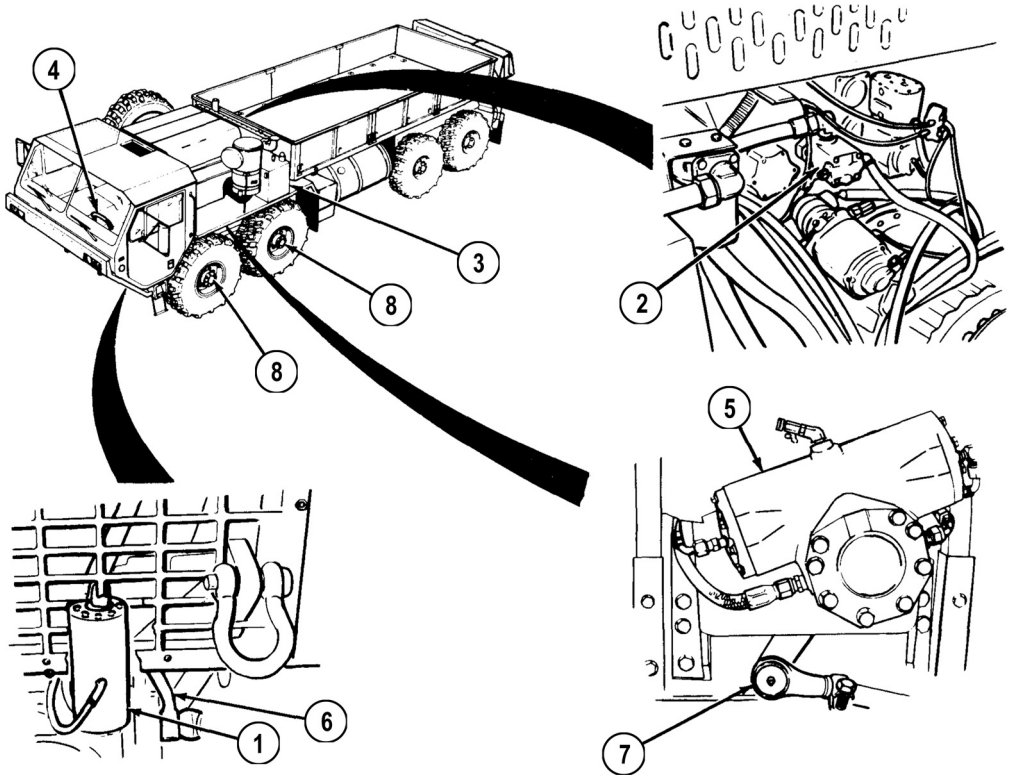

Figure 1.

The fluid reservoir (3) is shared with the main hydraulic system.

The steering wheel (4), which is mechanically linked to the main steering gear (1), rotates a gear that positions a spool in the main steering gear.

This motion is hydraulically transmitted to a piston in the slave gear (5) causing it to follow the rotation of the main gear.

The main gear pitman arm (6) is mechanically connected to the slave gear pitman arm (7).

POWER STEERING HYDRAULIC SYSTEM - Continued

These pitman arms move the steering mechanism on the front axles (8) left or right causing the vehicle to steer left or right.

END OF WORK PACKAGE

OPERATOR MAINTENANCE POWER TRAIN

POWER TRAIN

NOTE

The operator should be aware of which model transmission their vehicle is equipped with. HEMTT A2 series vehicles may be equipped with either the Allison HD4560 (older) or Allison 4500SP (newer) automatic transmission. The differences between the transmissions are called out throughout this manual.

The drivetrain control system consists of the engine and transmission systems.

The vehicle drivetrain is enhanced through the use of the Detroit Diesel Electronic Control IV (DDEC IV) and a HD4560 electronic transmission controller, or 4500SP Transmission Control Module (TCM).

The DDEC IV and HD4560 or 4500SP transmission (see note above) systems perform self-diagnostics, engine/transmission system diagnostics, and vehicle performance diagnostics.

Self-diagnostics includes personnel-initiated checks of main electronic components such as solenoids, wiring, sensor, and control modules.

System-diagnostics monitor critical engine and transmission parameters such as oil temperature, oil pressure, coolant temperature, voltage, and gear range attained.

Vehicle performance diagnostic capabilities aid the mechanic in isolating problems outside of the electronic control system.

Operating data is stored in the DDEC IV's memory for display at a later time.

Stored data includes total engine hours and fuel consumed.

The DDEC IV also tracks intermittent problems by logging the number of occurrences and the engine hours of each occurrence.

The DDEC IV electronically governs engine speed and can be programmed to accommodate configuration changes.

The DDEC IV is electronically linked with the HD4560 or 4500SP transmission system (see note above) to improve vehicle performance.

Power Train

Power for the vehicle is provided by a diesel engine (1), which is coupled directly to an automatic transmission (2).

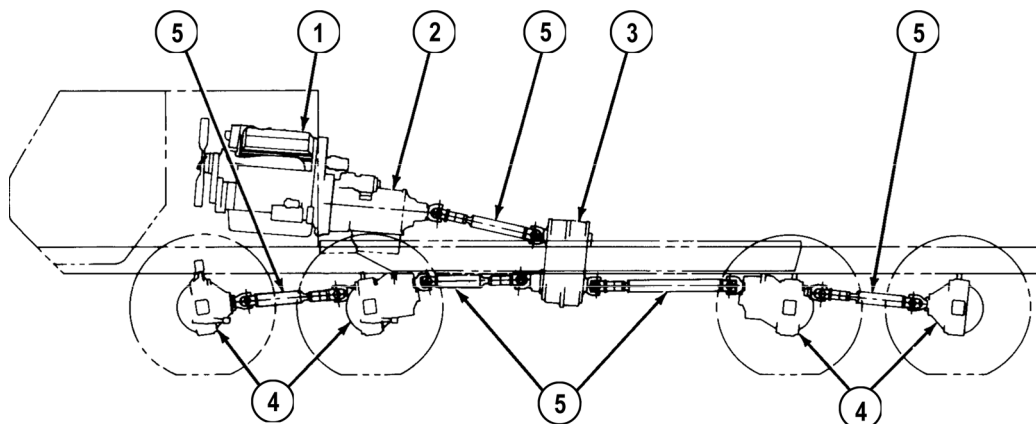
POWER TRAIN - Continued*Figure 1.*

Power from the transmission is transferred to the transfer case (3) and on to front and rear tandem axles (4) through a series of drive shafts and universal joints (5).

AUTOMATIC TRANSMISSION**NOTE**

The operator should be aware of which model transmission their vehicle is equipped with. HEMTT A2 series vehicles may be equipped with either the Allison HD4560 (older) or Allison 4500SP (newer) automatic transmission. The differences between the transmissions are called out throughout this manual.

HEMTT A2 series vehicles are equipped with either a model HD4560 (older), or model 4500SP (newer) Allison HD4000 series transmission.

Both are hydrokinetic type transmissions that have an integral-locking torque converter, lock-up clutch, constant mesh planetary gearing, a speedometer, and control valve module assembly.

NOTE

- The following information is applicable to HEMTT A2 series vehicles equipped with the older HD4560 transmission only.
- Data on the newer 4500SP transmission can be found below HD4560 information.

The primary components of the HD4560 system are an electronic control unit (ECU), transmission range selector in the vehicle cab, a control valve module beneath the

AUTOMATIC TRANSMISSION - Continued

transmission gearing section which contains solenoid valves for clutch control, an engine speed sensor, a turbine speed sensor, and an output speed sensor that relays the transmission output speed to the ECU for shifting and control functions.

AUTOMATIC TRANSMISSION - Continued

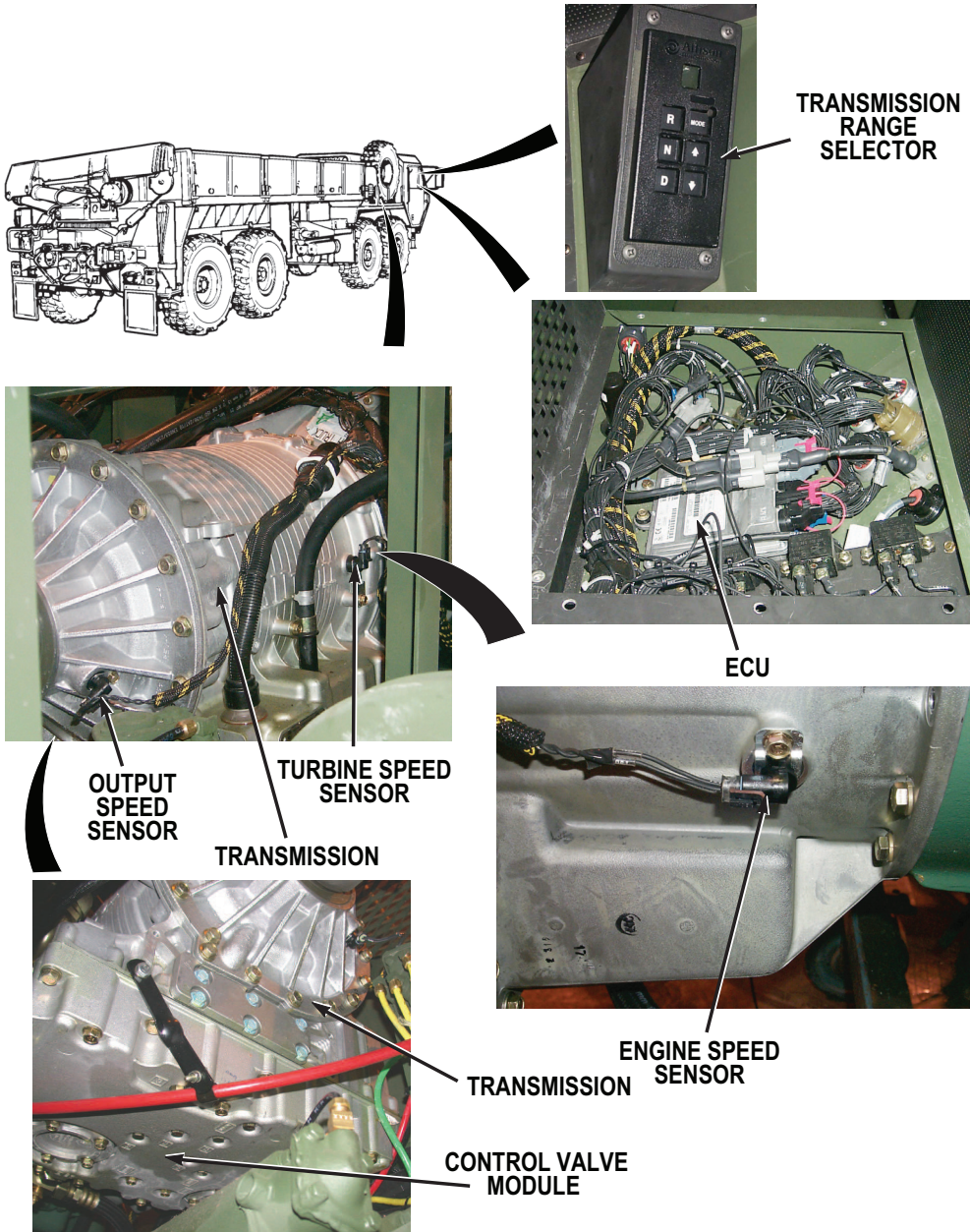

Figure 2.

AUTOMATIC TRANSMISSION - Continued

The ECU, which contains the microprocessor based electronics, is located in a protected area within the vehicle cab.

The ECU receives information, in the form of signals from switches and sensor, processes the information and sends electrical signals to the appropriate components which control the operation.

The ECU features diagnostics which can sense electronic system malfunctions and identify them with a displayable code.

Diagnostic codes can be accessed by two methods: a diagnostic data reader connected to the vehicle at the electronic diagnostic receptacle or through the transmission range selector push buttons.

AUTOMATIC TRANSMISSION - Continued

Figure 3.

The ECU also protects the transmission from cold weather start-ups by inhibiting normal shifting functions until a minimum sump off temperature of 20°F (-7°C) is attained.

A TRANS CHECK light located on the instrument panel alerts the operator, momentarily, every time the system is activated as a lamp check, and when the ECU finds a problem in the system.

If the TRANS CHECK light illuminates during vehicle operation, the transmission will continue to operate normally, in most cases. However, in some cases, the ECU will take action to reduce the possibility of damage to the vehicle or the transmission. The transmission should be serviced at the next opportunity.

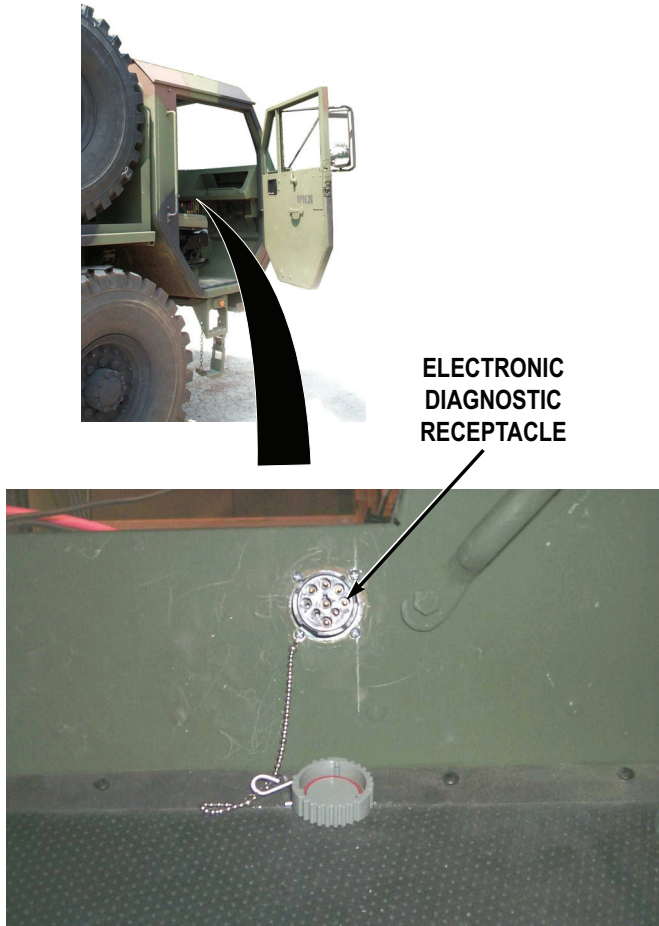
AUTOMATIC TRANSMISSION - Continued

The transmission range selector allows the operator to select a vehicle drive range.

AUTOMATIC TRANSMISSION - Continued

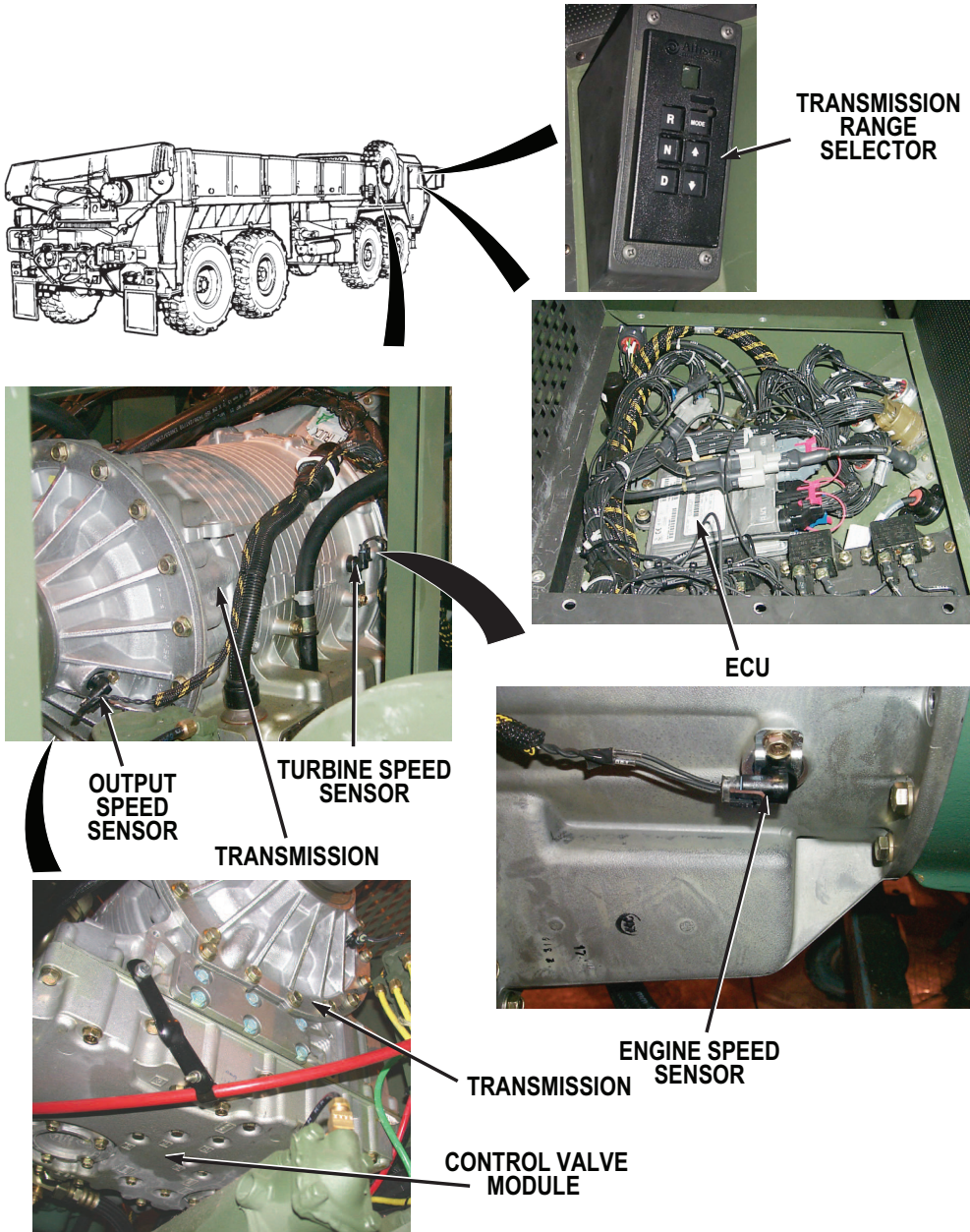

Figure 4.

AUTOMATIC TRANSMISSION - Continued

Operate transmission and transfer case work package (WP 0048) provides full operating instructions for the transmission.

All lubricating and clutch-applied oil is provided by an engine-driven pump (in the transmission).

The transmission includes an electrically-controlled power takeoff (PTO).

The PTO provides power to a hydraulic pump, which powers the vehicle's hydraulic system.

The hydraulic system operates the self-recovery winch, the material handling crane, the heavy-duty recovery winch, and the pumping equipment, depending on how the vehicle is equipped.

NOTE

- The following information is applicable to HEMTT A2 series vehicles equipped with the newer 4500SP transmission only.
- Data on the older HD4560 transmission can be found above.

The primary components of the 4500SP system are the Transmission Control Module (TCM), transmission range selector in the vehicle cab, a control valve module beneath the transmission gearing section which contains solenoid valves for clutch control, an engine speed sensor, a turbine speed sensor, and an output speed sensor that relays the transmission output speed to the TCM for shifting and control functions.

AUTOMATIC TRANSMISSION - Continued

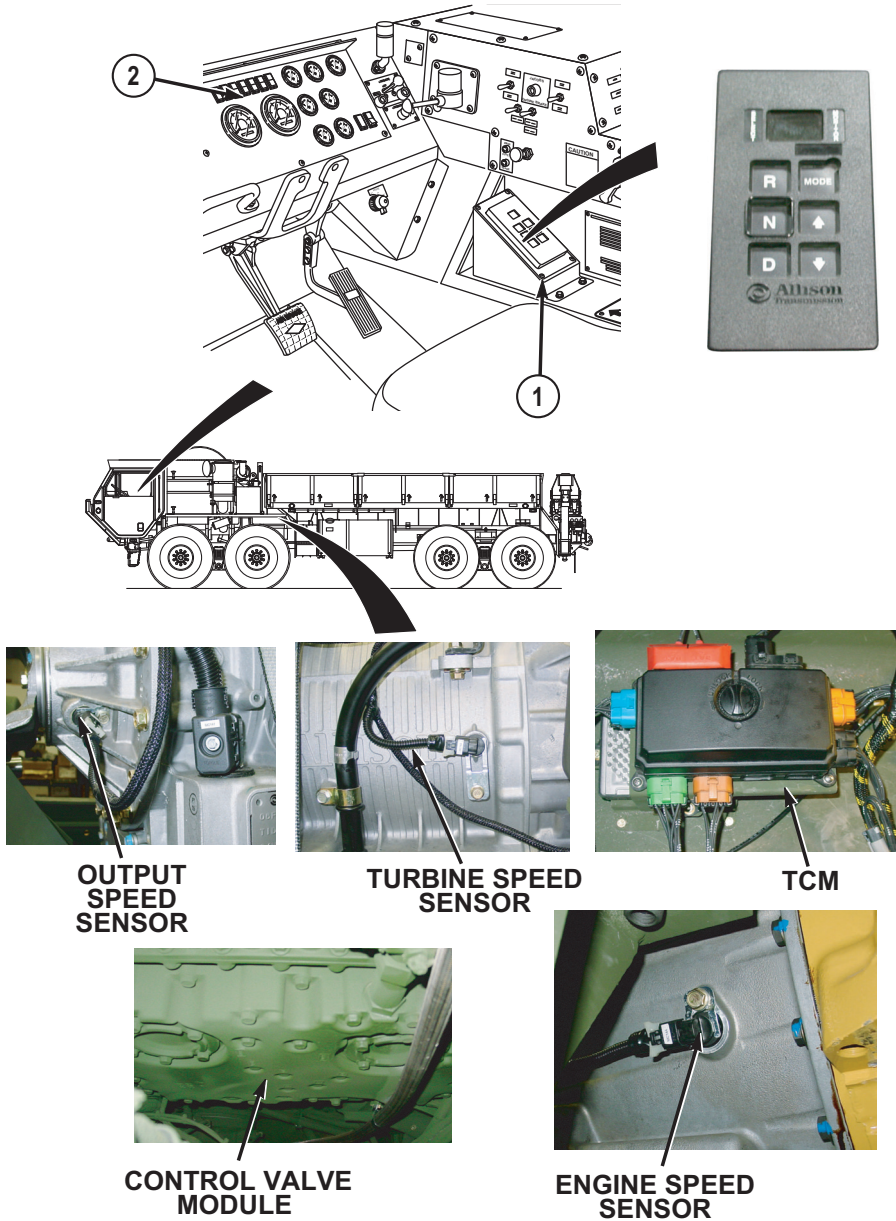

Figure 5.

AUTOMATIC TRANSMISSION - Continued

The TCM also protects the transmission from cold weather startups by inhibiting normal shifting functions until a minimum sump temperature of 20°F (-7°C) is attained.

A check transmission indicator (2) located on the instrument panel alerts the operator, momentarily, every time the system is activated as a lamp check, and when the TCM finds a problem in the system.

If check transmission indicator (2) comes on during vehicle operation, the transmission will continue to operate normally, in most cases. However, in some cases, the TCM will take action to reduce the possibility of damage to the vehicle or the transmission (refer to limp home/transmission fault (WP 0105) for more information. The transmission should be serviced at the next opportunity.

The transmission range selector (1) allows the operator to select a vehicle drive range.

Operate transmission and transfer case (WP 0048) provides full operating instructions for the transmission.

The TCM contains the microprocessor based electronics and is located in a protected area within the vehicle cab.

The TCM receives information in the form of signals from switches and sensor, processes the information, and sends electrical signals to the appropriate components, which control the operation.

The TCM features diagnostics, which can sense electronic system malfunctions and identify them with a displayed code.

Diagnostic codes can be accessed by two methods: a diagnostic data reader connected to the vehicle at the electronic diagnostic receptacle or through the transmission range selector (1) push buttons.

AUTOMATIC TRANSMISSION - Continued

Figure 6.

All lubricating and clutch-applied oil is provided by an engine-driven pump (in the transmission).

The transmission includes an electrically-controlled power take-off (PTO).

The PTO provides power to a hydraulic pump, which powers the vehicle's hydraulic system.

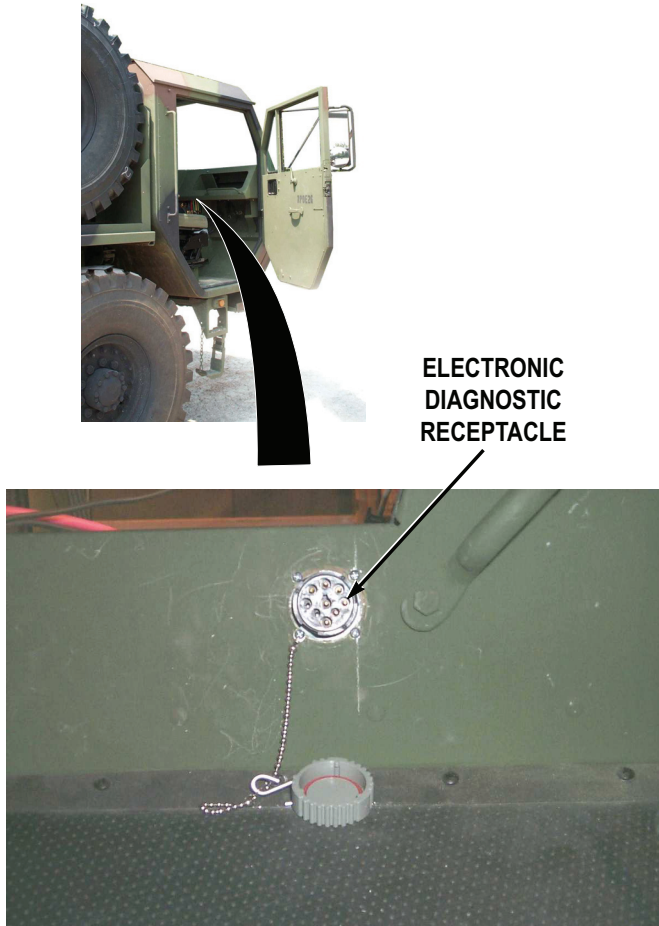
The hydraulic system operates the self-recovery winch, the material handling crane, the heavy-duty recovery winch, and the pumping equipment, depending on how the vehicle is equipped.

TRANSFER CASE

The transfer case (1) connects the drivetrain to the No.1 and No. 2 axles (2) when 8-wheel drive is needed.

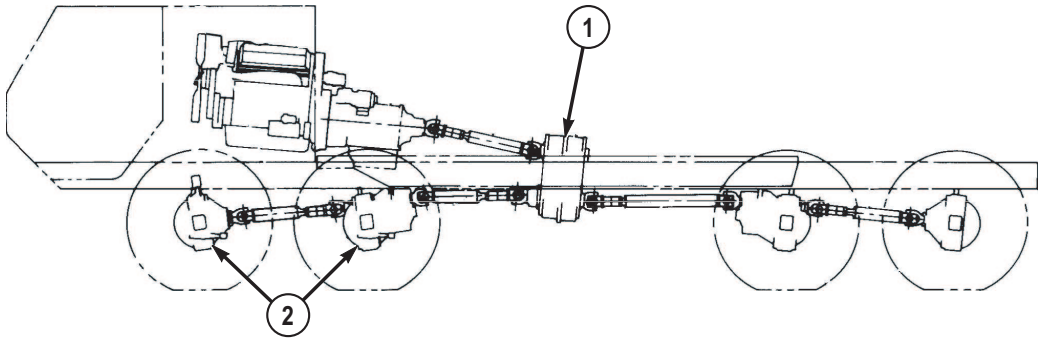

Figure 7.

The transfer case has two gear ratios (high and low) and neutral. The vehicle must be stopped before the transfer case can be shifted between ranges because the gears are not synchronized.

Engagement of the transfer case in low range will automatically engage the drivetrain to the front axles.

TANDEM AXLES AND SUSPENSION

Front and rear tandem axles (1) are single reduction, full floating axle shaft type.

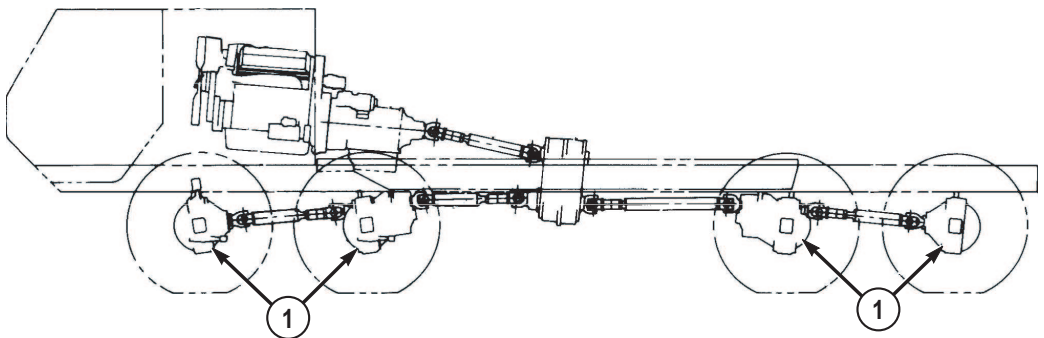

Figure 8.

The front tandem provides steering

The rear tandem is non-steering.

TANDEM AXLES AND SUSPENSION - Continued

Both front and rear tandems are equipped with wheel differentials and inter-axle differentials.

The inter-axle differential have driver-controlled lockouts for positive drive to all axles in low range.

The rear tandem is equipped with permanently engaged controller traction differentials.

The front and rear suspensions are tandem axle type with leaf springs and equalizing beams.

PROPELLER SHAFTS AND UNIVERSAL JOINTS

The propeller shafts and universal joints (1) transmit engine power to the axles.

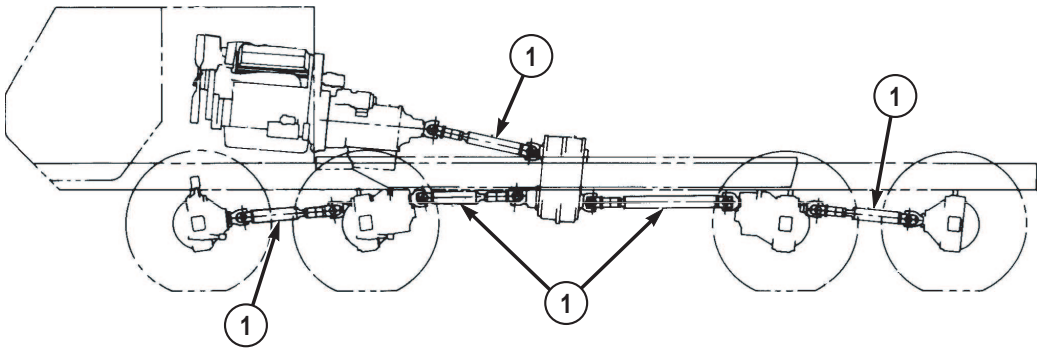

Figure 9.

END OF WORK PACKAGE

OPERATOR MAINTENANCE ENGINE SYSTEMS

ENGINE

The vehicle is equipped with a Detroit Diesel Corporation (DDC) Model 8V92TA engine and is controlled by a DDEC IV system.

The primary components of the DDEC IV system are the Electronic Control Module (ECM), and Electronic Unit Injector (EUI), and Engine Sensor.

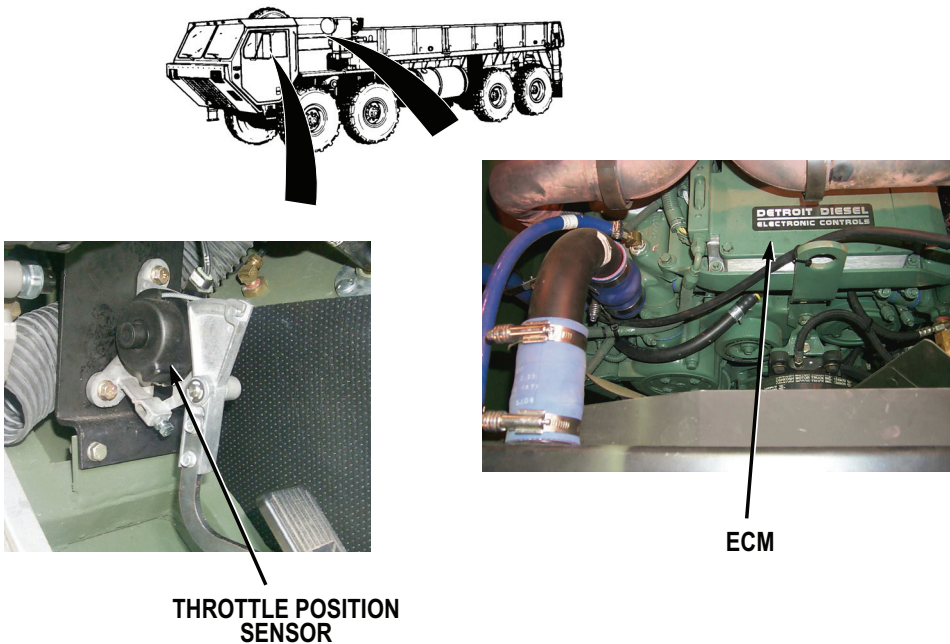

Figure 1.

The ECM contains a microprocessor that continuously monitors and analyzes the DDEC IV system with electronic sensors during engine operation.

A programmable read only memory (PROM) provides basic engine control function instructions.

An electronically erasable, programmable, read only memory (EEPROM) stores engine calibration values.

ENGINE - Continued

A backup EEPROM and microprocessor monitors and analyzes engine operation should the main microprocessor fail and a throttle position sensor (TPS) input, which is activated by the accelerator pedal.

The EUI allows precise metering and injection timing.

The Engine Sensors monitor key parts of the engine for performance and environmental variables.

The ECM features diagnostics, which can sense electronic system malfunctions and identify them with a displayable code.

The DDEC IV protects the engine from serious damage by alerting the operator of engine malfunctions.

A CHECK ENGINE light, on the instrument panel, will light up when a non-critical fault occurs, but the vehicle can still be operated.

When oil/water light goes off, shut vehicle off immediately. Oil/water light has a buzzer that will sound.

Diagnostic codes can be accessed by a PC based software program or a Diagnostic Data Reader connected to the vehicle at the Electronic Diagnostic Receptacle.

ENGINE - Continued

Figure 2.

AIR INTAKE SYSTEM

The air intake system consists of a dry type air cleaner (1), turbocharger (2), engine blower (3), and an aftercooler (4).

AIR INTAKE SYSTEM - Continued

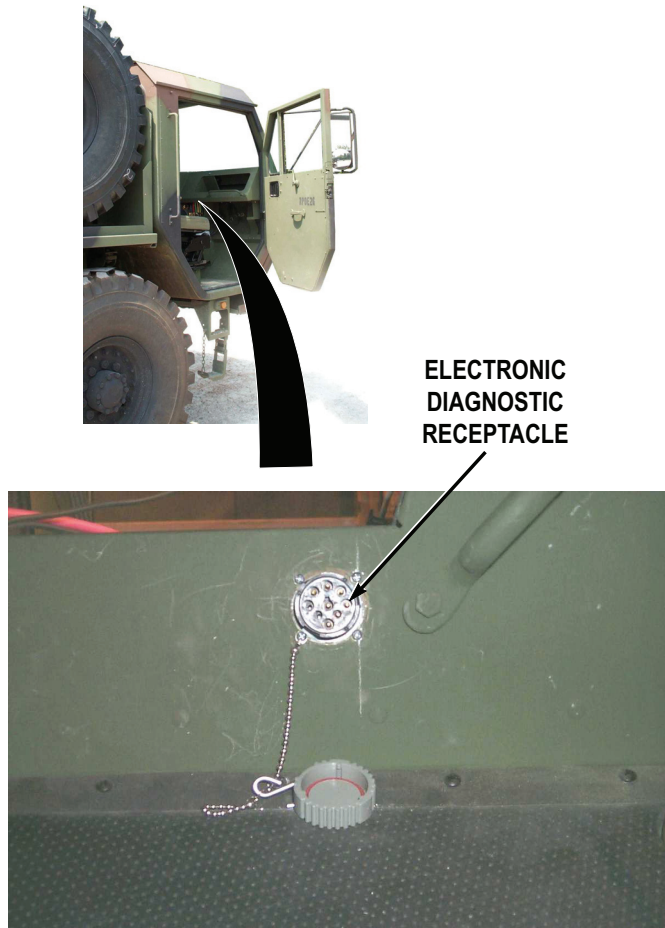
Figure 3.

Engine exhaust gases flow through the turbocharger (2) driving a turbine wheel.

A compressor wheel on the opposite end of the turbine wheel shaft rotates and draws in fresh air through the air cleaner (1), compresses the air, and delivers it to the engine blower (3).

Air from the engine blower (3) flows through the aftercooler (4) which cools the air before it is delivered to the engine cylinders.

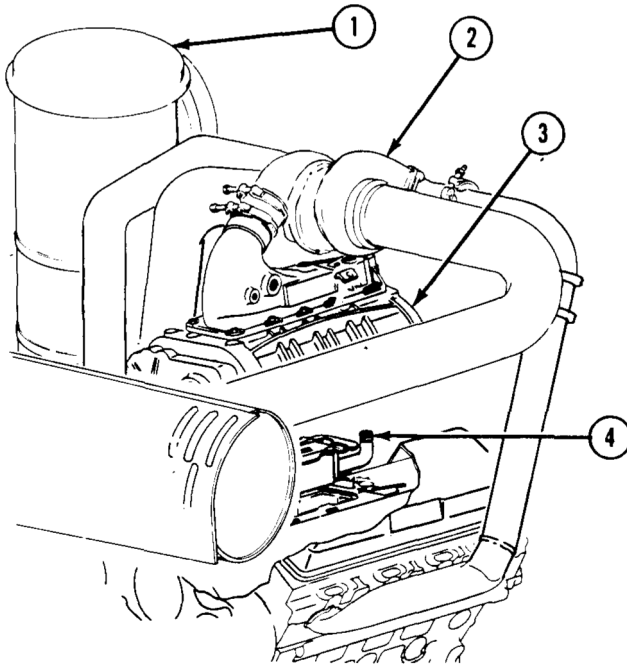
FUEL SYSTEM

Fuel drawn from the fuel tank (1) passes through the supply line (2) to a fuel/water separator (3), fuel pump (4), and secondary filter (5) to the engine fuel injectors (6).

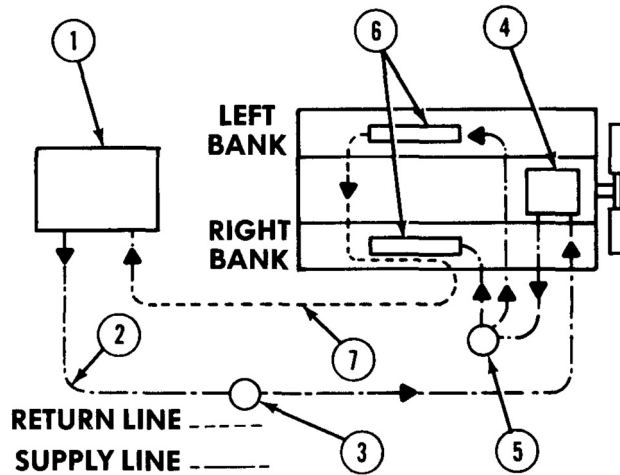
FUEL SYSTEM - Continued*Figure 4.*

Surplus fuel from injectors is returned to the fuel tank (1) through the return line (7).

NOTE

The fuel/water separator removes water and large solid particles from the fuel.

The finer particles are removed by the secondary filter (5) before they can enter the fuel injectors.

COOLING SYSTEM**NOTE**

The pressure type cooling system protects the engine by removing heat generated during the combustion process.

Pressure within the cooling system is regulated by a pressure release in the radiator filler cap (1).

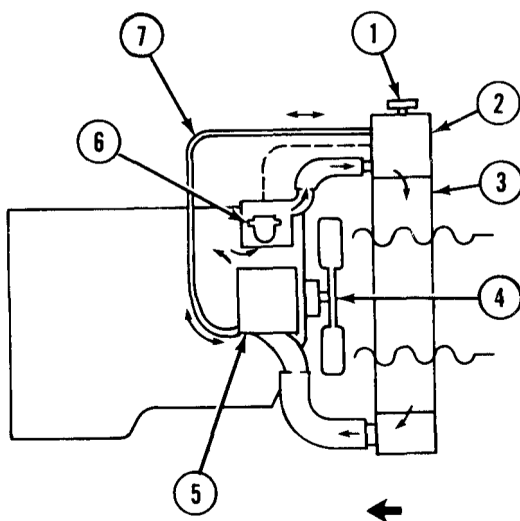
COOLING SYSTEM - Continued*Figure 5.*

The hot coolant flows from the engine to top of radiator tank (2) and through radiator core (3) where a stream of air removes heat.

This stream of air is drawn through the core by an air-activated fan (4).

A water pump (5) draws the coolant from the bottom of the radiator and pushes it through the engine repeating the cooling process.

Thermostats (6), mounted in each coolant outlet elbow, remain closed until the coolant approaches a predetermined temperature at which time they open.

NOTE

When the coolant temperature drops below the thermostatic rating, the thermostats close.

An air vent line (7) between the radiator (2) and the water pump (5) inlet removes air trapped in the engine when the cooling system is being filled.

END OF WORK PACKAGE

**OPERATOR MAINTENANCE
CAB**

CAB

The cab (1) contains all of the driving controls and gauges, operating controls for some of the mounted equipment, and adjustable seats for a crew of two. For explanation of cab controls, refer to vehicle controls and indicators.

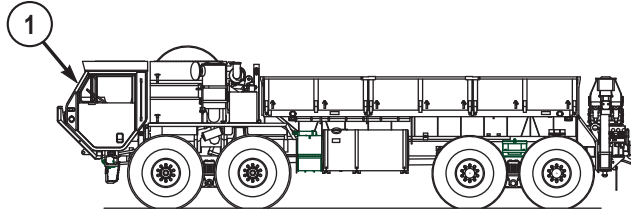

Figure 1.

END OF WORK PACKAGE

**OPERATOR MAINTENANCE
WHEELS AND TIRES**

WHEELS AND TIRES

There are four front and four rear steel disc, 20.00 x 10.00 wheels (1) with 16.00 R20, tubeless, radial traction, non-directional tires.

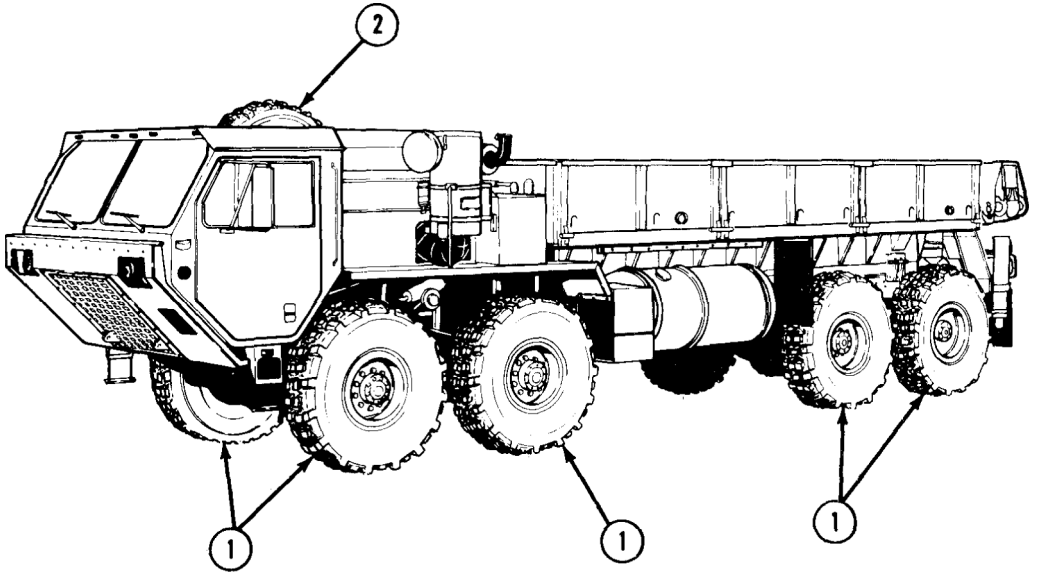

Figure 1.

One spare tire (2) is mounted to the passenger side of vehicle.

END OF WORK PACKAGE

OPERATOR MAINTENANCE CRANE

CRANE OVERVIEW

The cranes are operated by two functional systems: the electrical system and the hydraulic system.

A number of cranes are used on the HEMTT series vehicles:

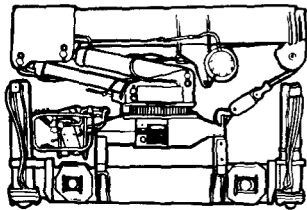

M977 CARGO VEHICLE

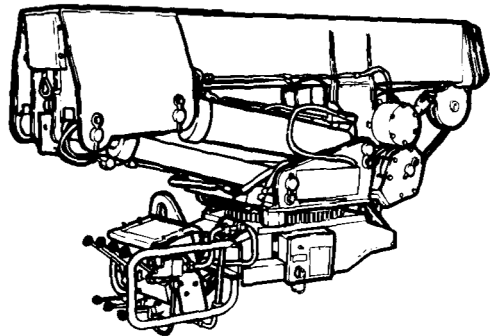

M985 CARGO VEHICLE

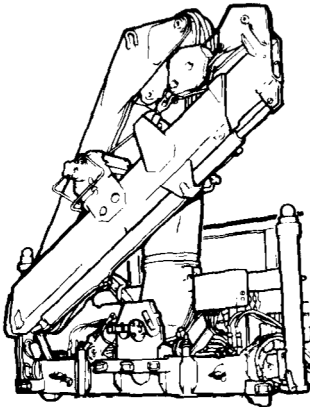

M985 E1/GMT CARGO VEHICLE

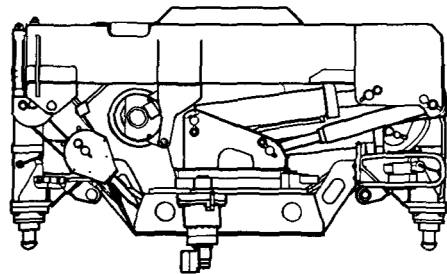

**M984
WRECKER-RECOVERY VEHICLE**

Figure 1.

Refer to operator's manuals for specifications, dimensions, and operating procedures for the different crane models.

The cranes are completely hydraulic powered and their principles of operation are the same.

CRANE OVERVIEW - Continued

Individual control panel, boom-hydraulic cylinder arrangements, and lifting capacities are different.

All cranes are powered from the vehicle's hydraulic system.

All are equipped with outriggers for stability during operation.

All cranes use a combination of hinged joints and telescoping members to give them their motions.

The hydraulic-powered hoisting winch has an automatic brake to prevent accidental lowering of the load.

CRANE OPERATING INSTRUCTION PLATE LOCATIONS

NOTE

Refer to stowage and decal/data plate guide for more information on plate locations.

The crane operating instruction plates are located on the heater compartment cover in the cab at each of the fixed operating stations.

The outrigger leg signs are located on each of the outrigger cylinders.

The load capacity signs are located at the main and auxiliary control panels, and on M984A they are located on the wrecker body rear stowage box doors.

CRANE ELECTRICAL SYSTEM

Material handling cranes for models M977, M984A, and M985 all have overload shutdown and/or tilt warning (unstable) systems.

When M977, M985, and M984A cranes are overloaded, the overload system will automatically shut off power to telescope boom out, raise boom, or hoist load higher. The M977 and M984A overload system will also prevent lowering the boom. An overload condition can be corrected by lowering the boom. An overload condition can be corrected by lowering load to ground or other supporting surface. All functions will be restored in approximately six seconds.

The crane electrical system is supplied with power by the vehicle 24 VDC system.

The junction box on the crane connects and distributes the various control circuits of the crane.

Tilt warning, outrigger extended warning, and remote control systems are electronically controlled.

END OF WORK PACKAGE

CHAPTER 2
OPERATOR
INSTRUCTIONS

OPERATOR MAINTENANCE CAB-MOUNTED FOOT CONTROLS

CONTROLS AND INDICATORS INTRODUCTION

This section displays the location and describes the use of cab-mounted foot controls which are used in the operation of HEMTT series vehicles. Controls and indicators described in this section are the same for all vehicles, except where otherwise indicated.

LOCATION AND USE OF CONTROLS AND INDICATORS

Know the location and proper use of every control and indicator before operating HEMTT series vehicles. Separate illustrations with keys are provided for learning about cab-mounted foot controls.

Table 1. Cab-Mounted Foot Controls.

Key	Control/ Indicator	Function
-----	-----------------------	----------

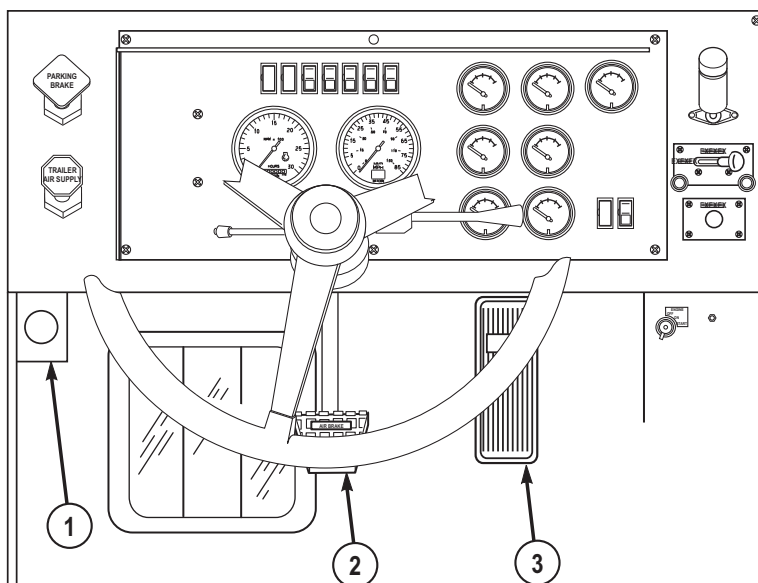

Figure 1.

Table 1. Cab-Mounted Foot Controls. - Continued

Key	Control/ Indicator	Function
1	Headlight Dimmer Switch	Press switch to raise or lower headlight beams. High beam indicator will illuminate (blue) when high beams are on (WP 0021).
2	Service Brake Pedal	Applies service brakes. If vehicle is properly coupled to a trailer, trailer brakes will also operate when vehicle service brakes are applied.
3	Throttle Pedal	Controls vehicle speed.

END OF WORK PACKAGE

OPERATOR MAINTENANCE CAB-MOUNTED HAND CONTROLS

CONTROLS AND INDICATORS INTRODUCTION

This section displays the location and describes the use of cab-mounted hand controls which are used in the operation of HEMTT series vehicles. Controls and indicators described in this section are the same for all vehicles, except where otherwise indicated.

LOCATION AND USE OF CONTROLS AND INDICATORS

Know the location and proper use of every control and indicator before operating HEMTT series vehicles. Separate illustrations with keys are provided for learning about cab-mounted hand controls.

Table 1. Cab-Mounted Hand Controls.

Key	Control/ Indicator	Function
-----	-----------------------	----------

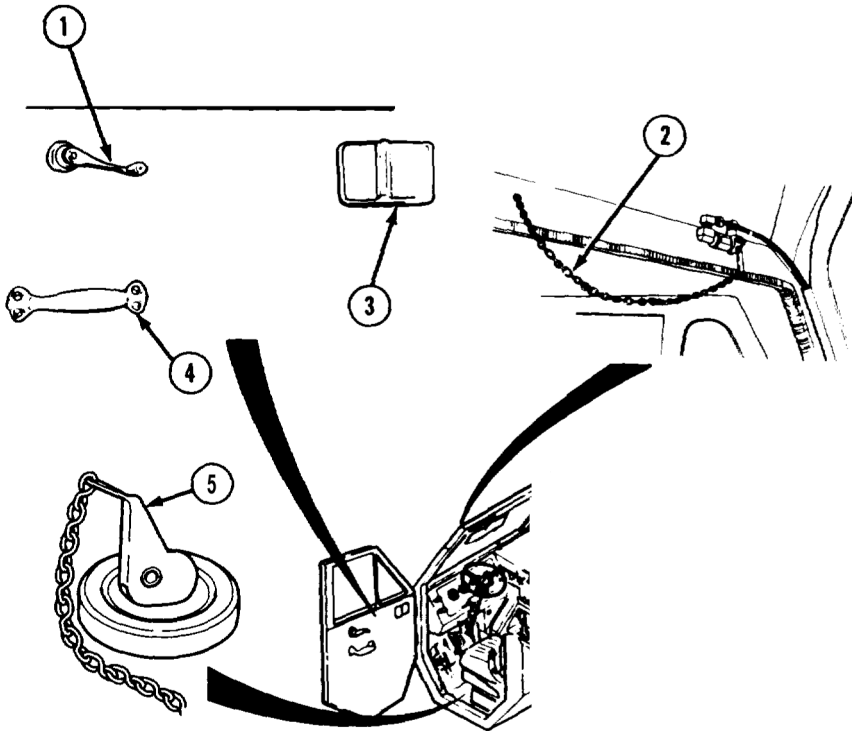

Figure 1.

1	Cab Door Window Glass Regulator (one on each door)	Rotate driver side regulator counterclockwise to lower left window glass, clockwise to raise left window glass. Rotate passenger side regulator clockwise to lower right window glass, counterclockwise to raise right window glass.
2	Air Horn Chain	Pull chain to sound air horn. Release chain to silence air horn.
3	Cab Door Inside Handle	Pull to open cab door from inside of cab.

Table 1. Cab-Mounted Hand Controls. - Continued

Key	Control/ Indicator	Function
	(one on each door)	
4	Cab Door Handle (one on each door)	Pull to close cab door from inside of cab.
5	Drain Plug (one under both operator seat and crew seat)	Pull up on lever to remove drain plug and drain liquid from floor of cab.

END OF WORK PACKAGE

**OPERATOR MAINTENANCE
STEERING COLUMN MOUNTED CONTROLS**

CONTROLS AND INDICATORS INTRODUCTION

This section displays the location and describes the use of steering column mounted controls which are used in the operation of HEMTT series vehicles. Controls and indicators described in this section are the same for all vehicles, except where otherwise indicated.

LOCATION AND USE OF CONTROLS AND INDICATORS

Know the location and proper use of every control and indicator before operating HEMTT series vehicles. Separate illustrations with keys are provided for learning about steering column mounted controls.

Table 1. Steering Column Mounted Controls.

Key	Control/ Indicator	Function
-----	-----------------------	----------

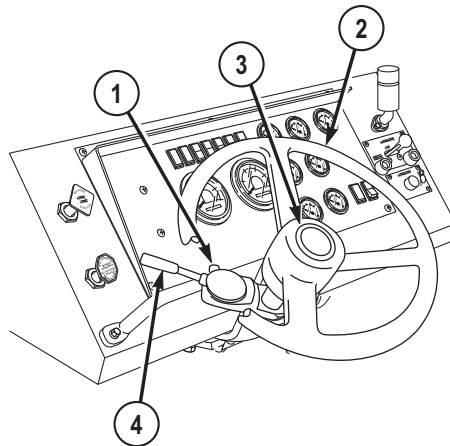

Figure 1.

1	Emergency Flasher Control	To turn on emergency flashers, light control must be in STOP LIGHT or SER DRIVE (WP 0022). Simultaneously press emergency flasher control (1) down and push turn signal lever (4) up past the right turn position as far as it will go. To turn emergency flashers off, push turn signal lever (4) down to center position.
---	---------------------------	---

Table 1. Steering Column Mounted Controls. - Continued

Key	Control/ Indicator	Function
2	Steering Wheel	Controls direction of vehicle.
3	Horn Button	Sounds electric horn when pressed. Release to silence horn.
4	Turn Signal Lever	Push up to signal right turn. Pull down to signal left turn. When turn is complete, return lever to center position.

END OF WORK PACKAGE

OPERATOR MAINTENANCE TUNNEL PANEL CONTROLS AND INDICATORS

CONTROLS AND INDICATORS INTRODUCTION

This section displays the location and describes the use of tunnel panel controls and indicators which are used in the operation of HEMTT series vehicles. Controls and indicators described in this section are the same for all vehicles, except where otherwise indicated.

LOCATION AND USE OF CONTROLS AND INDICATORS

Know the location and proper use of every control and indicator before operating HEMTT series vehicles. Separate illustrations with keys are provided for learning about tunnel panel controls and indicators.

Table 1. Tunnel panel controls and indicators.

Key	Control/ Indicator	Function
-----	--------------------	----------

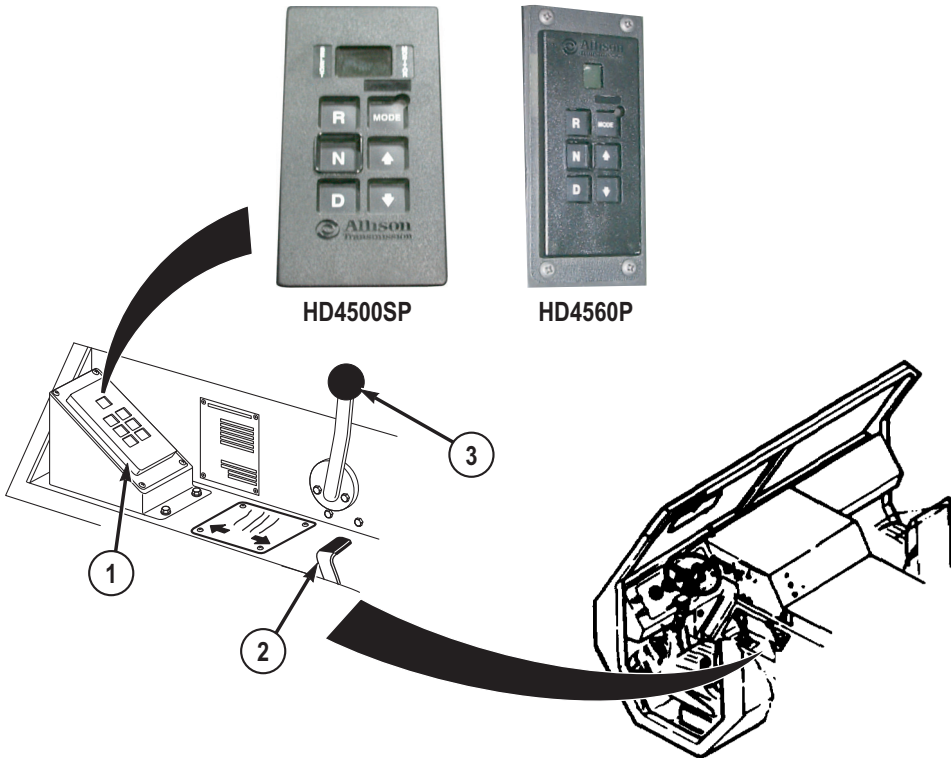

Figure 1.

1 Transmission Range Selector R (reverse) - Used to back up vehicle.

N (neutral) - Used when starting vehicle, parking vehicle, or if vehicle controls are left unattended while engine is running.

D (drive) - Used for all normal driving conditions. When vehicle is in motion, transmission will upshift/downshift automatically.

Table 1. Tunnel panel controls and indicators. - Continued

Key	Control/ Indicator	Function
		UP ARROW (increase) - Once the D (drive) is pressed, pressing the (increase) button allows the operator to override the automatic function of the transmission and shift to a higher gear range. Pressing the D (drive) button returns the transmission to its automatic function.
		DOWN ARROW (decrease) - Once the D (drive) is pressed, pressing the (decrease) button allows the operator to override the automatic function of the transmission and shift to a lower gear range. Pressing the D (drive) button returns the transmission to its automatic function.
		MODE - Used for maintenance/troubleshooting procedures.
2	Self-Recovery Winch (SRW) Lever	Used to pay out (push lever forward) and take up (pull lever aft) winch cable. Lever will return to neutral (center) position when released. Lever not included in vehicles without SRW.

Table 1. Tunnel panel controls and indicators. - Continued

Key	Control/ Indicator	Function
3	TRANSFER CASE Shift Lever	Used to select high (HI) or low (LO) range. Center position is neutral (NEUT).

Figure 2.

4	STE/ICE Receptacle	Receptacle for connecting simplified test equipment/internal combustion engine (STE/ICE).
5	Electronic Diagnostic Receptacle	Receptacle for connecting test equipment for diagnosing problems with engine and transmission.
6	Utility Outlet	Supplies electrical power to operate portable beacon light (WP 0074) and portable work lamp. (WP 0065)

Table 2. Tunnel panel controls and indicators.

Key	Control/ Indicator	Function
-----	--------------------	----------

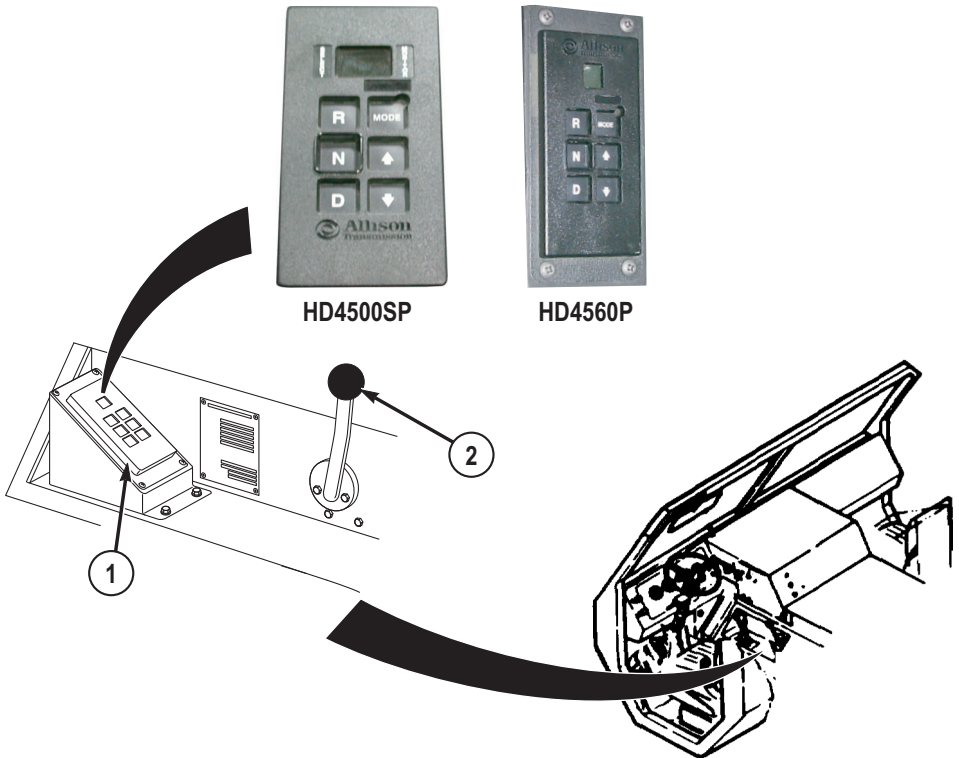

Figure 3.

1 Transmission Range Selector R (reverse) - Used to back up vehicle.

N (neutral) - Used when starting vehicle, parking vehicle, or if vehicle controls are left unattended while engine is running.

D (drive) - Used for all normal driving conditions. When vehicle is in motion, transmission will upshift/downshift automatically.

Table 2. Tunnel panel controls and indicators. - Continued

Key	Control/ Indicator	Function
		UP ARROW (increase) - Once the D (drive) is pressed, pressing the (increase) button allows the operator to override the automatic function of the transmission and shift to a higher gear range. Pressing the D (drive) button returns the transmission to its automatic function.
		DOWN ARROW (decrease) - Once the D (drive) is pressed, pressing the (decrease) button allows the operator to override the automatic function of the transmission and shift to a lower gear range. Pressing the D (drive) button returns the transmission to its automatic function.
		MODE - Used for maintenance/troubleshooting procedures.

Table 2. Tunnel panel controls and indicators. - Continued

Key	Control/ Indicator	Function
2	TRANSFER CASE Shift Lever	Used to select high (HI) or low (LO) range. Center position is neutral (NEUT).

Figure 4.

3	STE/ICE Receptacle	Receptacle for connecting simplified test equipment/internal combustion engine (STE/ICE).
4	Electronic Diagnostic Receptacle	Receptacle for connecting test equipment for diagnosing problems with engine and transmission.
5	Utility Outlet	Supplies electrical power to operate portable beacon light (WP 0074) and portable work lamp. (WP 0065)

END OF WORK PACKAGE

OPERATOR MAINTENANCE INSTRUMENT PANEL CONTROLS AND INDICATORS

CONTROLS AND INDICATORS INTRODUCTION

This section displays the location and describes the use of instrument panel controls and indicators which are used in the operation of HEMTT series vehicles. Controls and indicators described in this section are the same for all vehicles, except where otherwise indicated.

LOCATION AND USE OF CONTROLS AND INDICATORS

Know the location and proper use of every control and indicator before operating HEMTT series vehicles. Separate illustrations with keys are provided for learning about instrument panel controls and indicators.

Table 1. Instrument Panel Controls and Indicators.

Key	Control/Indicator	Function
-----	-------------------	----------

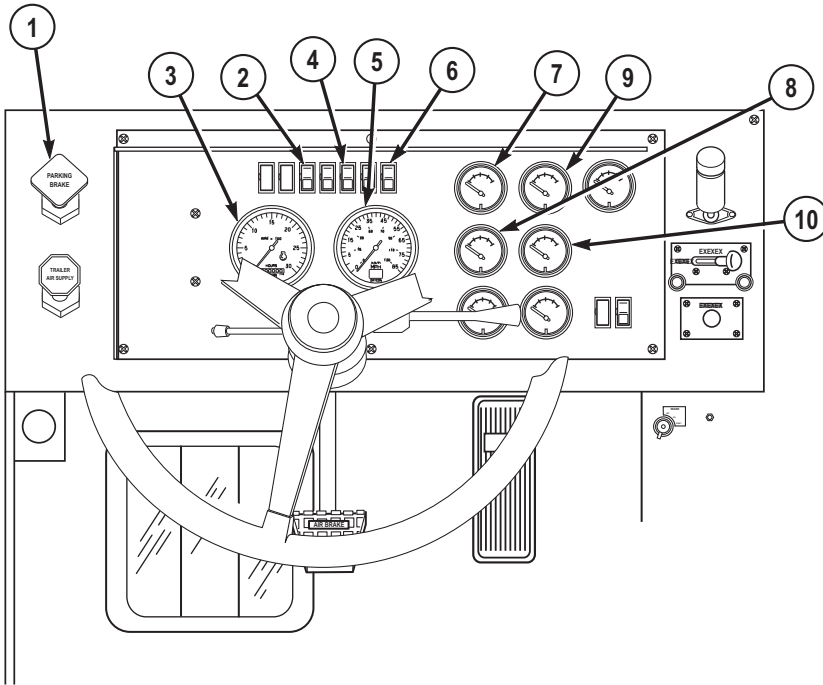

Figure 1.

1	PARKING BRAKE Control	Applies and releases vehicle parking brakes.
2	Left Turn Indicator	Flashes (green) when left turn signal is on.
3	Speedometer/ Odometer	Shows vehicle traveling speed (in MPH and Km/h) and total miles traveled.

Table 1. Instrument Panel Controls and Indicators. - Continued

Key	Control/ Indicator	Function
4	High Beam Indicator	Illuminates (blue) when vehicle headlights are on high beam.
5	Tachometer/ Hourmeter	Displays engine operating speed (RPM x 100) and total operating time (HOURS).
6	Right Turn Indicator	Flashes (green) when right signal is on.
7	FUEL Gauge	Displays amount of fuel in fuel tank.
8	TRANS TEMP Gauge	Displays transmission fluid temperature in degrees Fahrenheit (°F) and Celsius (°C).
9	OIL PRESS Gauge	Displays engine oil pressure (psi and kPa).

Table 1. Instrument Panel Controls and Indicators. - Continued

Key	Control/ Indicator	Function
-----	--------------------	----------

10	WATER TEMP Gauge	Displays engine coolant temperature in degrees Fahrenheit (°F) and Celsius (°C).
----	------------------	--

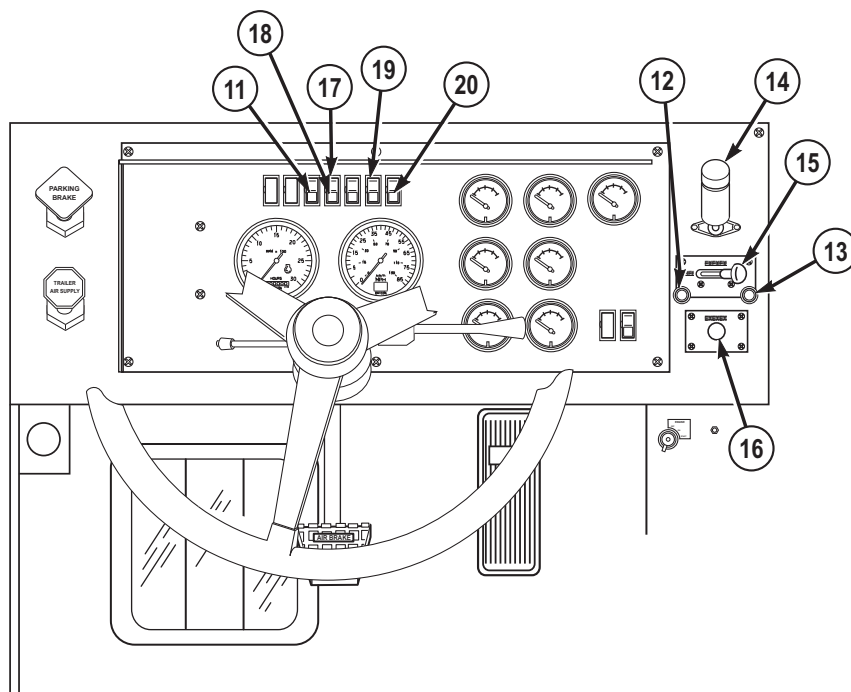

Figure 2.

11	CHECK ENGINE Indicator	Illuminates (amber) when ECM detects a fault in the engine. Engine must be serviced by field level maintenance as soon as possible.
12	INTER-AXLE DIFF. LOCK Indicator	Indicator illuminates (orange) when TRACTION CONTROL is in INTER-AXLES DIFF. LOCK position.

Table 1. Instrument Panel Controls and Indicators. - Continued

Key	Control/ Indicator	Function
13	8x8 DRIVE Indicator	Illuminates (orange) when TRACTION CONTROL is in 8x8 DRIVE position or when TRANSFER CASE is in LO.
14	Air Filter Restriction Indicator	Displays condition of air cleaner filter. Indicator window will show red when filter becomes clogged. VACUUM INCHES H ² O window displays degree of restriction. Push button on top of gauge to reset.
15	TRACTION CONTROL Lever	Lever in left position (INTER-AXLE DIFF. LOCK) locks inter-axle differentials in front and rear tandems. Lever in right position (8x8 DRIVE), engages transfer case drive to front axles.
16	ETHER START Control	Injects ether into engine intake manifold for cold weather starting.
17	TRANS CHECK Indicator	Illuminates (yellow) when ECU detects a problem in the transmission that requires maintenance attention as soon as possible.
18	TRANS TEMP Indicator	Illuminates (red) when transmission oil temperature reaches 250°F (121°C).
19	PARKING BRAKE Indicator	Illuminates (red) when parking brake is activated.
20	CHECK GAUGES Indicator	Illuminates (amber) and is used as a warning to the operator that a potential engine damaging condition has been detected. If indicator is lit, check gauges. If all gauges indicate

Table 1. Instrument Panel Controls and Indicators. - Continued

Key	Control/ Indicator	Function
-----	--------------------	----------

normal condition, complete mission. Notify field level maintenance at completion of mission.

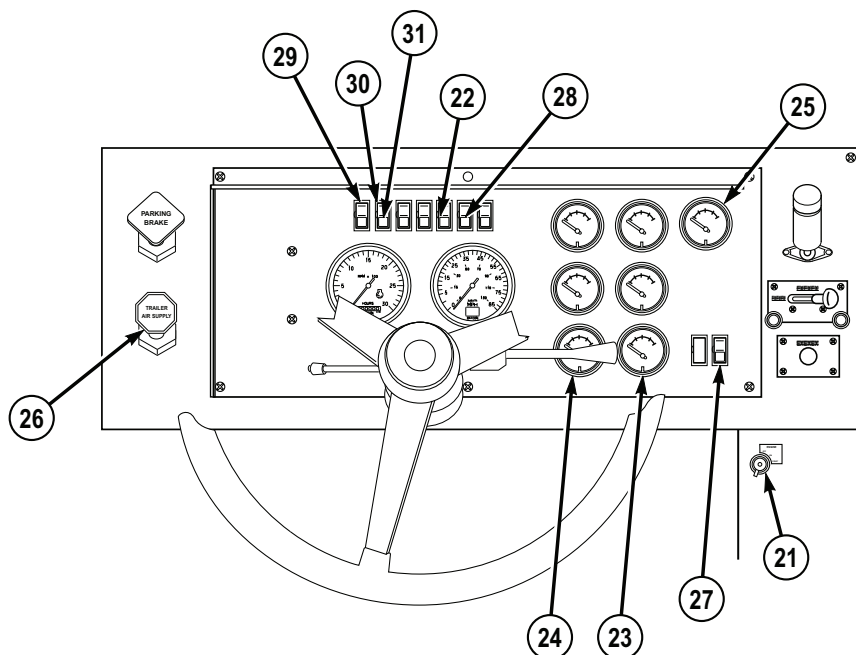

Figure 3.

21	ENGINE Switch	Three position switch. Straight up is OFF position. ON position operates electrical system. Hold switch in START position to operate engine cranking circuit. When switch is released after engine starts, switch will return to ON position.
22	LOW AIR Indicator	Illuminates (red) and remains lit until airbrake air pressure in each section of dual system is between 60 psi (414 kPa) to 75 psi (517 kPa). Buzzer will sound anytime indicator is lit.

Table 1. Instrument Panel Controls and Indicators. - Continued

Key	Control/ Indicator	Function
23	AIR PRESS Gauge	Displays air pressure (in psi and kPa) in both sections of airbrake system. Green needle shows front section air pressure. Red needle shows rear section air pressure.
24	BATTERY Gauge	Displays state of charge of batteries and alternator voltage output.
25	AMPERES Gauge	Displays alternator output in Amperes.
26	TRAILER AIR SUPPLY Control	Supplies air to (push in) and shuts off (pull out) air to trailer brake system. When TRAILER AIR SUPPLY control is applied (pushed in), vehicle PARKING BRAKE control activates/deactivates the trailer parking brakes in concert with the vehicle.
27	DIGN REQ Switch	Activates troubleshooting system used by maintenance to diagnosis engine problems.
28	OIL-WATER Indicator	Illuminates (red) when engine oil pressure is too low or when engine coolant temperature too high. Buzzer sounds at the same time.
29	LHS Indicator (M1120A2 only)	Illuminates (green) when Hydraulic Selector Switch is in AUTO, MAN H.A., or MAN M.F. positions.
30	LHS NO TRANSIT (M1120A2 only)	Illuminates (red) when LHS system is not properly stowed in transport position.

Table 1. Instrument Panel Controls and Indicators. - Continued

Key	Control/ Indicator	Function
31	LHS OVER LOAD Indicator (M1120A2 only)	Illuminates (yellow) whenever main hydraulic relief valve is opened during loading or unloading. When light illuminates, driver will be warned that LHS has reached an overload condition or that hydraulic system is lifting very near maximum capacity. OVER LOAD indicator will come on any time main relief valve is cracked open, therefore, load or unload operation may not come to a complete stop, but light will come on momentarily. This situation would indicate that system is lifting near maximum capacity. If the LHS is overloaded, the light illuminates and the system is automatically blocked out. Off-load/on-load flatrack and attempt second operation. If, during this second attempt, the LHS shuts down, stop operation and redistribute weight or reduce payload before attempting load or unload. When attempting to load/unload Forward Repair System (FRS), manual procedures must be followed or LHS overload system will shut down the LHS system.

END OF WORK PACKAGE

**OPERATOR MAINTENANCE
HEATER COMPARTMENT CONTROLS AND INDICATORS**

CONTROLS AND INDICATORS INTRODUCTION

This section displays the location and describes the use of heater compartment controls and indicators which are used in the operation of HEMTT series vehicles. Controls and indicators described in this section are the same for all vehicles, except where otherwise indicated.

LOCATION AND USE OF CONTROLS AND INDICATORS

Know the location and proper use of every control and indicator before operating HEMTT series vehicles. Separate illustrations with keys are provided for learning about heater compartment controls and indicators.

Table 1. Heater Compartment Controls and Indicators.

Key	Control/ Indicator	Function
-----	-----------------------	----------

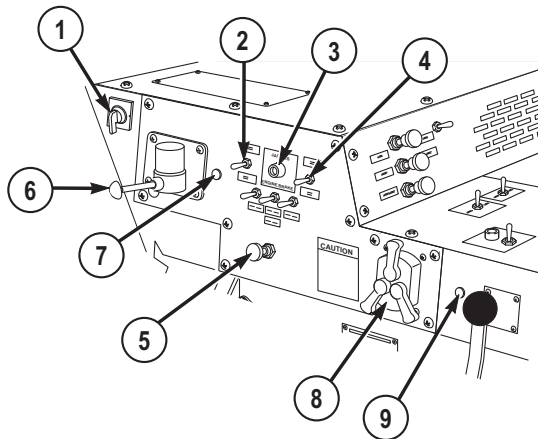

Figure 1.

1	Hydraulic Selector Switch (M1120A2 only)	OFF position: The LHS is not operational. This mode is used for transport.
---	--	--

Table 1. Heater Compartment Controls and Indicators. - Continued

Key	Control/ Indicator	Function
		AUTO position: For normal loading/unloading operations.
		MAN H.A. (Manual Hook Arm): Places the LHS in manual mode for moving the hook arm when the AUTO mode electronic circuits fail. Also used during loading/unloading operations to/from trailer or docks.
		MAN M.F. (Manual Main Frame) position: Places the LHS in manual mode for moving the main frame when the AUTO mode electronic circuits fail. Also used during loading/unloading operations to/from trailer or docks.
		MAN TRANS (Manual Transit) position: This position must be selected if vehicle is to travel after the LHS AUTO mode electronic circuit has failed and the MAN H.A. and/or MAN M.F. modes have been used.
		CRANE/SRW position: Not used on this vehicle.
2	JACOBS ® ENGINE BRAKE ON/ OFF Switch	Supplies or shuts off electrical power to JACOBS ® ENGINE BRAKE.
3	JACOBS ® ENGINE BRAKE Indicator	Illuminates (green) when JACOBS ® ENGINE BRAKE ON-OFF switch is in ON position.
4	JACOBS ® ENGINE	Selects number of engine cylinders used for engine braking action. HIGH position provides maximum braking. LOW position provides less engine braking.

Table 1. Heater Compartment Controls and Indicators. - Continued

Key	Control/ Indicator	Function
	BRAKE HIGH/ LOW Switch	
5	WIPER/ WASHER Switch	<p>Controls both wipers and washer.</p> <p>Turn switch clockwise (CW):</p> <p>1 click - Intermittent.</p> <p>2 clicks - Steady (medium) speed.</p> <p>3 clicks - Steady (fast) speed.</p> <p>Push switch in to cycle washer.</p> <p>Release switch to stop washer.</p> <p>Some early HEMTT A2 vehicles may be equipped with pneumatic windshield wiper/washer. If this is the case, there will be three control knobs instead of only one (shown) located in the same area. The individual button functions are listed below.</p> <p>Forward Button - controls operation of left side wiper.</p> <p>Middle Button - controls operation of right side wiper.</p>

Table 1. Heater Compartment Controls and Indicators. - Continued

Key	Control/ Indicator	Function
		Rear Button - controls washer.
6	Trailer Handbrake Control	Used to test the trailer brakes. Pull control lever back to apply, push forward to release trailer brakes.
7	LHS System Circuit Breaker (M1120A2 only)	Protects LHS System from electrical overload.
8	Light Control	Controls all electrical power to all parts of lighting system.
9	Auxiliary Equipment Circuit Breaker	Protects auxiliary equipment from electrical overload.

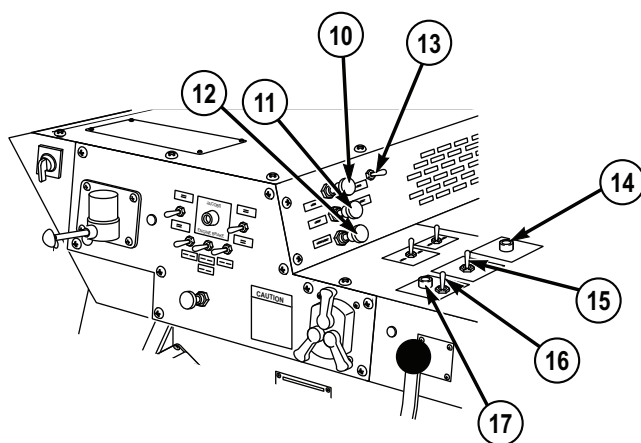

Figure 2.

Table 1. Heater Compartment Controls and Indicators. - Continued

Key	Control/ Indicator	Function
10	AIR Control	Controls amount of outside air entering cab through fresh air vent.
11	HEAT Control	Controls amount of hot air entering cab.
12	DEFROST Control	Controls amount of hot air blown on windshield.
13	FAN Control	Controls speed of heater fan.
14	CRANE OUTRIGGER EXTENDED Indicator (M985E1A2 only)	Illuminates (red) when HIAB crane outriggers are extended.
15	High Idle Switch (M1977A2 Only)	When set to ON position, increases engine speed (RPM) from low to high for operating CBT/LHS Equipment.
16	PTO ENGAGE Control	Turns electrical power to power take-off (PTO) ON/OFF.

Table 1. Heater Compartment Controls and Indicators. - Continued

Key	Control/ Indicator	Function
-----	-----------------------	----------

17	PTO ENGAGE Indicator	Illuminates (red) when PTO ENGAGE control is set to ON position.
----	----------------------	--

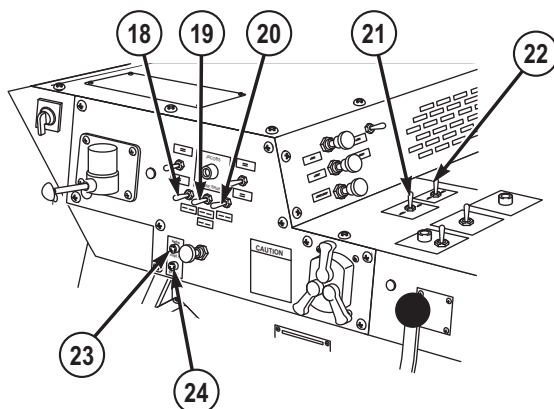

Figure 3.

18	CL LPS Switch	Light control (8) must be in STOP LIGHT or SER DRIVE position for CL LPS switch to work. Up position turns clearance lights on. Down position turns clearance lights off.
19	DOME Light Switch	Light control (8) must be in STOP LIGHT or SER DRIVE position for CL LPS switch to work. Up position turns cab dome light on. Down position turns cab dome light off.
20	WORK LIGHT Switch (M983A2, M983A2 LET, M984A2, and M1977A2 only)	Light control (8) must be in STOP LIGHT or SER DRIVE position for CL LPS switch to work. Up position turns on work lights. Down position turns work lights off.
21	GPFU Switch	Turns gas particulate filter unit (GPFU) ON/OFF.

Table 1. Heater Compartment Controls and Indicators. - Continued

Key	Control/ Indicator	Function
22	GAS ALARM Switch	Turns M-8 chemical alarm ON/OFF.
23	XMSN FUSE	Only applicable to vehicles equipped with 4500SP transmission.
24	SPARE	Only applicable to vehicles equipped with 4500SP transmission.

END OF WORK PACKAGE

OPERATOR MAINTENANCE OPERATOR AND CREW FOUR-POINT SEATBELT/AIR-RIDE SEAT ADJUSTMENT CONTROLS

CONTROLS AND INDICATORS INTRODUCTION

This section displays the location and describes the use of operator and crew four-point seatbelt/air-ride seat adjustment controls which are used in the operation of HEMTT series vehicles. Controls and indicators described in this section are the same for all vehicles, except where otherwise indicated.

LOCATION AND USE OF CONTROLS AND INDICATORS

Know the location and proper use of every control and indicator before operating HEMTT series vehicles. Separate illustrations with keys are provided for learning about operator and crew four-point seatbelt/air-ride seat adjustment controls.

Table 1. Operator and Crew Four-Point Seatbelt/Air-Ride Seat Adjustment Controls.

Key	Control/ Indicator	Function
-----	-----------------------	----------

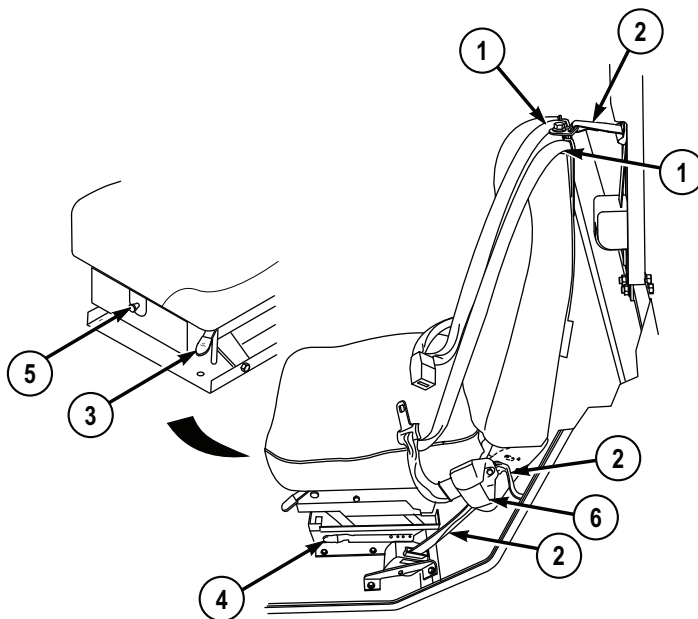

Figure 1.

Table 1. Operator and Crew Four-Point Seatbelt/Air-Ride Seat Adjustment Controls. - Continued

Key	Control/ Indicator	Function
1	Seatbelt	Secures personnel to seat.
2	Seat Connector Straps	Secures seat to cab frame.
3	Height Adjustment Control	Used to adjust seat height.
4	Forward/ Backward Adjustment Control	Used to move seat forward or backward on slides.
5	Ride Adjustment Control	Used to adjust seat tension and ride firmness.
6	Retractor	Locks seatbelt in event of accident, stows belt when not in use.

END OF WORK PACKAGE

**OPERATOR MAINTENANCE
24V BATTERY DISCONNECT SWITCH**

CONTROLS AND INDICATORS INTRODUCTION

This section displays the location and describes the use of 24V Battery Disconnect Switch which is used in the operation of HEMTT series vehicles. Controls and indicators described in this section are the same for all vehicles, except where otherwise indicated.

LOCATION AND USE OF CONTROLS AND INDICATORS

Know the location and proper use of every control and indicator before operating HEMTT series vehicles. Separate illustrations with keys are provided for learning about 24V Battery Disconnect Switch.

Table 1. 24V Battery Disconnect Switch.

Key	Control/ Indicator	Function
-----	-----------------------	----------

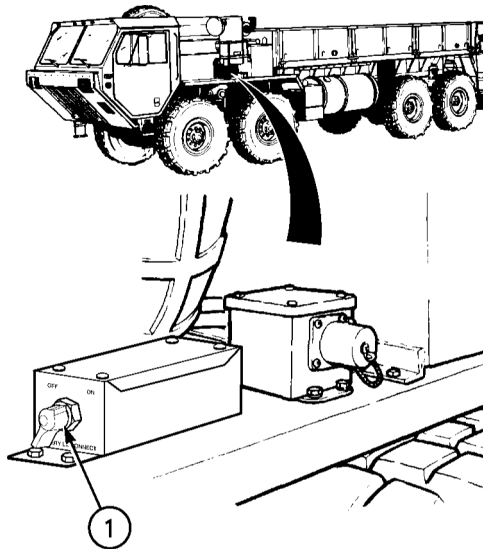

Figure 1.

Table 1. 24V Battery Disconnect Switch. - Continued

Key	Control/ Indicator	Function
1	24V BATTERY DISCONNECT Switch	When in the ON position, power is available to control modules and electrical system. When in OFF position, battery does not run down due to control module load.

END OF WORK PACKAGE

**OPERATOR MAINTENANCE
HYDRAULIC SELECTOR VALVE CONTROL**

CONTROLS AND INDICATORS INTRODUCTION

This section displays the location and describes the use of Hydraulic Selector Valve Control which are used in the operation of HEMTT series vehicles. Controls and indicators described in this section are the same for all vehicles, except where otherwise indicated.

LOCATION AND USE OF CONTROLS AND INDICATORS

Know the location and proper use of every control and indicator before operating HEMTT series vehicles. Separate illustrations with keys are provided for learning about Hydraulic Selector Valve Control.

Table 1. Hydraulic Selector Valve Control.

Key	Control/ Indicator	Function
-----	-----------------------	----------

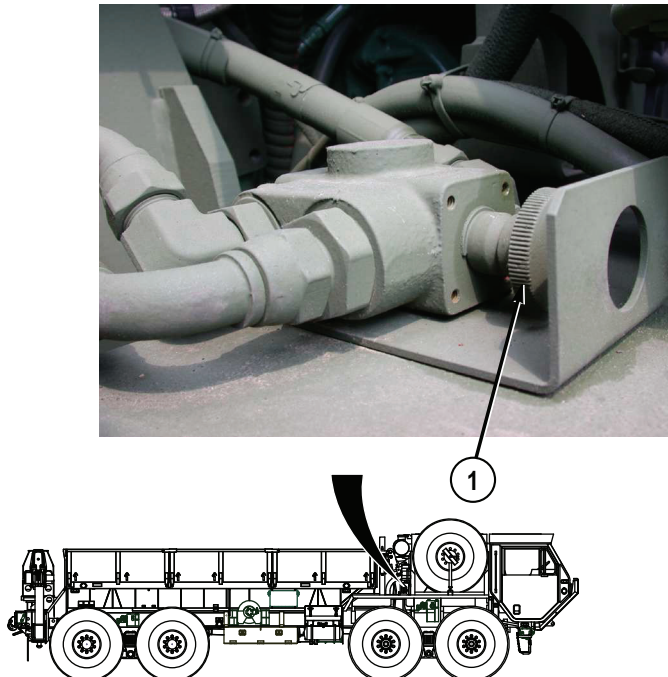

Figure 1.

Table 1. Hydraulic Selector Valve Control. - Continued

Key	Control/ Indicator	Function
1	Hydraulic Selector Valve Control	Diverts main hydraulic power to/from Self-Recovery Winch: Self-Recovery Winch operation - PULL OUT. All other operations - PUSH IN (shown).

END OF WORK PACKAGE

OPERATOR MAINTENANCE GROVE CRANE CONTROL LEVERS

CONTROLS AND INDICATORS INTRODUCTION

This section displays the location and describes the use of grove crane control levers which are used in the operation of HEMTT series vehicles. Controls and indicators described in this section are the same for all vehicles, except where otherwise indicated.

LOCATION AND USE OF CONTROLS AND INDICATORS

Know the location and proper use of every control and indicator before operating HEMTT series vehicles. Separate illustrations with keys are provided for learning about grove crane control levers.

Table 1. Grove Crane Control Levers.

Key	Control/ Indicator	Function
-----	-----------------------	----------

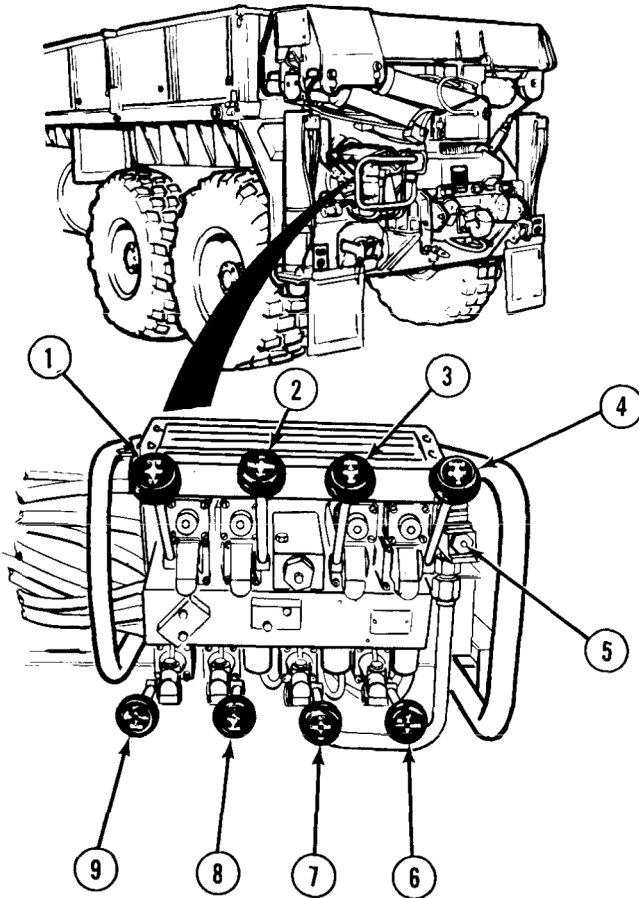

Figure 1.

- | | | |
|---|----------------------------|---|
| 1 | SWING
Control Lever | Rotates crane boom clockwise (CW) and counterclockwise (CCW). |
| 2 | TELESCOPE
Control Lever | Extends and retracts first and second stages of boom. |

Table 1. Grove Crane Control Levers. - Continued

Key	Control/ Indicator	Function
3	BOOM Control Lever	Raises and lowers boom.
4	HOIST Control Lever	Reels in and pays out hoist cable.
5	Shut-Down Solenoid Valve Button	Provides emergency hydraulic power when electrical power fails.
6	RH O/R JACK Control Lever	Lowers and raises right outrigger jack.
7	O/R EXT Control Lever	Extends and retracts outrigger beams.
8	MAST Control Lever	Raises mast to operating position and lowers mast to stowage position.
9	LH O/R JACK Control Lever	Lowers and raises left outrigger jack.

END OF WORK PACKAGE

OPERATOR MAINTENANCE GROVE CRANE BOXES AND REMOTE-CONTROL UNIT

CONTROLS AND INDICATORS INTRODUCTION

This section displays the location and describes the use of grove crane boxes and remote-control unit which is used in the operation of HEMTT series vehicles. Controls and indicators described in this section are the same for all vehicles, except where otherwise indicated.

LOCATION AND USE OF CONTROLS AND INDICATORS

Know the location and proper use of every control and indicator before operating HEMTT series vehicles. Separate illustrations with keys are provided for learning about grove crane boxes and remote-control unit.

Table 1. Grove Crane Boxes and Remote-Control Unit.

Key	Control/ Indicator	Function
1	POWER Switch	Turns crane electrical power ON/OFF.
2	REMOTE CONTROL CONNECTOR	Receptacle for connecting remote-control unit cable.
3	SWING Control Lever	Moves crane clockwise (CW) and counterclockwise (CCW).

Figure 1.

- | | | |
|---|--------------------------|--|
| 1 | POWER Switch | Turns crane electrical power ON/OFF. |
| 2 | REMOTE CONTROL CONNECTOR | Receptacle for connecting remote-control unit cable. |
| 3 | SWING Control Lever | Moves crane clockwise (CW) and counterclockwise (CCW). |

Table 1. Grove Crane Boxes and Remote-Control Unit. - Continued

Key	Control/ Indicator	Function
4	TELESCOPE Control Lever	Extends (OUT) and retracts (IN) first and second stages of boom.
5	BOOM Control Lever	Raises (UP) and lowers (DOWN) boom.
6	HOIST Control Lever	Reels in (UP) and pays out (DOWN) hoist cable.
7	REMOTE- CONTROL UNIT ON/OFF Switch	Turns remote-control unit ON/OFF.
8	ENGINE HIGH IDLE Power Switch	Turns ENGINE HIGH IDLE LATCH switch electrical power ON/OFF.
9	ENGINE HIGH IDLE LATCH Switch	Increases engine speed to high idle.

END OF WORK PACKAGE

OPERATOR MAINTENANCE RIFLE STOWAGE MOUNT

CONTROLS AND INDICATORS INTRODUCTION

This section displays the location and describes the use of Rifle Stowage Mounts which are used in the operation of HEMTT series vehicles. Controls and indicators described in this section are the same for all vehicles, except where otherwise indicated.

LOCATION AND USE OF CONTROLS AND INDICATORS

Know the location and proper use of every control and indicator before operating HEMTT series vehicles. Separate illustrations with keys are provided for learning about Rifle Stowage Mount.

Table 1. Rifle Stowage Mount.

Key	Control/ Indicator	Function
-----	-----------------------	----------

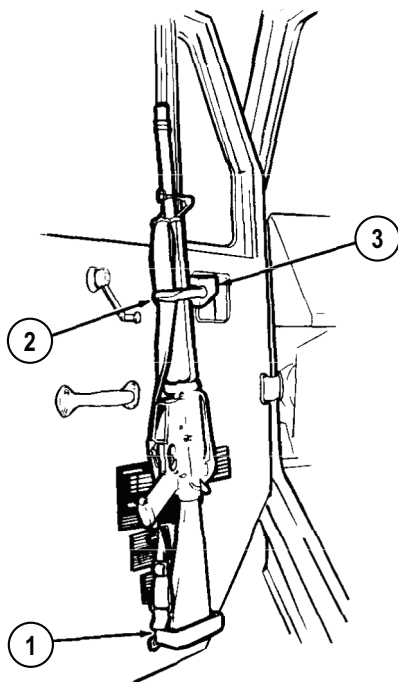
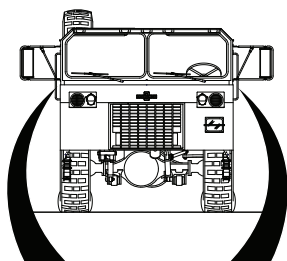

Figure 1.

1	Lower Rifle Mount	Holds butt of rifle.
---	-------------------	----------------------

Table 1. Rifle Stowage Mount. - Continued

Key	Control/ Indicator	Function
2	Rifle Mount Handle	Secures heat guard of rifle against top rifle mount.
3	Top Rifle Mount	Holds heat guard of rifle.

END OF WORK PACKAGE

**OPERATOR MAINTENANCE
ARCTIC ENGINE HEATER CONTROLS AND INDICATORS**

CONTROLS AND INDICATORS INTRODUCTION

This section displays the location and describes the use of Arctic Engine Heater controls and indicators (optional accessory) which are used in the operation of HEMTT series vehicles. Controls and indicators described in this section are the same for all vehicles, except where otherwise indicated.

LOCATION AND USE OF CONTROLS AND INDICATORS

Know the location and proper use of every control and indicator before operating HEMTT series vehicles. Separate illustrations with keys are provided for learning about Arctic Engine Heater controls and indicators (optional accessory).

Table 1. Arctic Engine Heater Controls And Indicators.

Key	Control/ Indicator	Function
		

Figure 1.

Table 1. Arctic Engine Heater Controls And Indicators. - Continued

Key	Control/ Indicator	Function
1	ON/OFF Switch	Two position switch starts operation of arctic engine heater.
2	Arctic Engine Heater Light Indicator	Light illuminates when arctic engine heater switch is placed in ON position. If light does not illuminate or if light flashes intermittently, arctic engine heater is malfunctioning.

END OF WORK PACKAGE

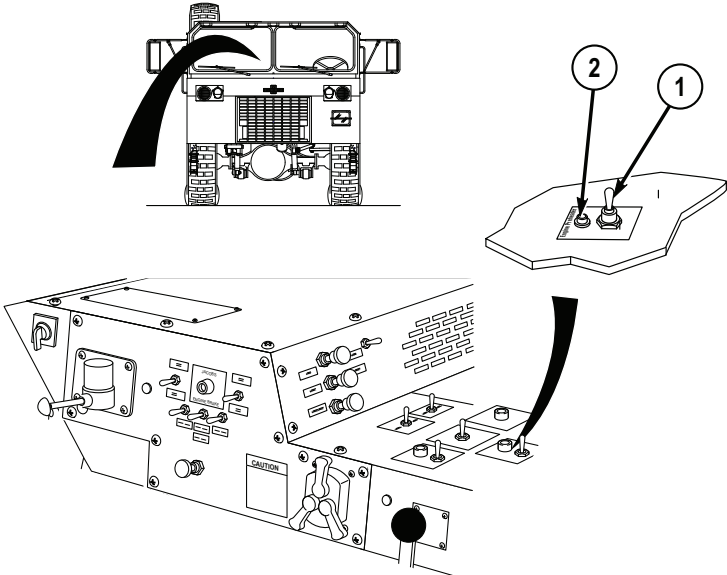
**OPERATOR MAINTENANCE
GAS PARTICULATE FILTER UNIT (GPFU) CONTROLS AND INDICATORS**

CONTROLS AND INDICATORS INTRODUCTION

This section displays the location and describes the use of Gas Particulate Filter Unit (GPFU) controls and indicators which is used in the operation of HEMTT series vehicles. Controls and indicators described in this section are the same for all vehicles, except where otherwise indicated.

LOCATION AND USE OF CONTROLS AND INDICATORS

Know the location and proper use of every control and indicator before operating HEMTT series vehicles. Separate illustrations with keys are provided for learning about Gas Particulate Filter Unit (GPFU) controls and indicators.

Table 1. Gas Particulate Filter Unit (GPFU) Controls And Indicators.

Key	Control/ Indicator	Function
-----	-----------------------	----------

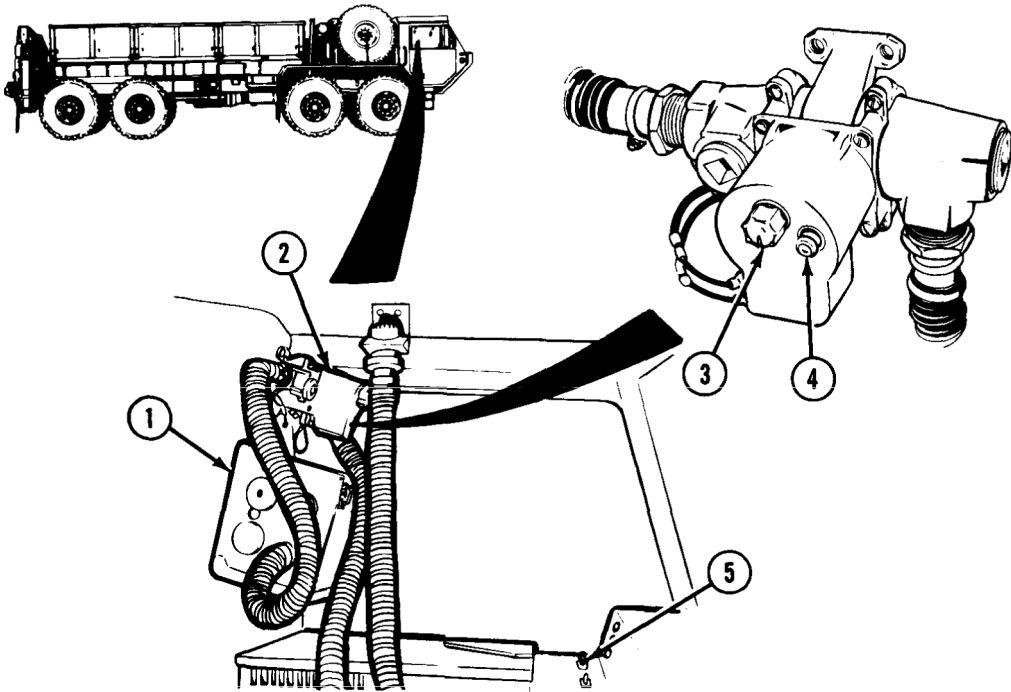

Figure 1.

1	Gas Particulate Filter	Filters nuclear, biological, and chemical (NBC) contaminants from air.
2	M-3 Heater	Warms air entering protective mask.
3	M-3 Heater Control Knob	Turn clockwise (CW) for warmer air turn counterclockwise (CCW) for cooler air. Turn to OFF to shut off heater.
4	M-3 Heater Indicator Light	Illuminates when heater is operating.

Table 1. Gas Particulate Filter Unit (GPFU) Controls And Indicators. - Continued

Key	Control/ Indicator	Function
5	GAS PARTICULAT E FILTER UNIT Switch	Turns GPFU ON/OFF.

END OF WORK PACKAGE

OPERATOR MAINTENANCE MACHINE GUN MOUNT

CONTROLS AND INDICATORS INTRODUCTION

This section displays the location and describes the use of Machine Gun Mount (Optional Accessory) which is used in the operation of HEMTT series vehicles. Controls and indicators described in this section are the same for all vehicles, except where otherwise indicated.

LOCATION AND USE OF CONTROLS AND INDICATORS

Know the location and proper use of every control and indicator before operating HEMTT series vehicles. Separate illustrations with keys are provided for learning about Machine Gun Mount (Optional Accessory).

Table 1. Machine Gun Mount.

Key	Control/ Indicator	Function
-----	-----------------------	----------

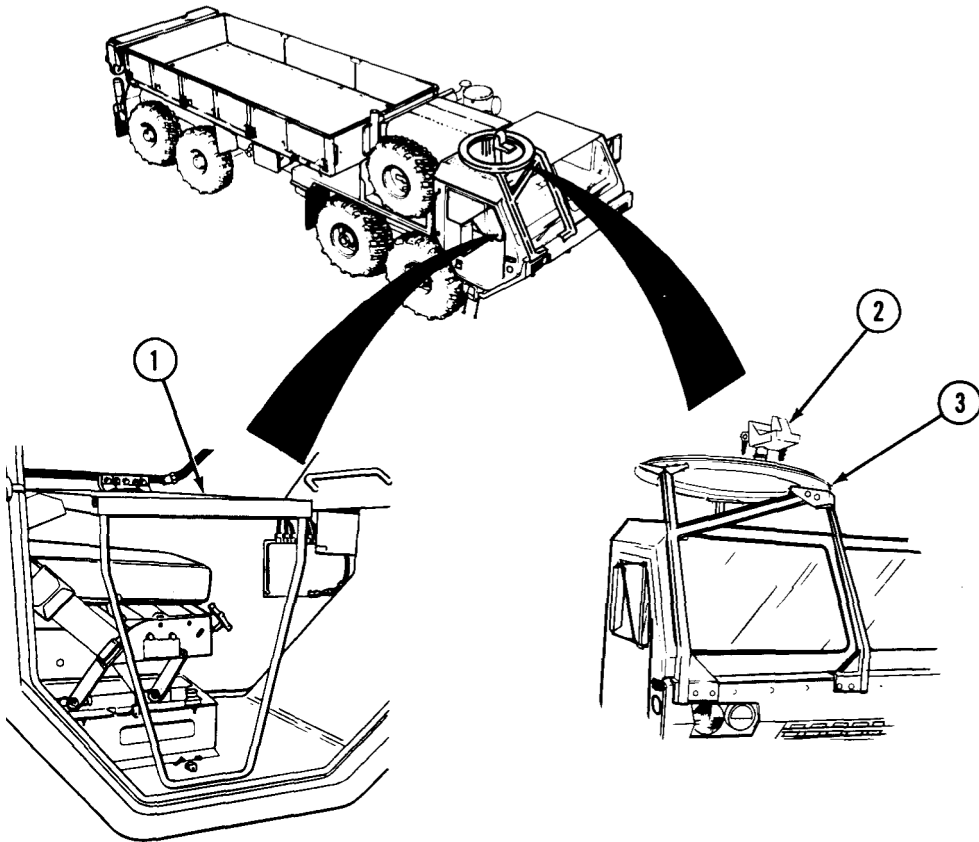

Figure 1.

1	Machine Gun Mount	Secures machine gun to machine gun ring.
2	Machine Gun Ring	Allows machine gun to turn 360 degrees.

END OF WORK PACKAGE

**OPERATOR MAINTENANCE
M-8 CHEMICAL ALARM CONTROLS AND INDICATORS**

CONTROLS AND INDICATORS INTRODUCTION

This section displays the location and describes the use of M-8 Chemical Alarm controls and indicators which are used in the operation of HEMTT series vehicles. Controls and indicators described in this section are the same for all vehicles, except where otherwise indicated.

LOCATION AND USE OF CONTROLS AND INDICATORS

Know the location and proper use of every control and indicator before operating HEMTT series vehicles. Separate illustrations with keys are provided for learning about M-8 Chemical Alarm controls and indicators.

Table 1. M-8 Chemical Alarm Controls And Indicators.

Key	Control/ Indicator	Function
-----	-----------------------	----------

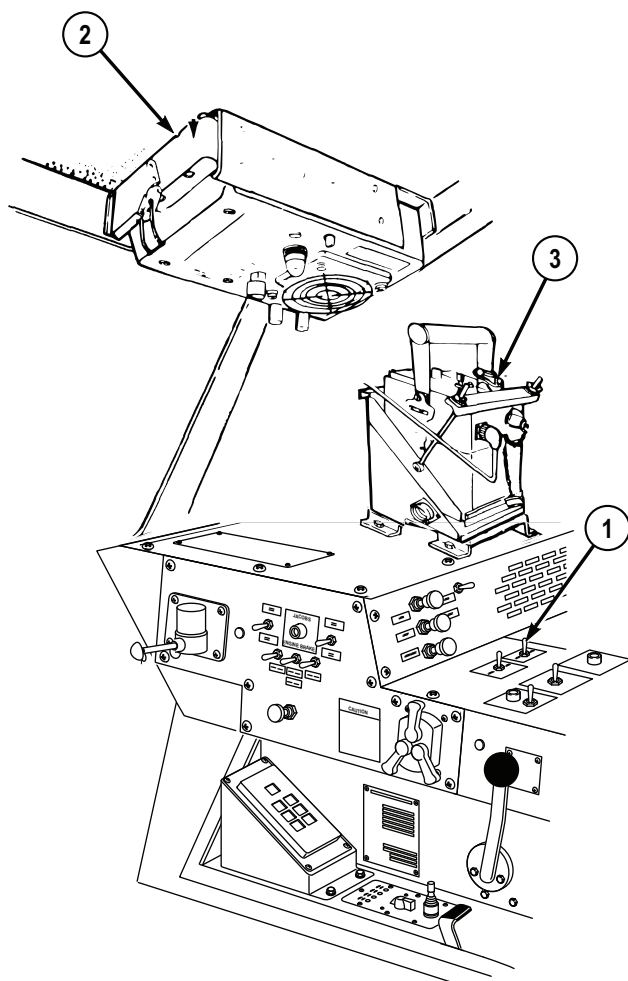

Figure 1.

1	M-8 Chemical Alarm Switch	Operates alarm.
---	---------------------------	-----------------

Table 1. M-8 Chemical Alarm Controls And Indicators. - Continued

Key	Control/ Indicator	Function
2	M-8 Chemical Alarm	Sounds alarm when chemicals are detected.
3	Chemical Detector	Detects presence of chemical in the air.

END OF WORK PACKAGE

OPERATOR MAINTENANCE M-13 DECONTAMINATION KIT

CONTROLS AND INDICATORS INTRODUCTION

This section displays the location and describes the use of M-13 Decontamination Kit which is used in the operation of HEMTT series vehicles. Controls and indicators described in this section are the same for all vehicles, except where otherwise indicated.

LOCATION AND USE OF CONTROLS AND INDICATORS

Know the location and proper use of every control and indicator before operating HEMTT series vehicles. Separate illustrations with keys are provided for learning about M-13 Decontamination Kit.

Table 1. M-13 Decontamination Kit.

Key	Control/ Indicator	Function
-----	-----------------------	----------

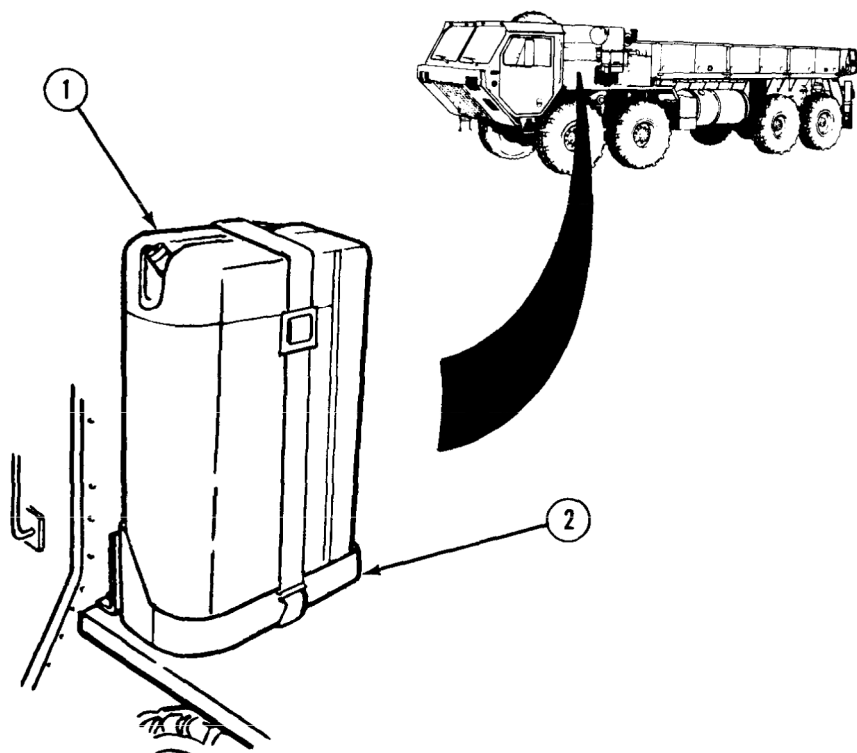

Figure 1.

- | | | |
|---|---------------------------------|------------------------------------|
| 1 | M-13
Decontamination
Unit | Holds and dispenses decontaminant. |
| 2 | Decontamination
Unit Mount | Holds decontamination unit. |

END OF WORK PACKAGE

OPERATOR MAINTENANCE RADIO INSTALLATION HARDWARE

CONTROLS AND INDICATORS INTRODUCTION

This section displays the location and describes the use of radio installation hardware which is used in the operation of HEMTT series vehicles. Controls and indicators described in this section are the same for all vehicles, except where otherwise indicated.

LOCATION AND USE OF CONTROLS AND INDICATORS

Know the location and proper use of every control and indicator before operating HEMTT series vehicles. Separate illustrations with keys are provided for learning about radio installation hardware.

Table 1. Radio Installation Hardware.

Key	Control/ Indicator	Function
-----	-----------------------	----------

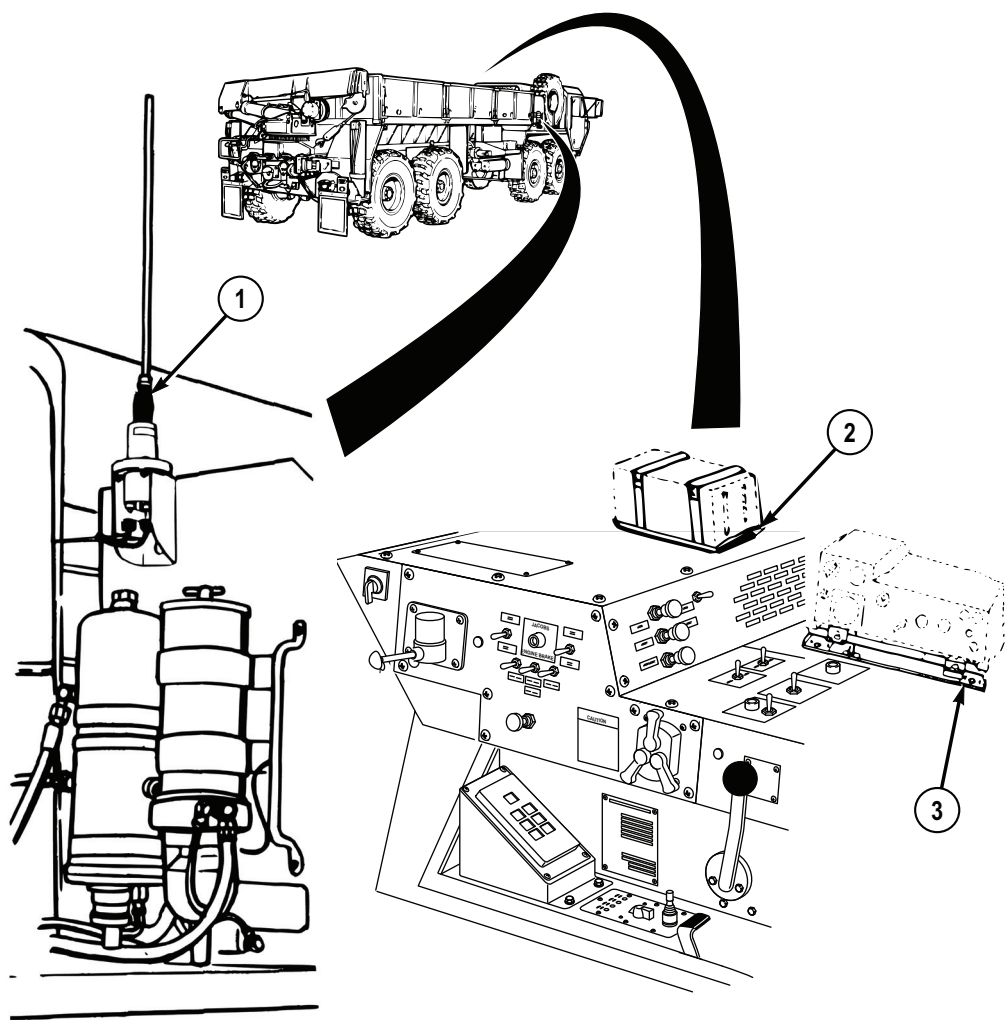

Figure 1.

1	Antenna Matching Unit	Holds antenna.
---	--------------------------	----------------

Table 1. Radio Installation Hardware. - Continued

Key	Control/ Indicator	Function
2	Security Unit Mount	Holds security unit.
3	Receiver/ Transmitter Mount	Holds receiver/transmitter.

END OF WORK PACKAGE

**OPERATOR MAINTENANCE
OPERATE WINDSHIELD WIPERS/WASHER**

INITIAL SETUP:

Not Applicable

OPERATE WINDSHIELD WIPERS (24V)

NOTE

- Some earlier vehicles may be equipped with air driven windshield wipers (refer to operate windshield wipers (air) below for operating procedures).
- ENGINE switch must be positioned to ON for windshield wipers to operate.
- 24V battery disconnect switch must be positioned to ON (WP 0079) to operate windshield wipers.

NOTE

When WIPER/WASHER control is in the intermittent position, wipers will cycle at a faster rate the farther the control is rotated clockwise.

1. Rotate WIPER/WASHER control (1) clockwise to first position to operate wipers in intermittent.

OPERATE WINDSHIELD WIPERS (24V) - Continued

Figure 1.

2. Rotate WIPER/WASHER control (1) clockwise to second position to operate wipers at LOW speed.
3. Rotate WIPER/WASHER control (1) clockwise to third position to operate wipers at HIGH speed.
4. Rotate WIPER/WASHER control (1) completely counterclockwise to stop wipers.

OPERATE WINDSHIELD WIPERS ON/OFF (AIR)**NOTE**

- Later model vehicles are equipped with 24V driven windshield wipers (refer to operate windshield wipers (24V) above for operating procedures).
 - ENGINE switch must be positioned to ON for windshield wipers to operate.
 - 24V battery disconnect switch must be positioned to ON (WP 0079) to operate windshield wipers.
1. Turn WIPER control (1) clockwise to start and control speed of driver side windshield wiper.

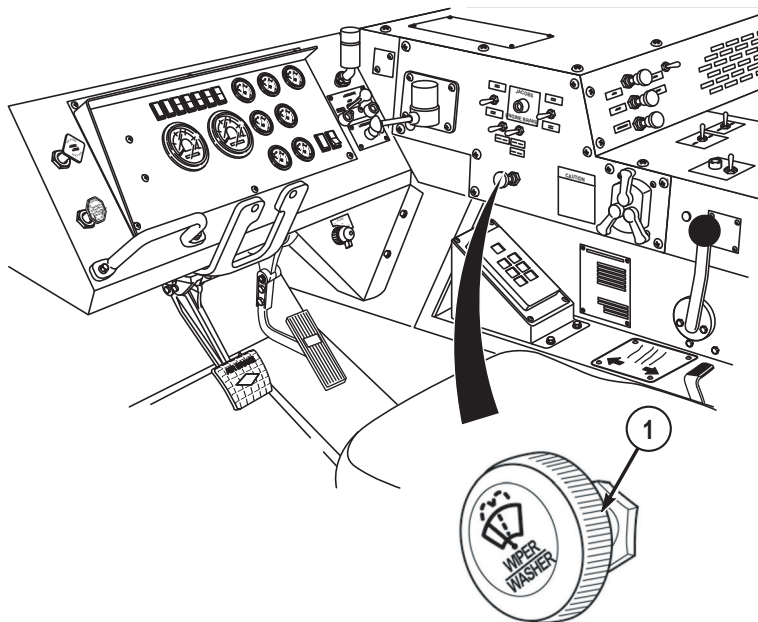
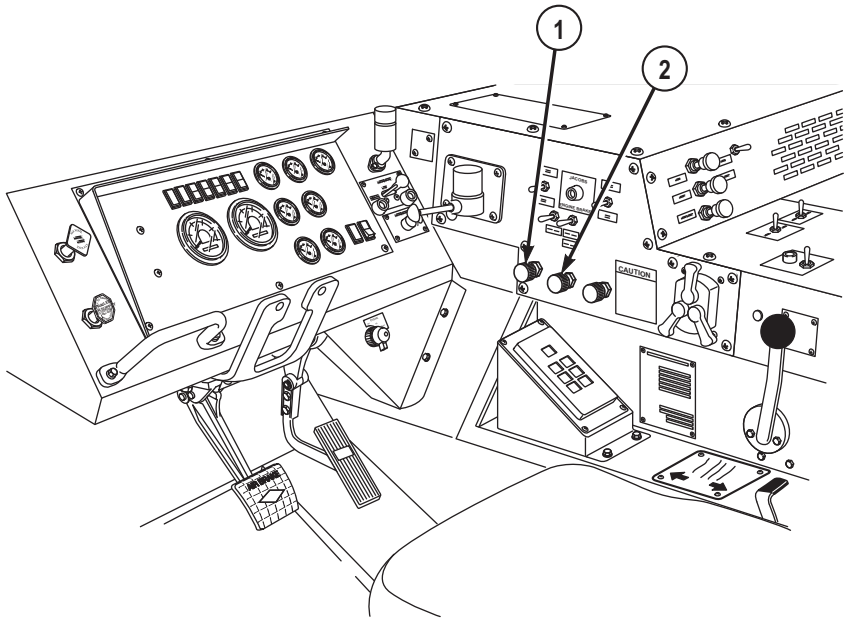
OPERATE WINDSHIELD WIPERS ON/OFF (AIR) - Continued*Figure 2.*

2. Turn WIPER control (2) clockwise to start and control speed of passenger side windshield wiper.
3. Turn WIPER control (1) counterclockwise to stop driver side windshield wiper.
4. Turn WIPER control (2) counterclockwise to stop passenger side windshield wiper.
5. If wiper stops in middle of windshield:
 - a. Turn appropriate WIPER control (1 or 2) clockwise until wiper is at bottom of windshield.
 - b. Turn appropriate WIPER control (1 or 2) counterclockwise to stop wiper.

OPERATE WINDSHIELD WASHER (24V)**NOTE**

- Some earlier vehicles may be equipped with air driven windshield washer (refer to operate windshield washer (air) below for operating procedures).
- 24V battery disconnect switch must be positioned to ON (WP 0079) to operate windshield washer.

OPERATE WINDSHIELD WASHER (24V) - Continued

- ENGINE switch must be positioned to ON for windshield washer to operate.

1. Push in and hold WIPER/WASHER control (1) to spray cleaning fluid on windshield.

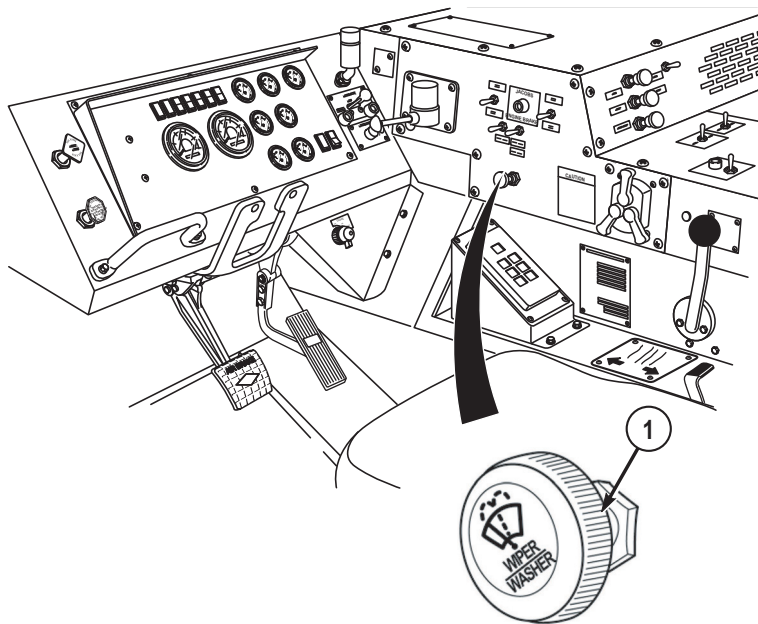

Figure 3.

2. Release WIPER/WASHER control (1) to stop spray.

OPERATE WINDSHIELD WASHER (AIR)**NOTE**

- Later model vehicles are equipped with 24V driven windshield washer (refer to operate windshield washer (24V) above for operating procedures).
- 24V battery disconnect switch must be positioned to ON (WP 0079) to operate windshield washer.
- ENGINE switch must be positioned to ON for windshield washer to operate.

1. Push in and hold WASH control (1) to spray cleaning fluid on windshield.

OPERATE WINDSHIELD WASHER (AIR) - Continued

Figure 4.

2. Release WASH control (1) to stop washer spray.

END OF TASK

END OF WORK PACKAGE

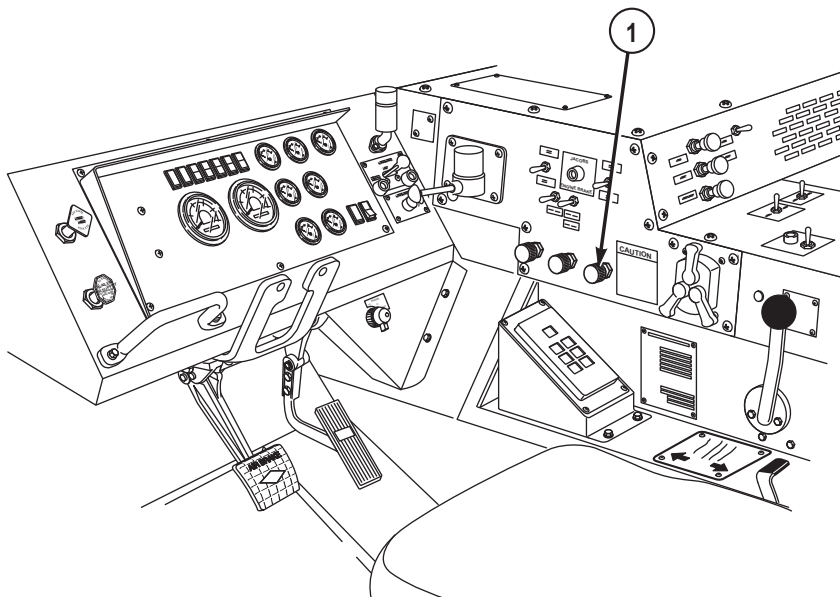
**OPERATOR MAINTENANCE
OPERATE CAB TEMPERATURE CONTROLS**

INITIAL SETUP:

Not Applicable

OPERATE PERSONNEL HEATER

NOTE

- If heater does not blow hot air, ensure heater valves are open.
 - Air temperature is controlled by position of HEAT control.
 - Pull HEAT control out to increase temperature.
 - Push HEAT control in to decrease temperature.
1. Pull out HEAT control (1) to desired position.
 2. Set FAN switch (2) to LO or HI airflow.

OPERATE PERSONNEL HEATER - Continued

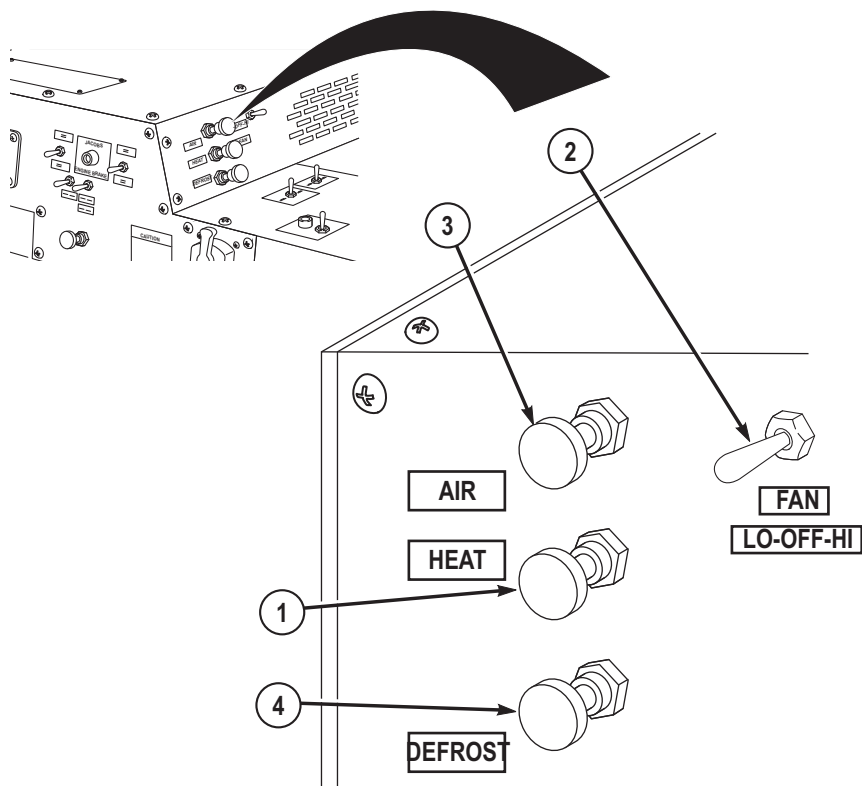
*Figure 1.***NOTE**

On later model vehicles, the AIR control has a "TURN TO LOCK" function which holds the vent open at the desired level when the control is rotated clockwise. Rotate control CCW until it stops to unlock the vent.

3. Adjust AIR control (3) as desired to control outside airflow for cab ventilation. Unlock, and push AIR control (3) all the way in to shut outside air ventilation off.
4. When personnel heater is no longer required:
 - a. Push in HEAT control (1) to turn heater off.
 - b. Set FAN switch (2) to OFF.

OPERATE WINDSHIELD DEFROST**NOTE**

If windshield defrost does not blow hot air, ensure heater valves are open.

1. Pull out DEFROST control (4) to turn on.

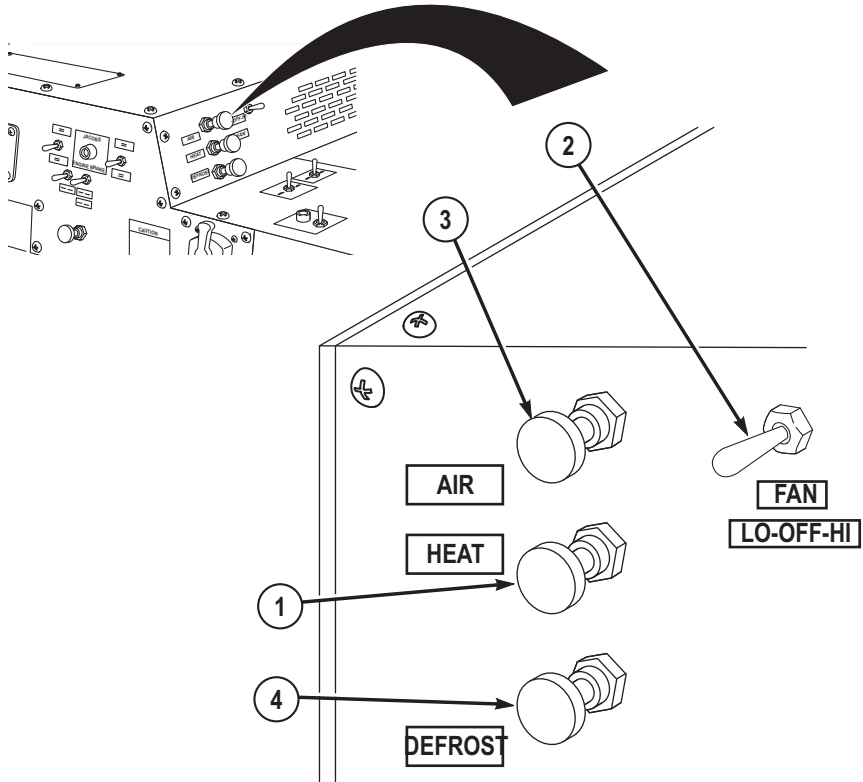

Figure 2.

2. Pull out HEAT control (1) to desired position.
3. Set FAN switch (2) to desired position.
4. When defrost is no longer required:
 - a. Push in DEFROST control (4) to turn off.
 - b. Push in HEAT control (1) to turn heater off.

OPERATE WINDSHIELD DEFROST - Continued

- c. Set FAN switch (2) to OFF.

END OF TASK

END OF WORK PACKAGE

**OPERATOR MAINTENANCE
OPERATE FIRE EXTINGUISHER**

INITIAL SETUP:

Not Applicable

REMOVE FIRE EXTINGUISHER FROM CAB

NOTE

Fire extinguisher is located on rear bulkhead on inside of cab, just inboard of driver's seat.

1. Pull up top clamp (1) and disengage from top hook (2).

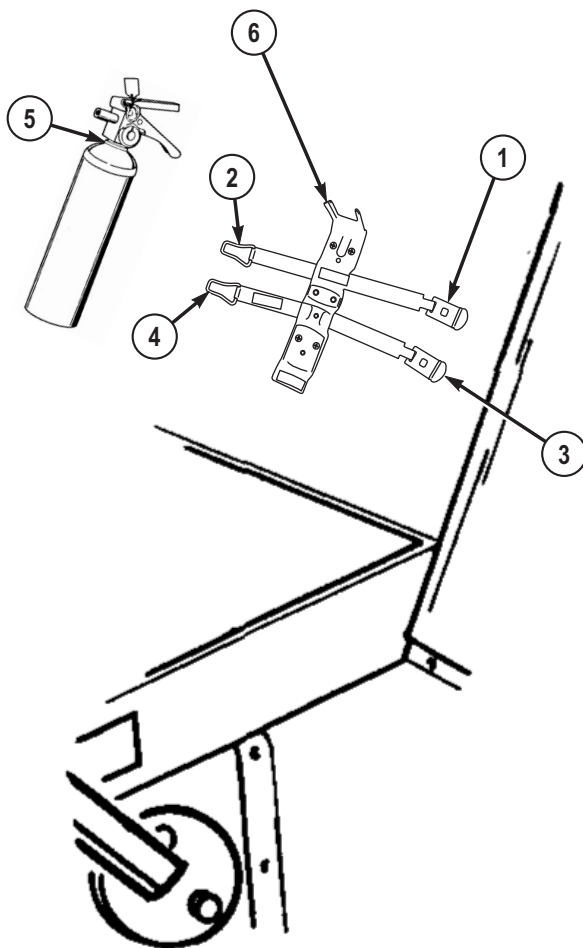
REMOVE FIRE EXTINGUISHER FROM CAB - Continued*Figure 1.*

2. Pull up bottom clamp (3) and disengage from bottom hook (4).
3. Remove fire extinguisher (5) from bracket (6).

EXTINGUISH FIRE**NOTE**

- Fire extinguisher is a dry chemical type. Refer to MSDS for specific extinguisher warnings and cautions for use.
- Remember the word "PASS" to operate fire extinguisher:

EXTINGUISH FIRE - Continued

1. Hold fire extinguisher (1) upright and pull safety pin (2) to break plastic tie (3).

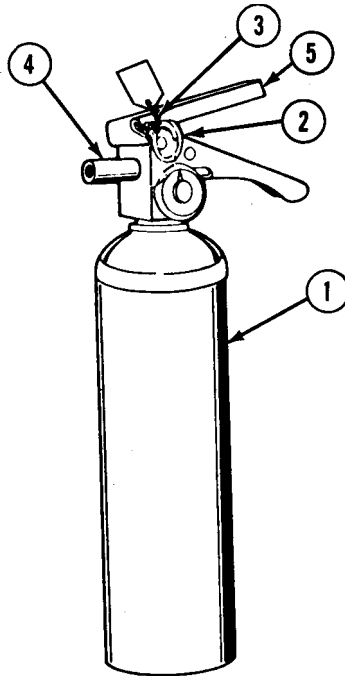

Figure 2.

2. Point nozzle (4) at base of fire.
3. Press down on stop lever (5) and spray discharge in a side-to-side motion at base of fire.
4. Let go of stop lever (5) when fire is out.
5. Notify field level maintenance to replace fire extinguisher.

INSTALL FIRE EXTINGUISHER IN CAB

1. Put neck of fire extinguisher (1) on bracket (2).

INSTALL FIRE EXTINGUISHER IN CAB - Continued

Figure 3.

2. Hook top clamp (3) on top hook (4) and push top clamp (3) down, tightening strap.
3. Hook bottom clamp (5) on bottom hook (6) and push bottom clamp (5) down, tightening strap.

END OF TASK

END OF WORK PACKAGE

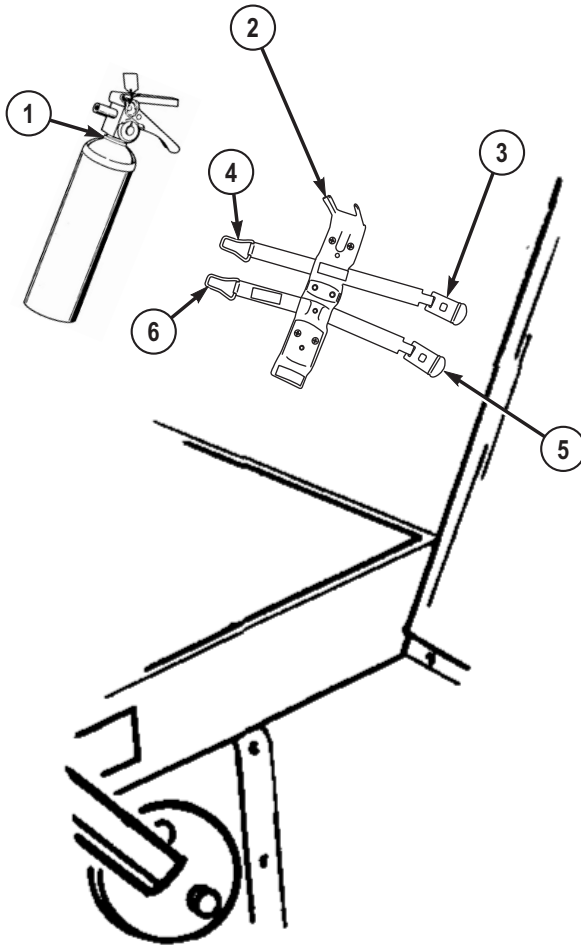
**OPERATOR MAINTENANCE
OPERATE ACCESS LADDER**

INITIAL SETUP:

Not Applicable

INSTALL ACCESS LADDER

1. Unhook two springs (1) from stowage rods (2).

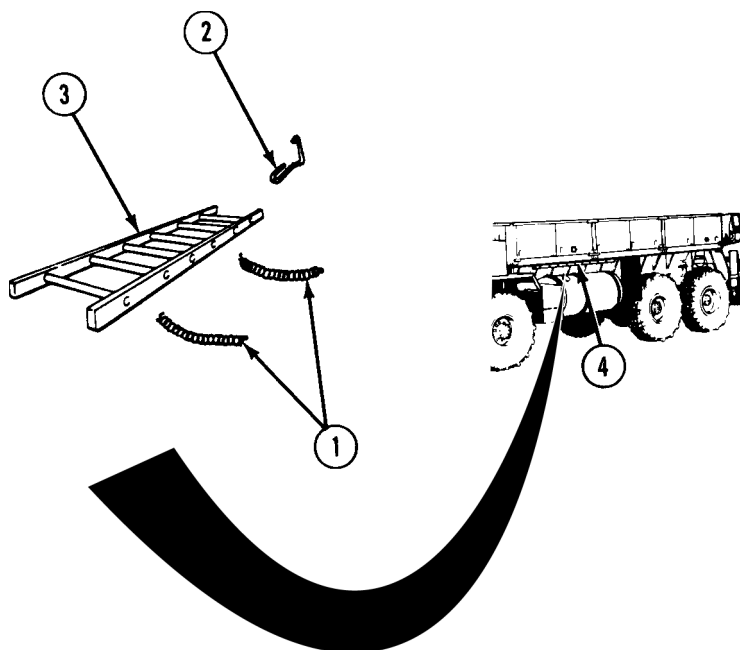

Figure 1.

2. Remove access ladder (3) from under cargo body (4).

CAUTION

Do not hit fuel/water separator when installing access ladder on passenger side front fender. If access ladder hooks hit fuel/water separator, glass may break.

INSTALL ACCESS LADDER - Continued

3. Install access ladder (3) hooks (5) in front skid plate holes (6), driver side front fender holes (7), or passenger side front fender holes (8), as required. Keep access ladder (3) clear of fuel/water separator (9).

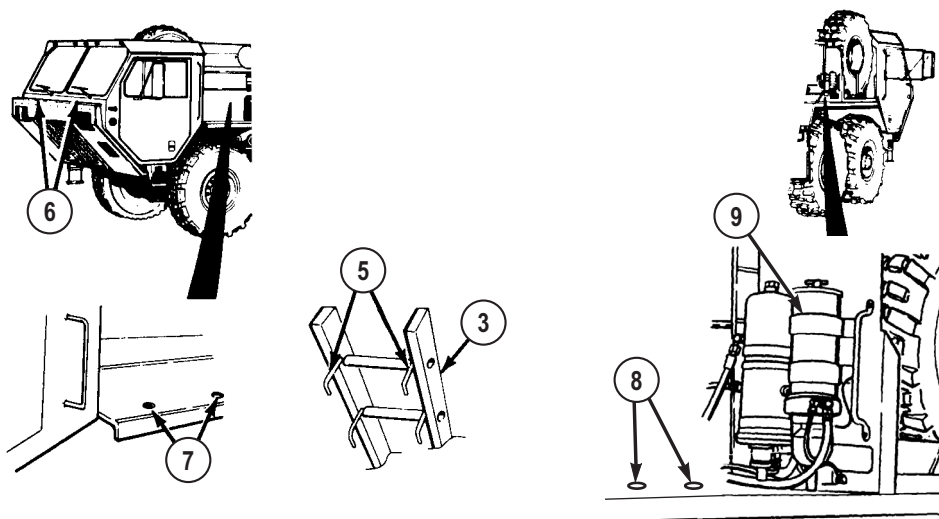
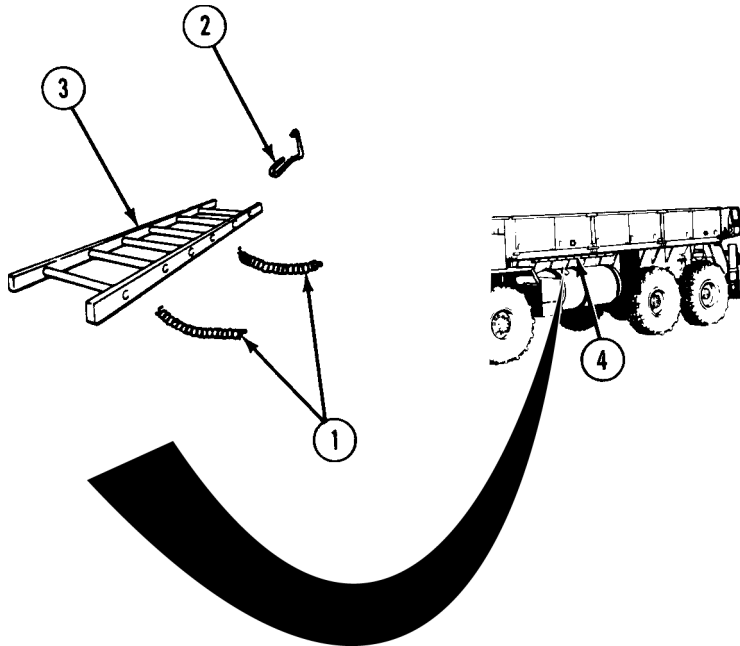

Figure 2.

STOW ACCESS LADDER

1. Hook springs (1) on stowage rods (2).

STOW ACCESS LADDER - Continued*Figure 3.*

2. Secure access ladder (3) under cargo body (4) with two springs (1) and stowage rods (2).

END OF TASK**END OF WORK PACKAGE**

**OPERATOR MAINTENANCE
OPERATE DRAIN PLUG**

INITIAL SETUP:

Not Applicable

REMOVE DRAIN PLUG**NOTE**

There are two drain plugs. One located on each side of cab floor, just below operator/crew seats.

1. Pull up on lever (1).

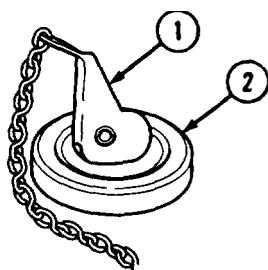

Figure 1.

2. Remove drain plug (2) to drain any liquid from floor of cab.

INSTALL DRAIN PLUG

1. Push drain plug (2) in opening on cab floor.

INSTALL DRAIN PLUG - Continued

Figure 2.

2. Press down on lever (1) to secure drain plug (2).

END OF TASK

END OF WORK PACKAGE

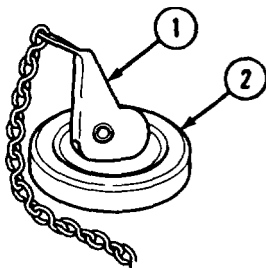
OPERATOR MAINTENANCE CONNECT/DISCONNECT TRAILER

INITIAL SETUP:

Personnel Required

Operator and Assistant(s) - - - (3)

CONNECT TRAILER (VEHICLES EQUIPPED WITH PINTLE HOOK)

NOTE

- This procedure is a three soldier task.
 - HEMTT series vehicles pull M105, M332, M989, and M1076 trailers. For more information on trailer hookup and towing procedures, refer to the following manuals:
 - M105 Trailer - TM 9-2330-213-14&P. (WP 0161)
 - M332 Trailer - TM 9-2330-231-14&P. (WP 0161)
 - M989 Trailer - TM 9-2330-385-14. (WP 0161)
 - M1076 Trailer - TM 9-2330-385-14. (WP 0161)
1. Park vehicle. (WP 0056)
 2. Shut off engine. (WP 0057)
 3. Remove cotter pin (1).

CONNECT TRAILER (VEHICLES EQUIPPED WITH PINTLE HOOK) - Continued

Figure 1.

4. Pull latch (2) away from vehicle and hold.
5. Lift top part of pintle hook (3) and let go of latch (2); hook will be locked open.
6. Put trailer connecting eye (4) on bottom part of pintle hook (5).

CONNECT TRAILER (VEHICLES EQUIPPED WITH PINTLE HOOK) - Continued*Figure 2.*

7. Pull latch (2) away from vehicle to free top part of pintle hook (3).
8. Install cotter pin (1).

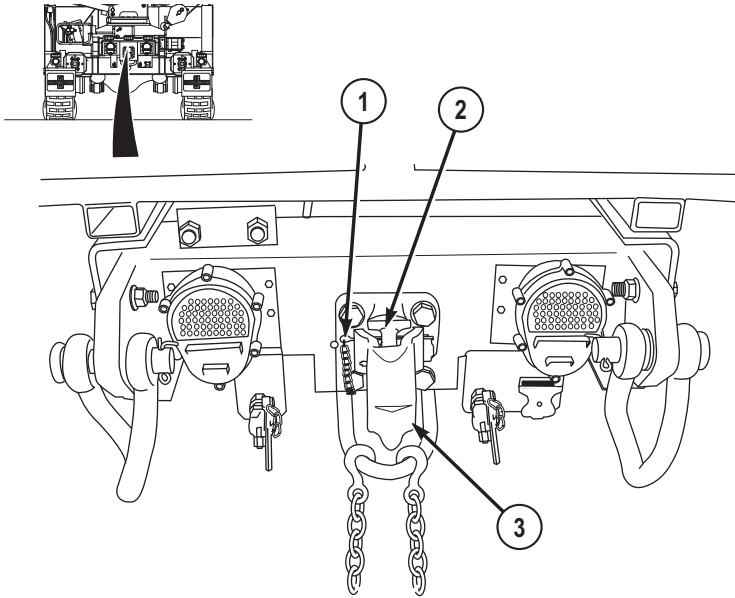
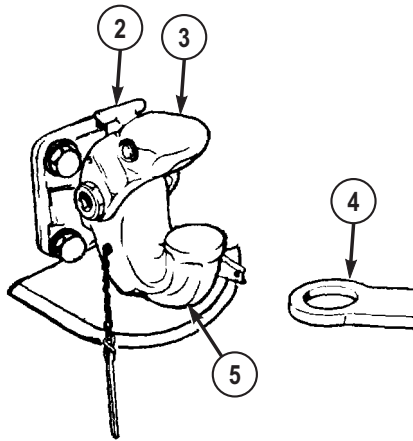
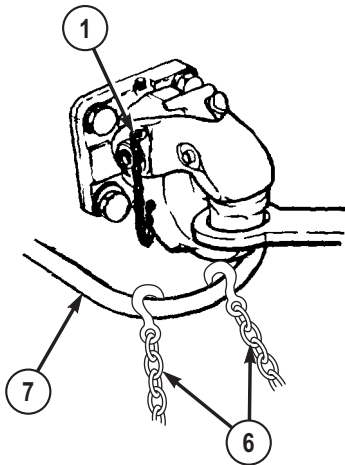
*Figure 3.*

9. Connect two safety chains (6) to safety chain hoop (7).
10. Lift cover (8) and connect inter-vehicular wiring harness (9) to connector on vehicle (10), and trailer.

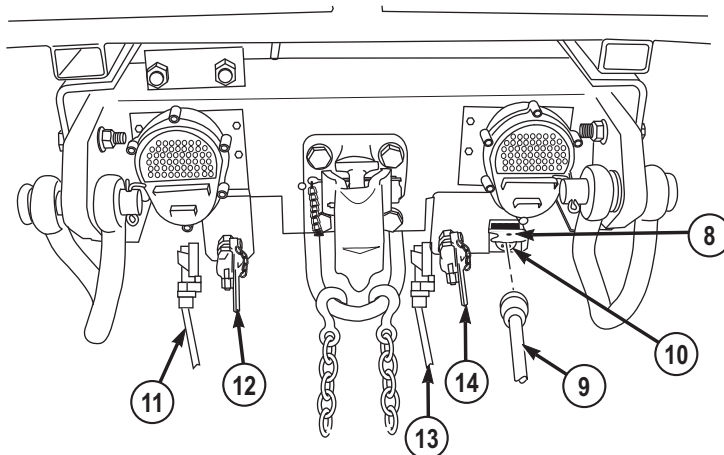
CONNECT TRAILER (VEHICLES EQUIPPED WITH PINTLE HOOK) - Continued

**TRAILER DRAWBAR
SHOWN REMOVED FOR CLARITY**

Figure 4.

11. Connect emergency (red) air line (11) to emergency (red) gladhand (12) on driver side of vehicle.
12. Connect free end of emergency (red) air line (11) to emergency (red) gladhand on driver side of trailer.
13. Connect service (blue) air line (13) to service (blue) gladhand (14) on passenger side of vehicle.
14. Connect free end of service (blue) air line (13) to service (blue) gladhand on passenger side of trailer.

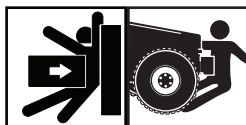
WARNING

When charging trailer air system, apply service brake pedal or install wheel chocks on vehicle. Failure to comply could result in vehicle/trailer movement which may result in injury or death to personnel.

NOTE

Dashboard parking brake indicator will go out when PARKING BRAKE control is released.

CONNECT TRAILER (VEHICLES EQUIPPED WITH PINTLE HOOK) - Continued

15. Push in PARKING BRAKE control (15).

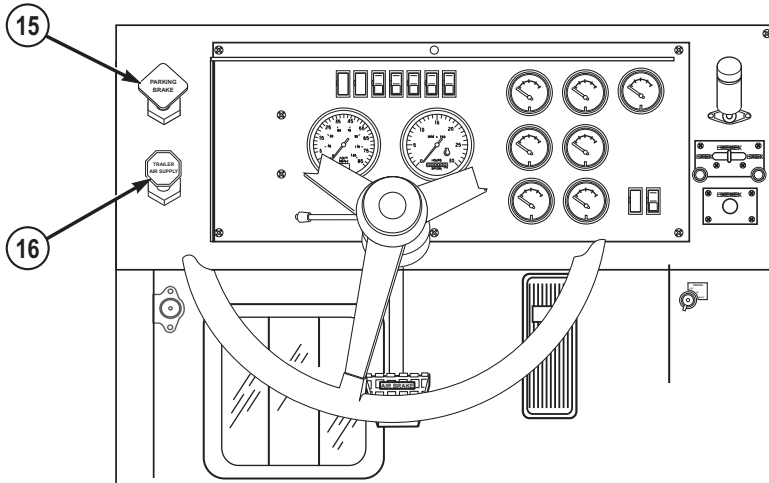

Figure 5.

16. Push in TRAILER AIR SUPPLY control (16) to charge trailer air system.

NOTE

Dashboard parking brake indicator will illuminate when PARKING BRAKE control is applied.

17. Pull out PARKING BRAKE control (15) once trailer air supply system is charged.

DISCONNECT TRAILER (VEHICLES EQUIPPED WITH PINTLE HOOK)**NOTE**

This procedure is a three soldier task.

1. Park vehicle. (WP 0056)
2. Shut off engine. (WP 0057)
3. Remove emergency (red) air line (1) from emergency (red) gladhand (2) on driver side of vehicle and emergency (red) gladhand on driver side of trailer.

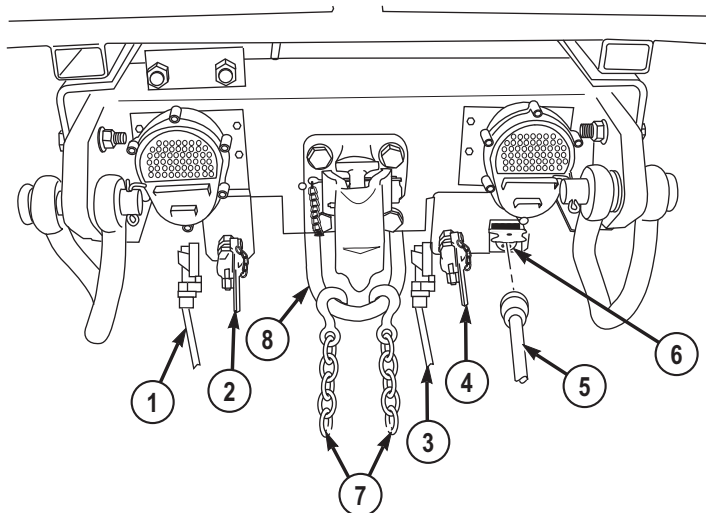
DISCONNECT TRAILER (VEHICLES EQUIPPED WITH PINTLE HOOK) - Continued

**TRAILER DRAWBAR
SHOWN REMOVED FOR CLARITY**

Figure 6.

4. Remove service (blue) air line (3) from service (blue) gladhand (4) on passenger side of vehicle and service (blue) gladhand on passenger side of trailer.
5. Remove inter-vehicular wiring harness (5) from connector (6) on vehicle.
6. Remove inter-vehicular wiring harness (5) from trailer and return to vehicle stowage.
7. Remove two safety chains (7) from safety chain hoop (8).
8. Remove cotter pin (9).

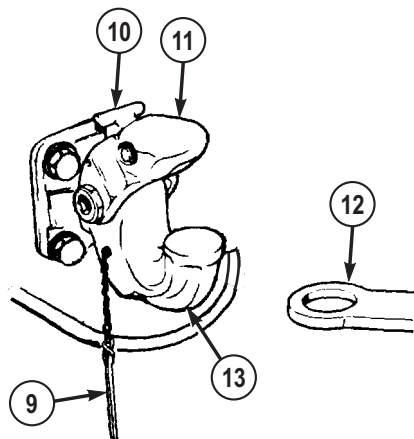
DISCONNECT TRAILER (VEHICLES EQUIPPED WITH PINTLE HOOK) - Continued*Figure 7.*

9. Pull latch (10) away from vehicle and hold.
10. Lift top part of pintle hook (11) and let go of latch (10); hook will be locked open.
11. Lift trailer connecting eye (12) off bottom of pintle hook (13).
12. Pull latch (10) away from top part of pintle hook (11).
13. Install cotter pin (9).

END OF TASK**END OF WORK PACKAGE**

**OPERATOR MAINTENANCE
CARGO BODY OPERATION**

INITIAL SETUP:**Personnel Required**Operator and Assistant - - - (2)

LOWER CARGO BODY SIDE PANELS ONE AT A TIME**WARNING**

Side panels can slide off hinge pins when vehicle is parked on grade.
Falling side panels can cause injury or death to personnel.

NOTE

This procedure is a two soldier task.

1. Remove lockpin (1) and pull latch (2) up while assistant holds side panel (3).

LOWER CARGO BODY SIDE PANELS ONE AT A TIME - Continued

Figure 1.

2. Lower side panel (3).
3. Pull latch (4) up while assistant holds side panel (5).
4. Lower side panel (5).
5. Remove lockpin (6) while assistant holds side panel (7).
6. Lower side panel (7).

LOWER CARGO BODY SIDE PANELS ALL AT ONE TIME**WARNING**

Side panels can slide off hinge pins when vehicle is parked on grade. Falling side panels can cause injury or death to personnel.

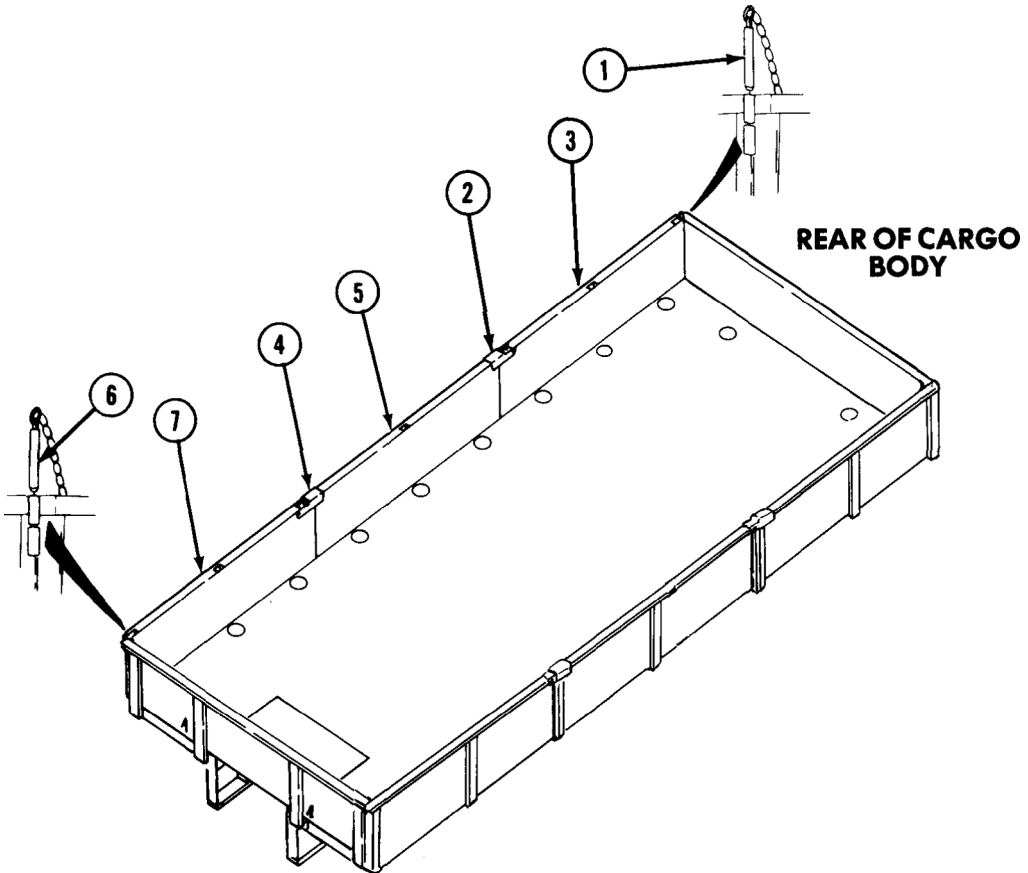
NOTE

This procedure is a two soldier task.

1. Hold side panel (1) up while assistant removes lockpins (2) and climbs out of cargo body to help lower side panels.

LOWER CARGO BODY SIDE PANELS ALL AT ONE TIME - Continued

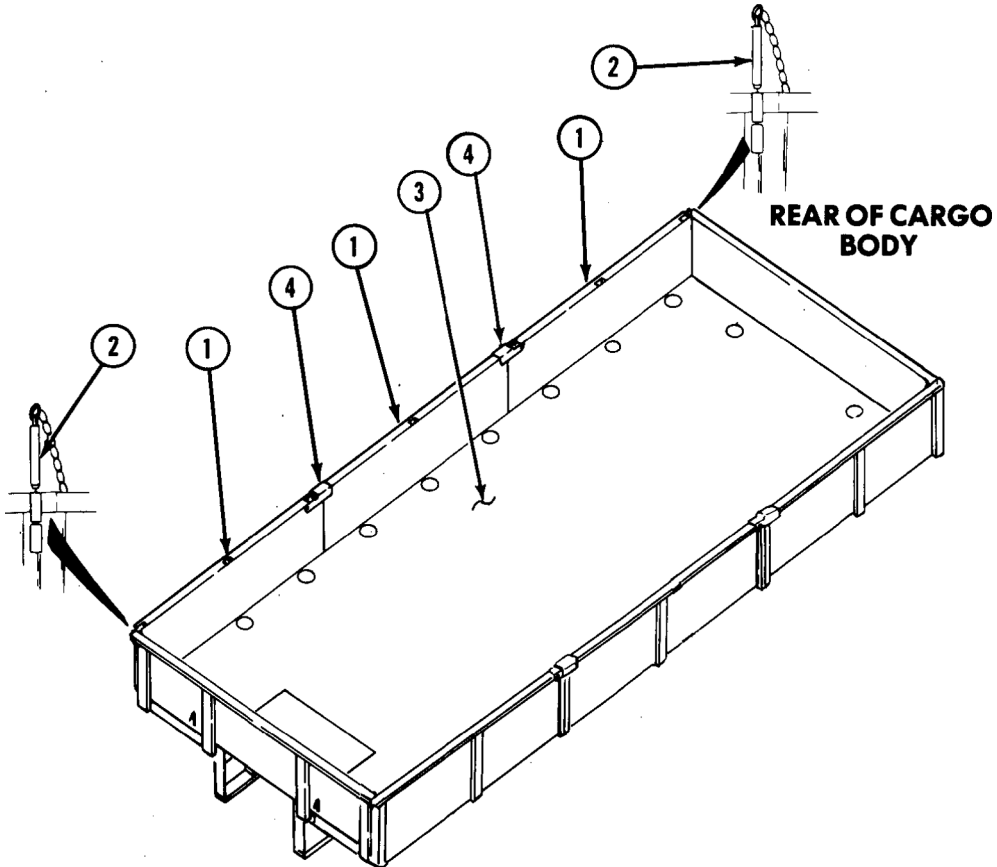

Figure 2.

2. With aid of an assistant, lower side panels (1) until side panels are even with cargo body floor (3).
3. Change hand position so each soldier holds a latch (4).
4. With aid of an assistant, lower side panels (1).

RAISE AND SECURE CARGO BODY SIDE PANELS ONE AT A TIME**WARNING**

Side panels can slide off hinge pins when vehicle is parked on grade. Falling side panels can cause injury or death to personnel.

NOTE

This procedure is a two soldier task.

1. Raise and hold side panel (1) while assistant installs lockpins (2) and pulls latch (3) up.

RAISE AND SECURE CARGO BODY SIDE PANELS ONE AT A TIME - Continued

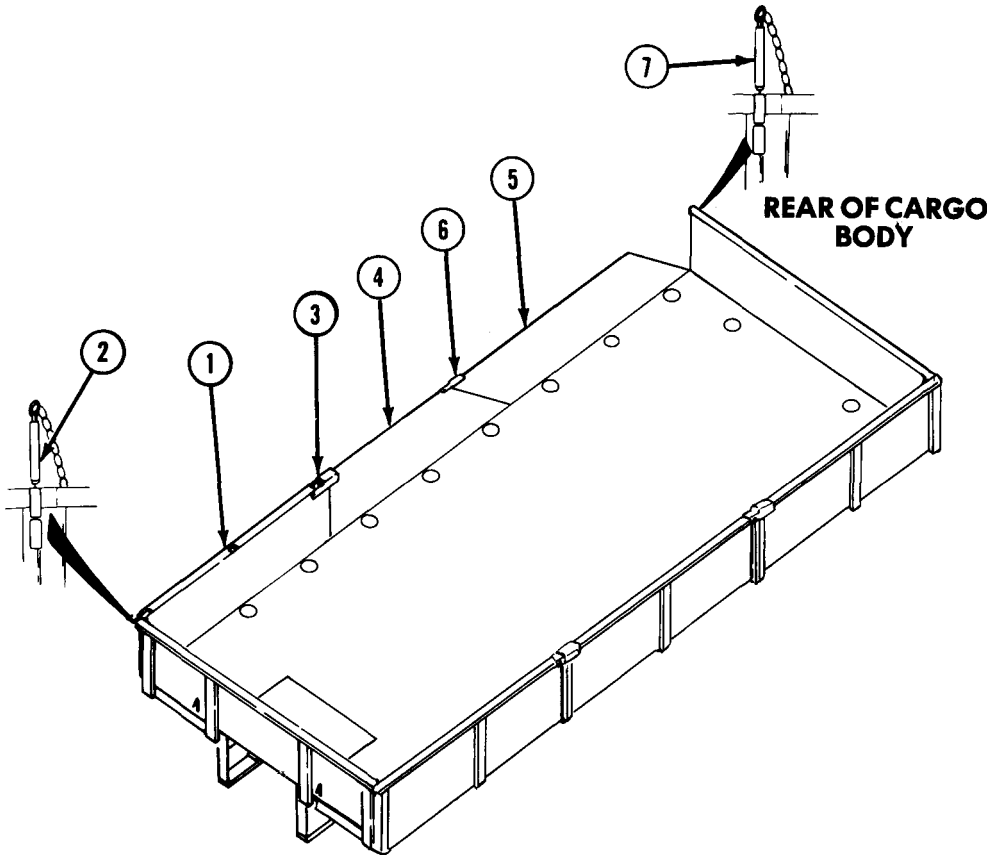
*Figure 3.*

2. Raise and hold side panel (4) while assistant pushes latch (3) down.
3. Raise and hold side panel (5) while assistant pulls latch (6) up and installs lockpin (7).
4. Push latch (6) down.

RAISE AND SECURE CARGO BODY SIDE PANELS ALL AT A TIME**WARNING**

Side panels can slide off hinge pins when vehicle is parked on grade. Falling side panels can cause injury or death to personnel.

NOTE

This procedure is a two soldier task.

1. With aid of an assistant, place latches (1) over edge of adjoining panel (2).

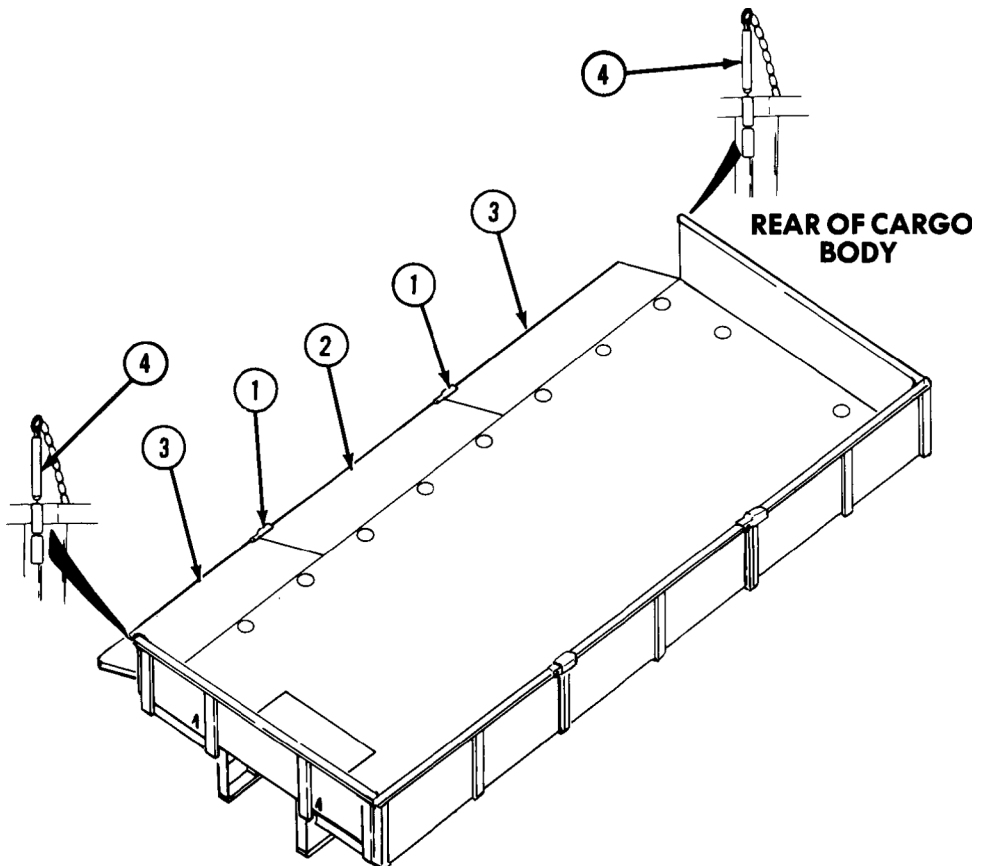

Figure 4.

RAISE AND SECURE CARGO BODY SIDE PANELS ALL AT A TIME - Continued

2. With aid of an assistant, while holding latches (1) in place, raise three side panels (2 and 3).
3. Hold side panels (2 and 3) up, while assistant climbs into cargo body and installs lockpins (4).

REMOVE CARGO BODY FRONT AND REAR PANELS**NOTE**

- This procedure is a two soldier task.
 - All front and rear panels are removed the same way.
 - M985 E1/GMT only has a front panel.
1. Lower cargo body side panels all at the same time.

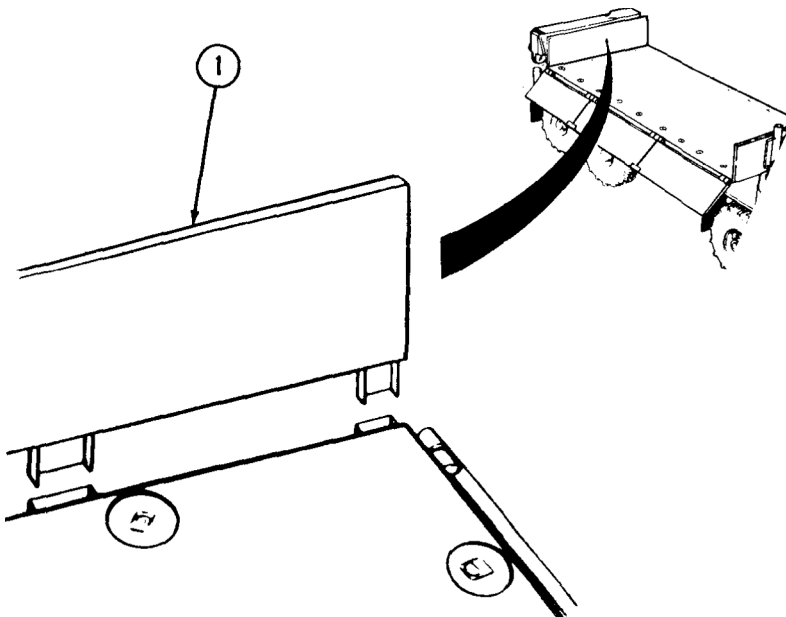
*Figure 5.*

2. Remove rear panel (1) from cargo body.

INSTALL CARGO BODY FRONT AND REAR PANELS**NOTE**

- This procedure is a two soldier task.
- All front and rear panels are installed the same way.
- M985 E1/GMT only has a front panel.

1. Install rear panel (1) on cargo body.

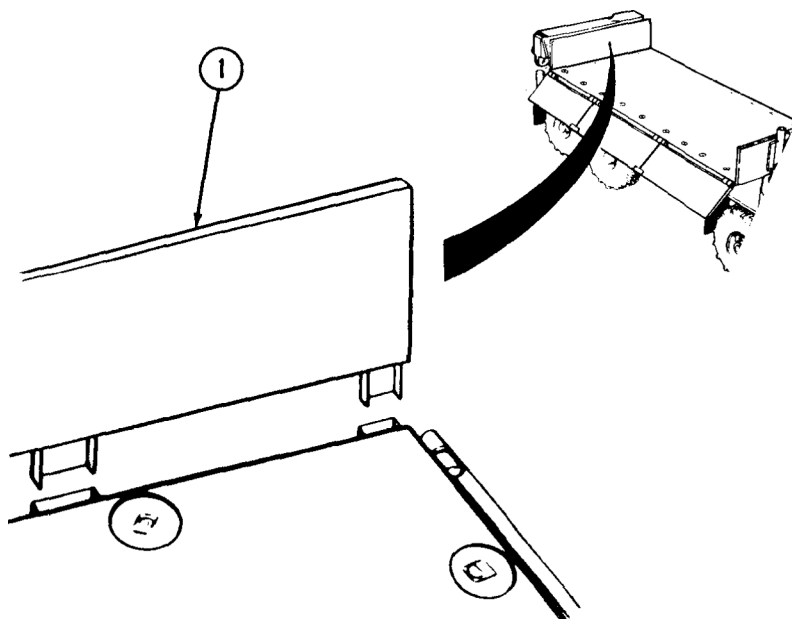

Figure 6.

2. Raise and secure cargo side panels all at one time.

REMOVE CARGO BODY SIDE PANELS**NOTE**

- This procedure is a two soldier task.
- All driver side and passenger side panels are removed the same way.

1. Lower cargo body side panels one at a time.

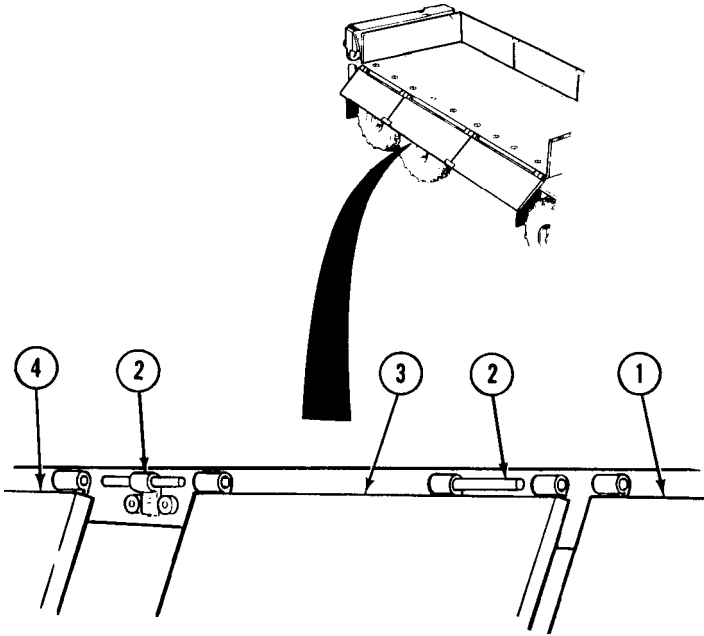
REMOVE CARGO BODY SIDE PANELS - Continued*Figure 7.*

2. Raise front side panel (1) and slide panel forward off two pins (2).
3. Raise center side panel (3) and slide panel forward off two pins (2).
4. Raise rear side panel (4) and slide panel rearward off two pins (2).

INSTALL CARGO BODY SIDE PANELS**NOTE**

- This procedure is a two soldier task.
- All driver side and passenger side panels are installed the same way.

1. Install rear side panel (4) on two pins (2) and slide forward.

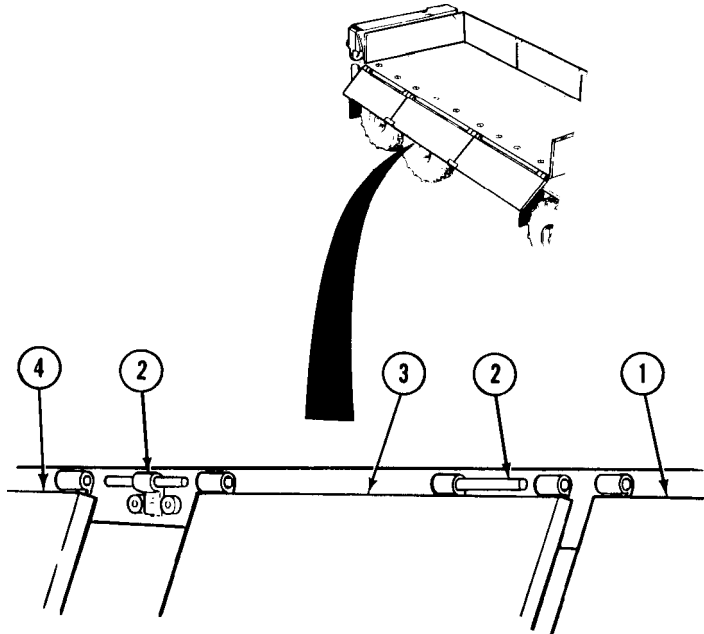
INSTALL CARGO BODY SIDE PANELS - Continued*Figure 8.*

2. Install center side panel (3) on two pins (2) and slide rearward.
3. With aid of an assistant, install front side panel (1) on two pins (2) and slide rearward.
4. Raise and secure cargo body side panels one at a time.

INSTALL CARGO COVER KIT**NOTE**

This procedure is a two soldier task.

1. Park vehicle. (WP 0056)
2. Shut off engine. (WP 0057)
3. Install stakes (1) in top edge of side panels (2).

INSTALL CARGO COVER KIT - Continued

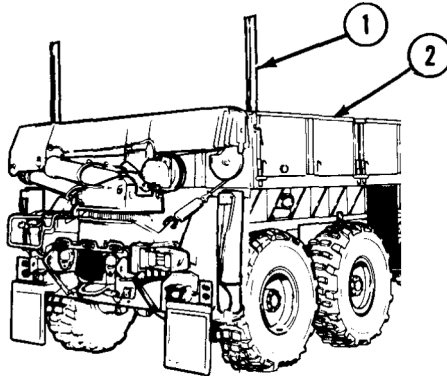

Figure 9.

4. Install bow (3) on stakes (1).

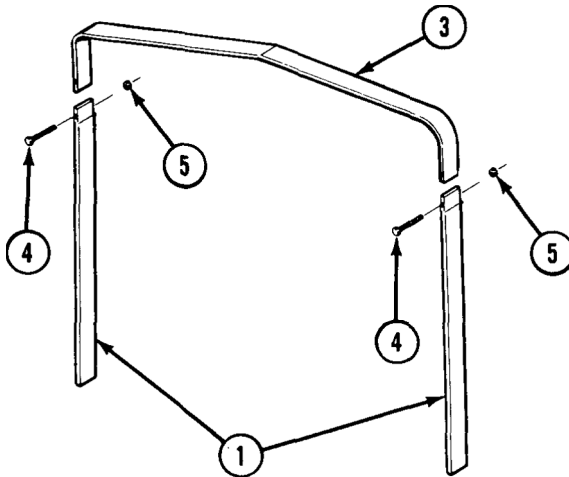

Figure 10.

5. Install two screws (4) and nuts (5).
6. Repeat Steps (3) through (5) for remaining bows and stakes.
7. Remove straps (6) from cargo cover (7), frontgate curtain (8), and tailgate curtain (9).

INSTALL CARGO COVER KIT - Continued

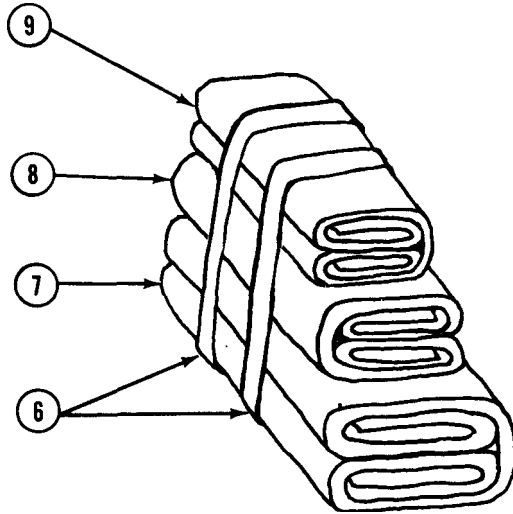

Figure 11.

8. Pull one lashing rope (10) through center eyelet (11) on tailgate curtain (9) until both ends of rope are even.

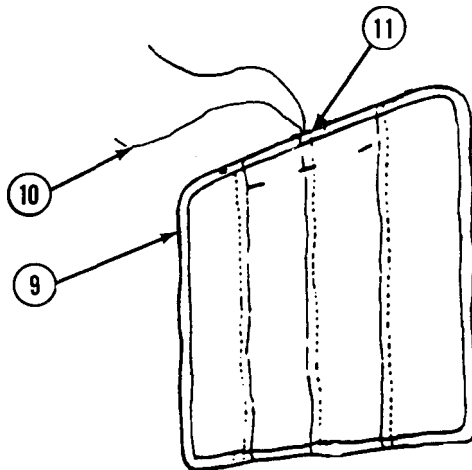

Figure 12.

9. With aid of an assistant, place tailgate curtain (9) on rear rib (12) so stitching is on inside.

INSTALL CARGO COVER KIT - Continued

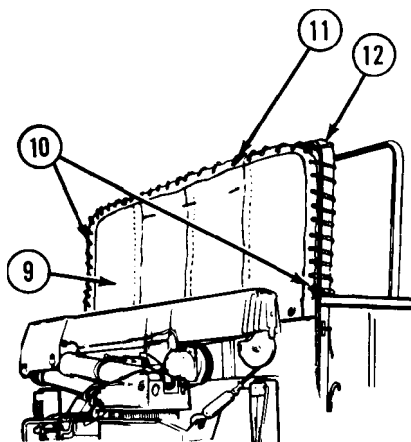

Figure 13.

10. Hold tailgate curtain (9) in place while assistant laces lashing rope (10) around rear rib (12) and through all eyelets (11).

NOTE

Both bottom-corner eyelets are secured in the same way. Passenger side shown.

11. Run end of lashing rope (10) through bottom-corner eyelet (13).

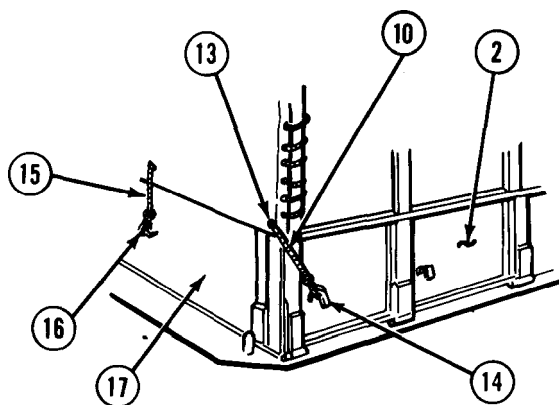

Figure 14.

12. Tie end of lashing rope (10) to tiedown hook (14) on side panel (2).

INSTALL CARGO COVER KIT - Continued

13. Tie bottom tiedown ropes (15) to tiedown hooks (16) on end panel (17).
14. Repeat Steps (11) through (13) for other side.
15. Install frontgate curtain same as tailgate.
16. With aid of an assistant, place cargo cover (7) on rib (18).

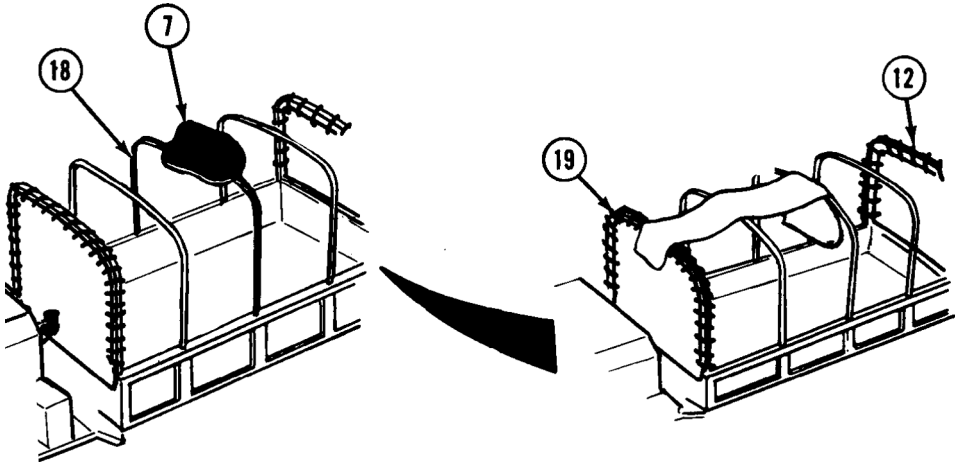

Figure 15.

17. Hold cargo cover (7) steady while assistant unfolds cargo cover to front rib (19) and rear rib (12).
18. Hold cargo cover (7) in place while assistant unfolds cargo cover over sides.

INSTALL CARGO COVER KIT - Continued

Figure 16.

CAUTION

Do not tie lashing ropes too tight or cargo cover may tear.

NOTE

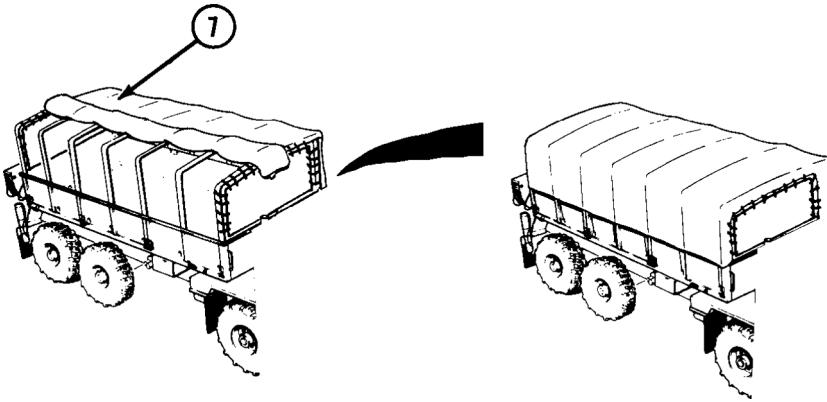
All corners are secured in the same way. Forward passenger side corner shown.

19. Tie front corner tiedown rope (20) to tiedown hook (16).

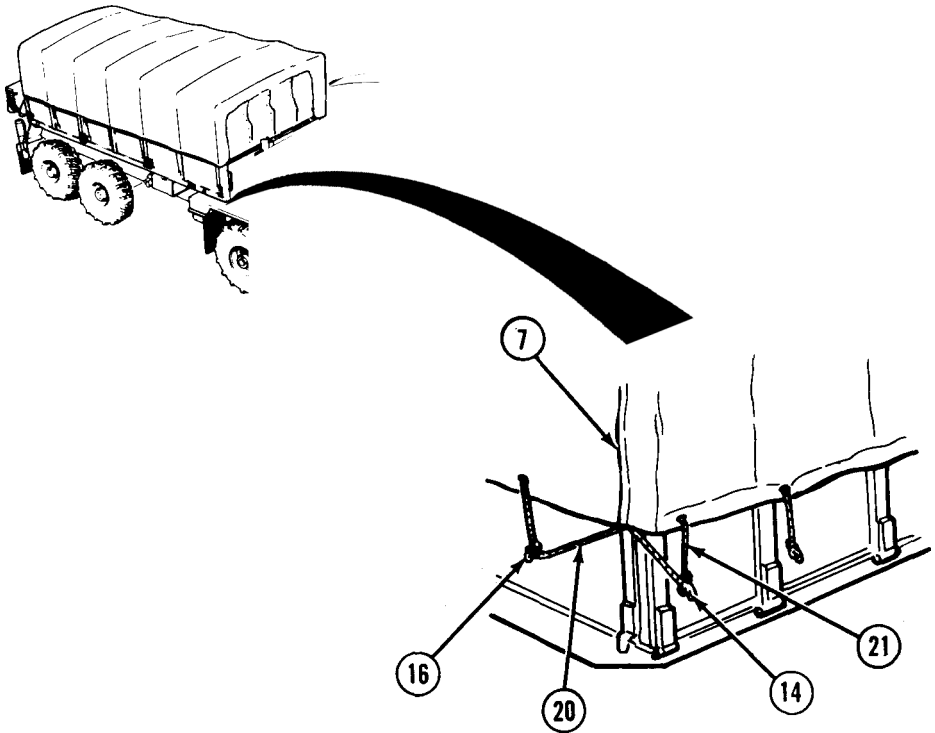
INSTALL CARGO COVER KIT - Continued*Figure 17.*

20. Pull all slack out of cargo cover (7).
21. Repeat Steps (19) and (20) on remaining three corners.
22. Tie remaining lashing ropes (21) to remaining tiedown hooks (14).

REMOVE CARGO COVER KIT**NOTE**

This procedure is a two soldier task.

1. Park vehicle. (WP 0056)
2. Shut off engine. (WP 0057)

NOTE

All corners are untied in the same way. Forward passenger side corner shown.

REMOVE CARGO COVER KIT - Continued

3. Untie both front corner tiedown ropes (1) from tiedown hooks (2).

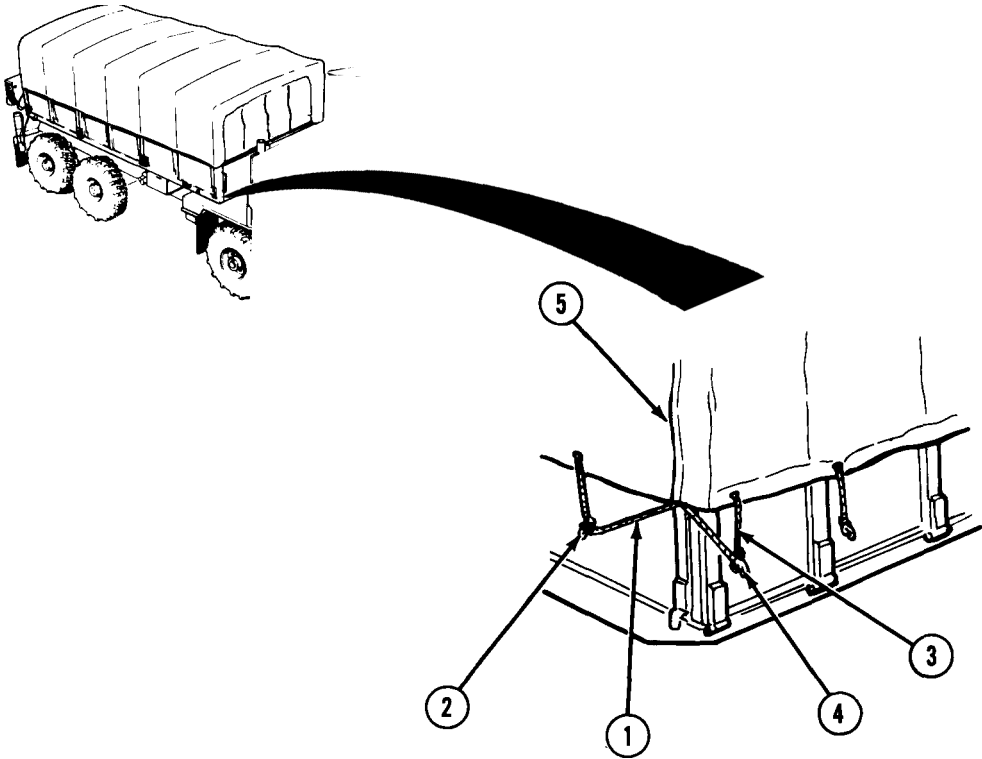
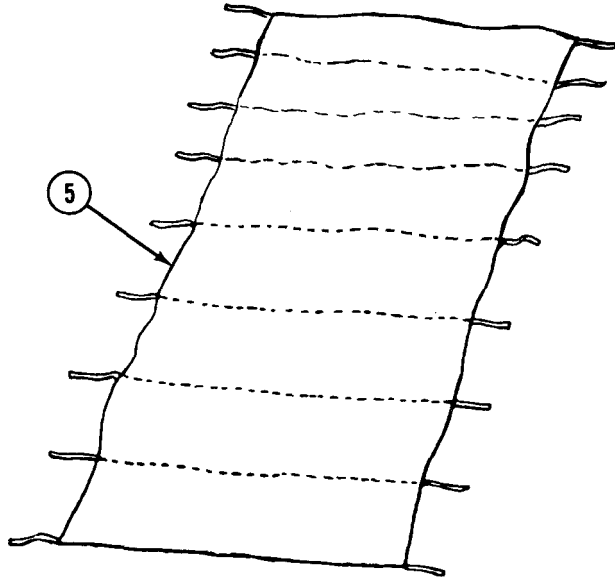

Figure 18.

4. Repeat Step (3) for remaining three corners.
5. Untie lashing ropes (3) from all tiedown hooks (4) on each side of vehicle.
6. With aid of an assistant, remove cargo cover (5) from vehicle.
7. With aid of an assistant, spread cargo cover (5) on smooth, dry surface so stitching is facing down.

REMOVE CARGO COVER KIT - Continued*Figure 19.***CAUTION**

Do not fold cargo cover if it is wet. Cargo cover will mildew if stowed when wet.

8. With aid of an assistant, fold one side of cargo cover (5) towards center in two folds. Make each fold about 2 ft. (61 cm) wide.

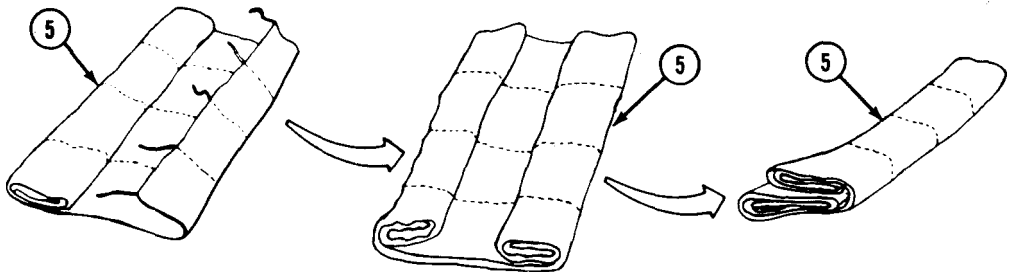
*Figure 20.*

9. With aid of an assistant, fold other side of cargo cover (5) towards center in two folds.
10. Fold both sides of cargo cover (5) together.

REMOVE CARGO COVER KIT - Continued

11. Fold one end of cargo cover (5) towards center in two folds. Make each fold about 3 ft. (91 cm) wide.

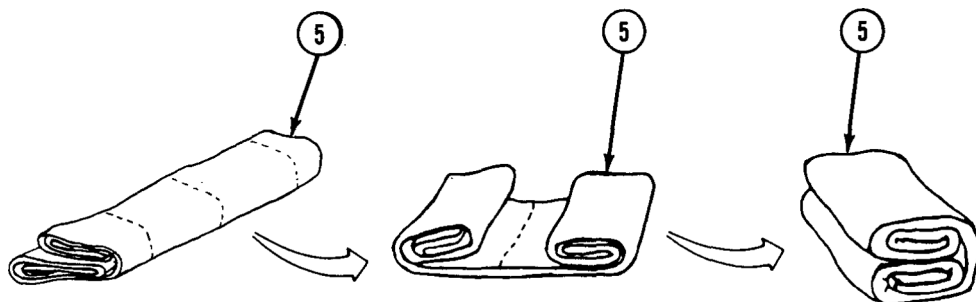

Figure 21.

12. Fold other end of cargo cover (5) towards center in two folds.
 13. Fold both sides of cargo cover (5) together.
 14. Untie bottom tiedown ropes (6) from tiedown hooks (2) on both sides of vehicle.

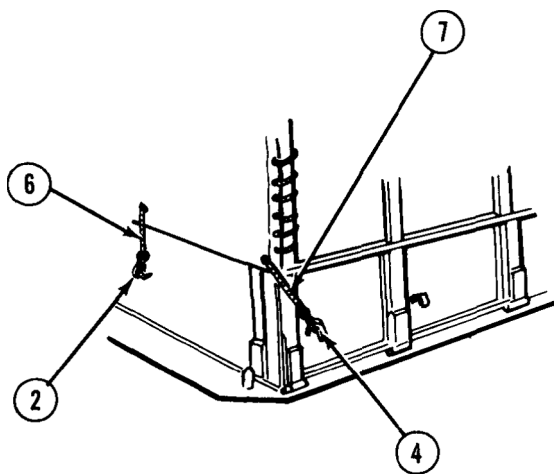
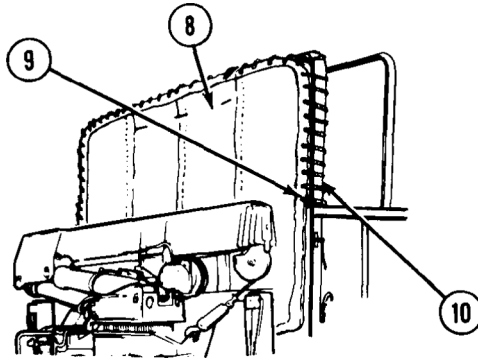
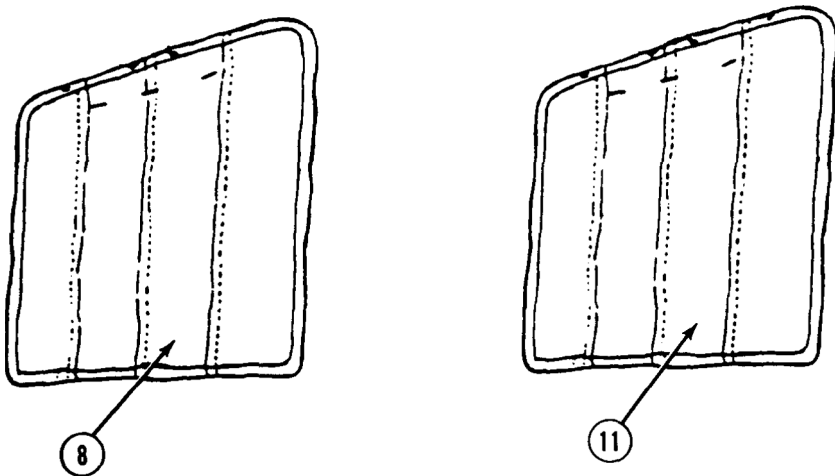

Figure 22.

15. Untie lashing ropes (7) from tiedown hooks (4) on both sides of vehicle.
 16. Hold tailgate curtain (8) while assistant unties lashing rope (9) from rear rib (10).

REMOVE CARGO COVER KIT - Continued*Figure 23.*

17. With aid of an assistant, remove tailgate curtain (8).
18. Repeat Steps (14) through (17) to remove frontgate curtain.
19. With aid of an assistant, lay tail gate curtain (8) and frontgate curtain (11) on smooth, dry surface so stitching is facing down.

*Figure 24.***CAUTION**

Do not fold tailgate or frontgate curtains when wet. Curtains will mildew if stowed when wet.

20. With aid of an assistant, fold one side of tailgate curtain (8) toward center in two folds.

REMOVE CARGO COVER KIT - Continued

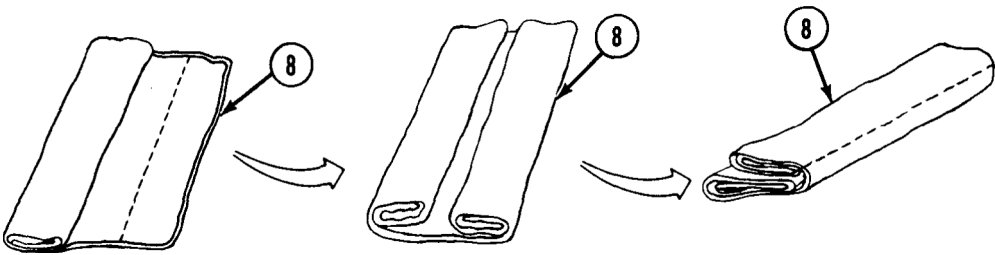

Figure 25.

21. With aid of an assistant, fold other side of tailgate curtain (8) toward center in two folds.
22. Fold both sides of tailgate curtain (8) together.
23. Fold one end of tailgate curtain (8) toward center in two folds.

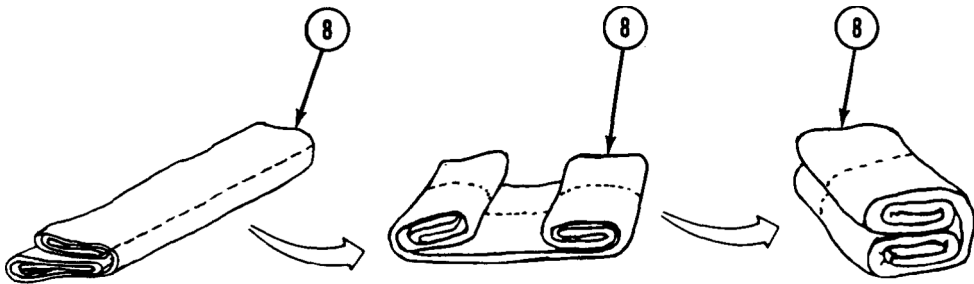
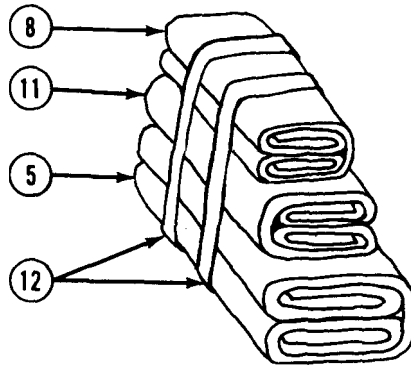
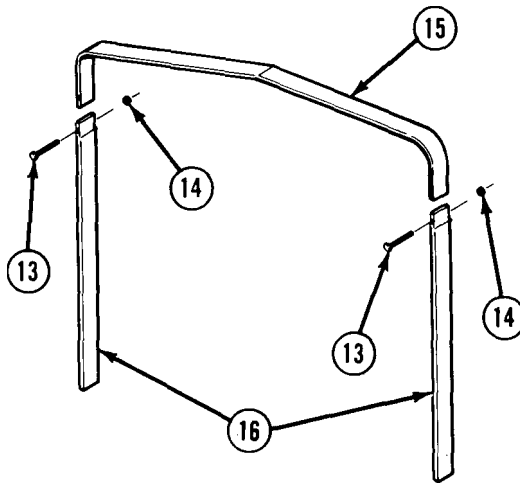

Figure 26.

24. Fold other end of tailgate curtain (8) toward center in two folds.
25. Fold both sides of tailgate curtain (8) together.
26. Repeat Steps (20) through (25) for frontgate curtain.
27. Bind curtains (8 and 11) and cargo cover (5) with straps (12).

REMOVE CARGO COVER KIT - Continued*Figure 27.*

28. Remove two screws (13) and nuts (14).

*Figure 28.*

29. Remove bow (15) from stakes (16).
 30. Repeat Steps (28) and (29) for remaining bows and stakes.
 31. With aid of an assistant, remove stakes (16).

REMOVE CARGO COVER KIT - Continued

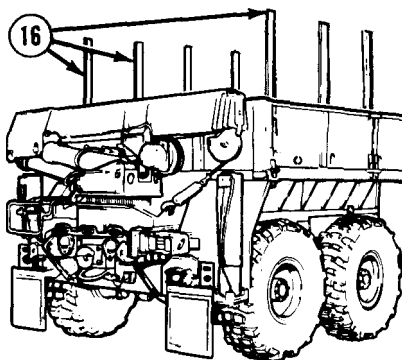

Figure 29.

END OF TASK

END OF WORK PACKAGE

**OPERATOR MAINTENANCE
GROVE CRANE OPERATION (MANUAL CONTROL)**

INITIAL SETUP:

Not Applicable

PREPARE CRANE FOR USE

WARNING



Stand clear of outrigger beams while operating levers. Failure to comply may result in injury or death to personnel.

1. Chock wheels. (WP 0077)

WARNING

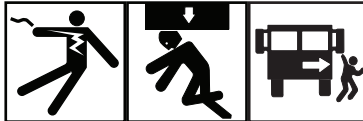

- Stand clear of outrigger beams while operating levers. Failure to comply may result in injury or death to personnel.
- Do not operate crane unless outriggers are firmly in place or vehicle could turn over. Failure to comply may result in injury or death to personnel.
- Keep boom clear of all electrical lines and other obstacles while operating crane. Failure to comply may result in injury or death to personnel.

PREPARE CRANE FOR USE - Continued**WARNING**

If operator cannot see load during operation, operate crane from REMOTE CONTROL UNIT. Failure to comply may result in injury or death to personnel.

NOTE

- Failure of hydraulic system will stop crane operation and lock crane in place. If hydraulic system fails during crane operation, refer to perform immediate action for loss of hydraulic system. (WP 0103)
- If electrical system fails during crane operation, refer to perform emergency hydraulic operation when grove crane electrical power fails. (WP 0104)
- Grove crane can operate on up to 5-degree side slope.

2. Start engine. (WP 0044)
3. Position vehicle on level ground so all loading and unloading can be done from one position.
4. Set transmission range selector (1) to N (neutral).

NOTE

Dashboard parking brake indicator will illuminate when PARKING BRAKE control is applied.

5. Pull out PARKING BRAKE control (2).

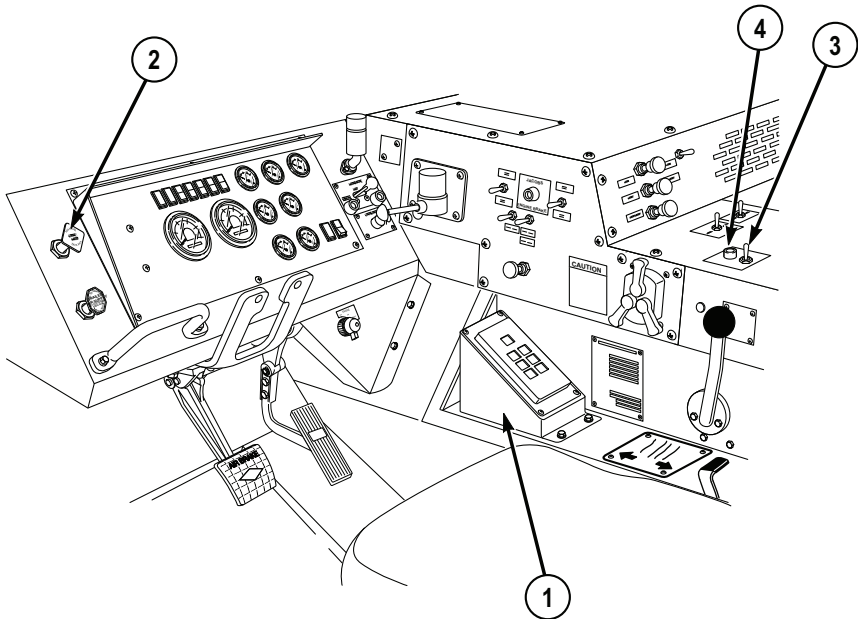
PREPARE CRANE FOR USE - Continued*Figure 1.*

6. Set PTO ENGAGE switch (3) to OFF position. Indicator light (4) will go out.

CAUTION

PTO ENGAGE switch must be in OFF position before moving hydraulic selector valve control to prevent equipment damage.

7. Push hydraulic selector valve control (5) in for crane operation.

PREPARE CRANE FOR USE - Continued

Figure 2.

8. Set PTO ENGAGE switch (3) to ON position. Indicator light (4) will illuminate.

PREPARE CRANE FOR USE - Continued

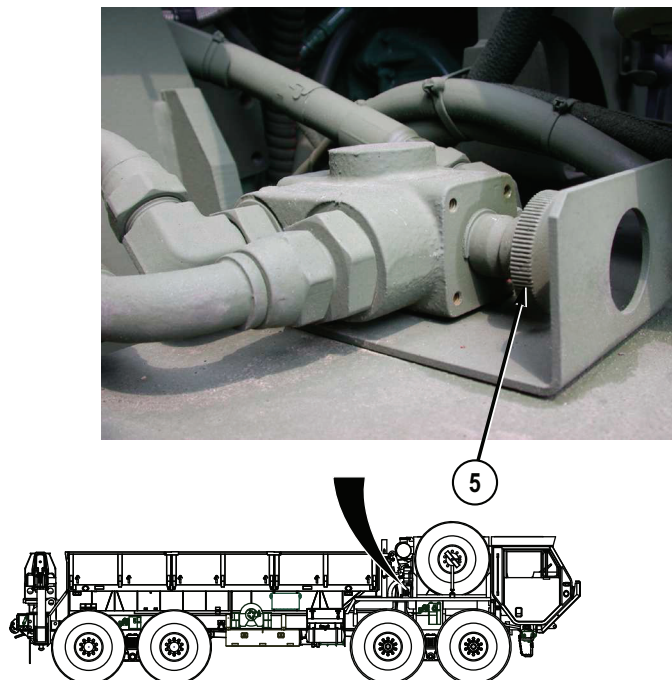
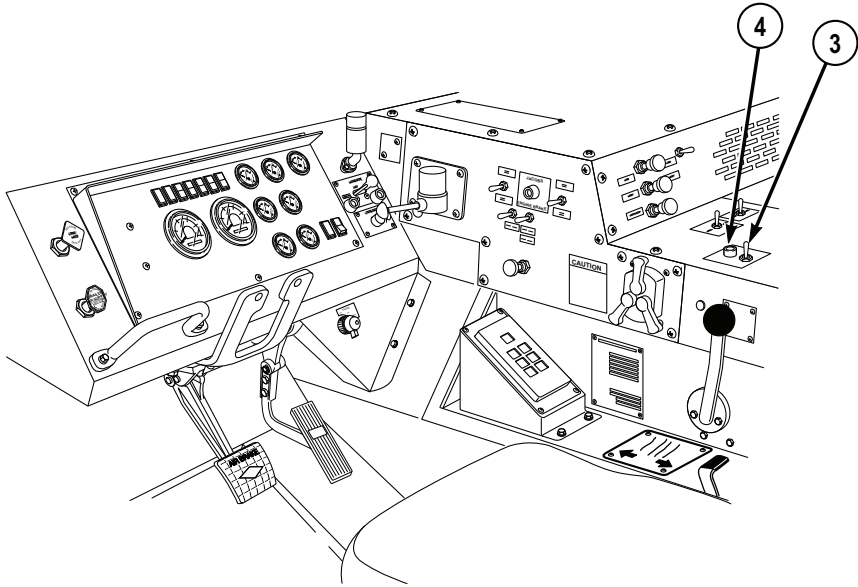

Figure 3.

9. Set electric control box ON/OFF POWER switch (6) to ON position.

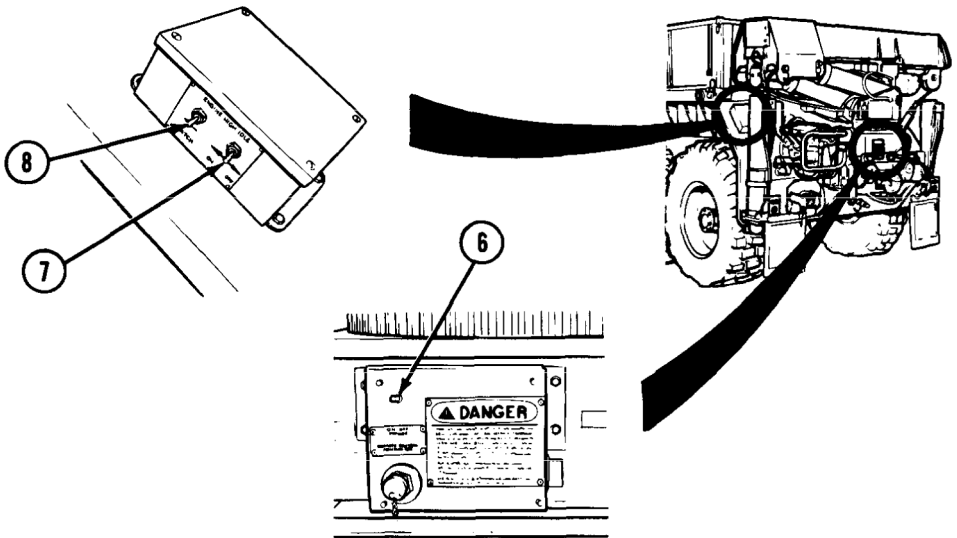

Figure 4.

PREPARE CRANE FOR USE - Continued

10. Set ENGINE HIGH IDLE ON/OFF switch (7) to ON position.
11. Push up and release LATCH switch (8) to raise engine speed to approximately 1500 rpm.

SETUP OUTRIGGERS**WARNING**

Stand clear of outrigger beams while operating levers. Failure to comply may result in injury or death to personnel.

NOTE

- Always operate control levers with light, even pressure.
 - Outrigger beams will come out slower with light pressure on lever. Pushing lever to full travel will cause faster movement.
 - Although either right or left side outrigger may extend first, both outriggers will extend when O/R EXT control lever is positioned to OUT.
1. Move outrigger extension (O/R EXT) control lever (1) to OUT position until right and left outrigger beams (2) are fully extended.

SETUP OUTRIGGERS - Continued

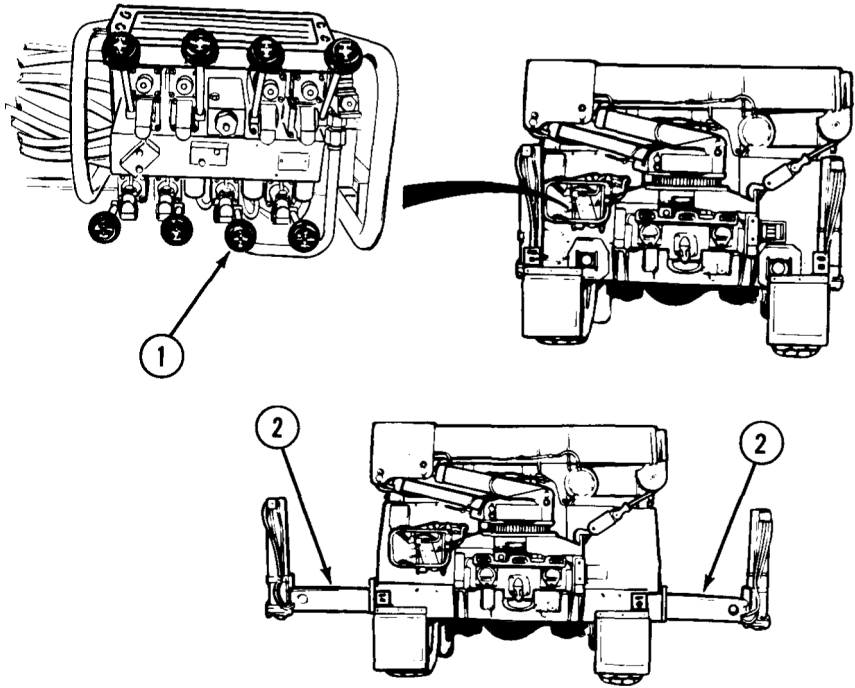

Figure 5.

WARNING



Stand clear of outrigger beams while operating levers. Failure to comply may result in injury or death to personnel.

NOTE

Outrigger pad on passenger side is shown. Driver side is the same.

2. Remove two safety pins (3) and remove outrigger pad (4) from studs (5) on outrigger beam (2).

SETUP OUTRIGGERS - Continued

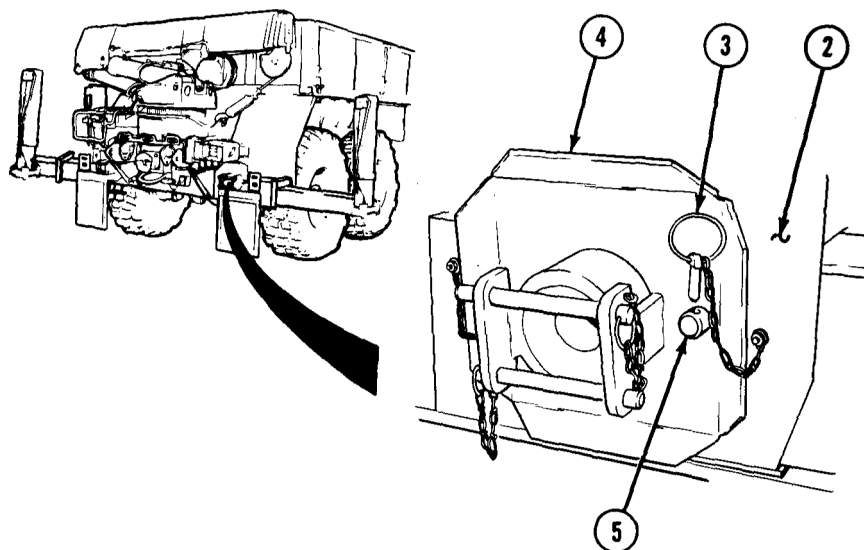

Figure 6.

3. Remove two retaining pins (6).

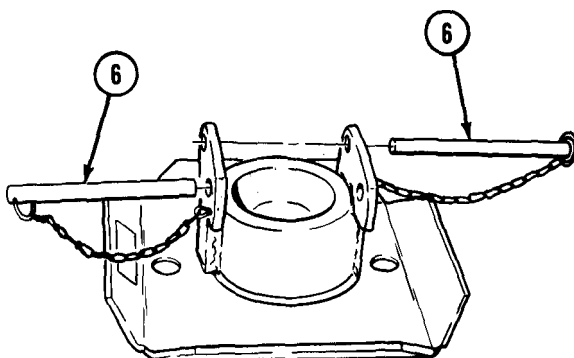
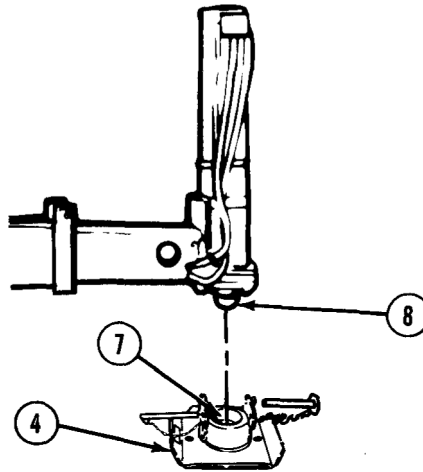
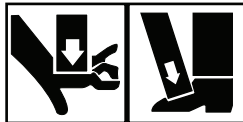

Figure 7.

4. Clean all foreign material from socket (7) in outrigger pad (4) and from rod end of outrigger jack cylinder (8).

SETUP OUTRIGGERS - Continued*Figure 8.*

5. Position outrigger pad (4) directly below outrigger jack cylinder (8).
6. Repeat Steps (2) through (5) to set up driver side outrigger pad.

WARNING

Keep hands and feet clear of outrigger jack cylinders. Failure to comply may result in injury or death to personnel.

NOTE

Adjust outrigger pad position as required so rod end will lower into pad socket.

7. Move left-hand outrigger jack (LH O/R JACK) control lever (9) to DOWN position and lower outrigger jack cylinder (8) until rod end is seated in outrigger pad (4).

SETUP OUTRIGGERS - Continued

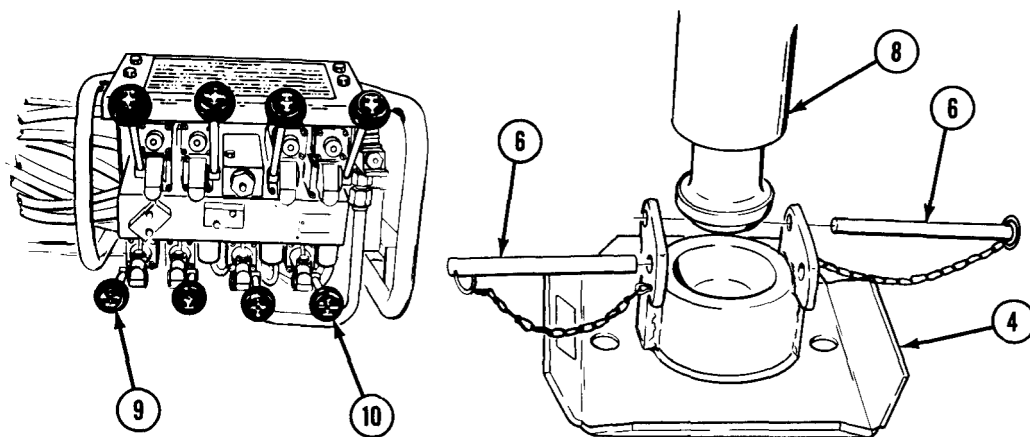

Figure 9.

8. Install two retaining pins (6).
9. Move right-hand outrigger jack (RH O/R JACK) control lever (10) to DOWN position and lower outrigger cylinder (8) until rod end is seated in outrigger pad (4).
10. Install two retaining pins (6).

JACK OUTRIGGERS

WARNING



- Do not raise vehicle tires off ground with outrigger jack cylinders. Vehicle could roll over. Always chock front wheels when using outriggers. Failure to comply may result in injury or death to personnel.
- Crane must be level from side to side. Use of crane in unlevel position can cause vehicle to turn. Failure to comply may result in injury or death to personnel.

NOTE

- Operate left and right outrigger jack (LH O/R JACK and RH O/R JACK) control levers at same time.

JACK OUTRIGGERS - Continued

- Crane movement from one lever may be slower than the other when operating two levers together.
1. Simultaneously move left-hand (1) outrigger jack (LH O/R JACK) and right-hand (2) outrigger jack (RH O/R JACK) control levers to DOWN position.

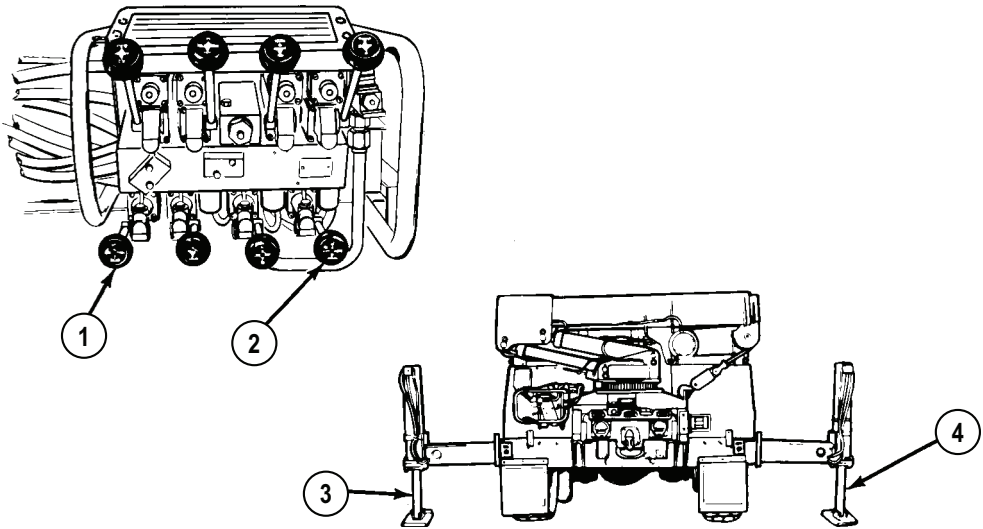
*Figure 10.***NOTE**

Vehicle weight should be off No. 4 axle just enough so tires still have firm contact with ground but no longer bulge from weight of vehicle.

2. Lower driver side (3) and passenger side (4) outrigger jack cylinders until vehicle weight is off rear tires.

RAISE BOOM TO OPERATING POSITION**WARNING**

Do not operate crane unless outriggers are firmly in place or vehicle could turn over. Failure to comply may result in injury or death to personnel.

RAISE BOOM TO OPERATING POSITION - Continued**CAUTION**

Do not let cable unwind and become slack or cable may get tangled on drum.

1. Move HOIST control lever (1) to DOWN position and lower hoist cable (2) approximately 1 ft. (30 cm).

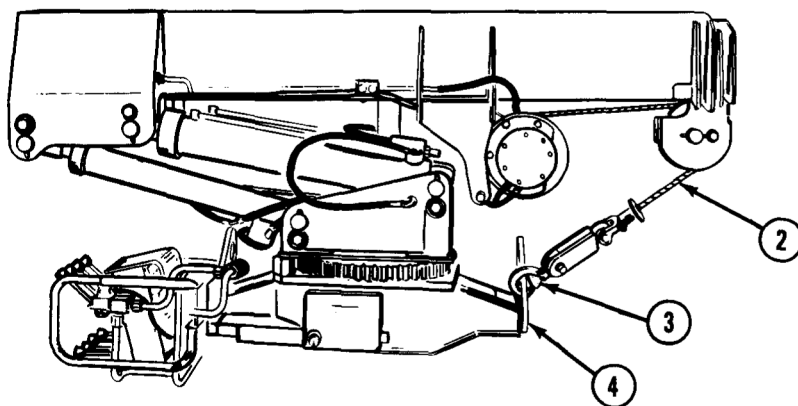
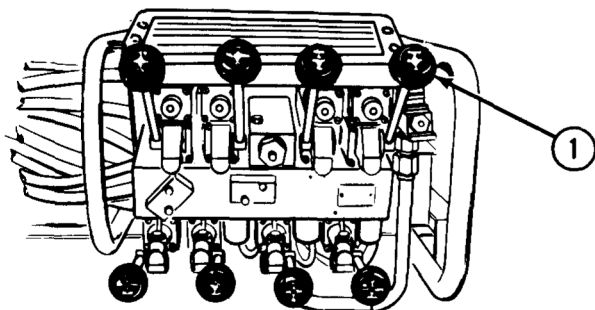

Figure 11.

CAUTION

- Release hook lock before disconnecting load hook from stowage ring bracket to avoid hook lock damage.
- Do not let load hook fall and hit bracket.

2. Disconnect load hook (3) from stowage ring bracket (4).

RAISE BOOM TO OPERATING POSITION - Continued**WARNING**

When using crane on any vehicle, park vehicle clear of all overhead electrical lines. Keep boom clear of all electrical lines and other obstacles while operating crane. Failure to comply may result in injury or death to personnel.

3. Move BOOM control lever (5) to UP position until boom (6) is approximately 45 degrees above horizontal.

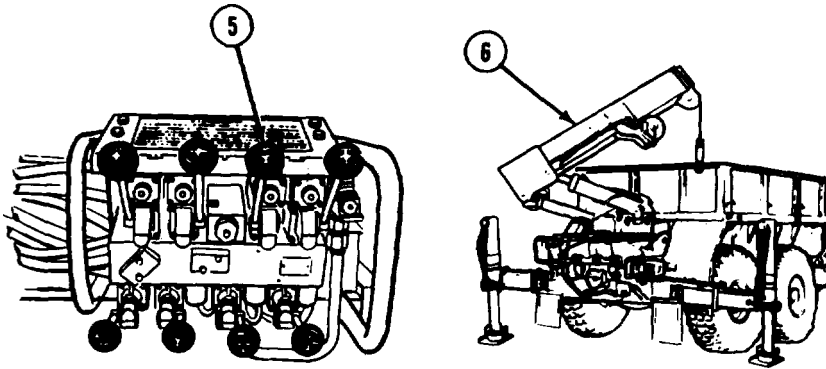
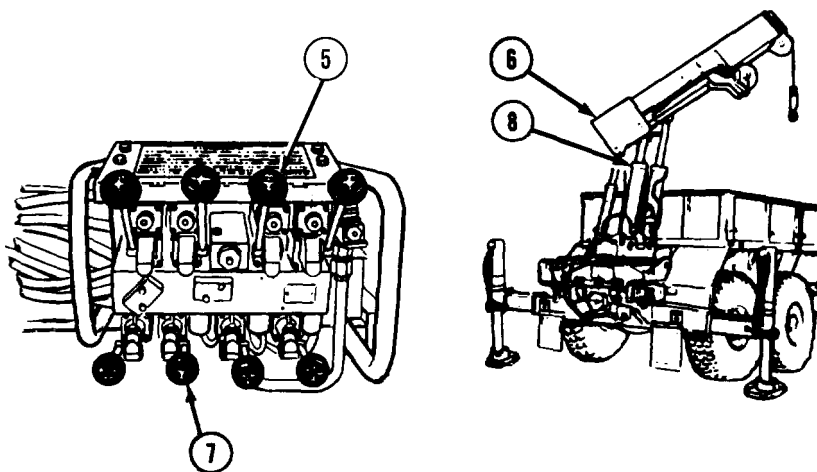

Figure 12.

CAUTION

To avoid damage to outrigger leg or load hook, do not hit outrigger leg with load hook.

4. Move MAST control lever (7) to UP position until the mast (8) is fully erect and the cylinders are fully extended.

RAISE BOOM TO OPERATING POSITION - Continued*Figure 13.*

5. Move BOOM control lever (5) to UP position simultaneously as required to maintain the boom (6) at approximately 45 degrees above horizontal until the mast (8) is fully erect.
6. Hold MAST control lever (7) to UP position for two to three seconds after mast (8) is fully erect to ensure cylinders are fully filled with oil.
7. Operate crane with manual controls or remote-control unit. (WP 0043)

ROTATE AND TELESCOPE BOOM**WARNING**

- When using crane on any vehicle, park vehicle clear of all overhead electrical lines. Keep boom clear of all electrical lines and other obstacles while operating crane. Failure to comply may result in injury or death to personnel.
- Ensure area is clear of personnel prior to moving SWING control lever. Boom should be swung slowly enough so crane operator has complete control. If operator cannot see load during operation, operate crane from REMOTE CONTROL UNIT. Failure to comply may result in injury or death to personnel.

ROTATE AND TELESCOPE BOOM - Continued

- Operator must keep control of load at all times. If necessary, attach cargo tiedowns to load for control. Failure to comply may result in injury or death to personnel.
- If electrical power fails during crane operation, move switch on REMOTE CONTROL UNIT to SHUTDOWN position. Failure to comply may result in injury or death to personnel.

CAUTION

Boom must be above vehicle sides for clearance. Hitting side of vehicle with boom may cause damage to boom or vehicle.

NOTE

Operate control levers with light, even pressure. Moving lever slightly will cause slow movement of crane. Moving lever to full travel will cause faster movement of crane.

1. Move SWING control lever (1) to CW position to move boom (2) clockwise.

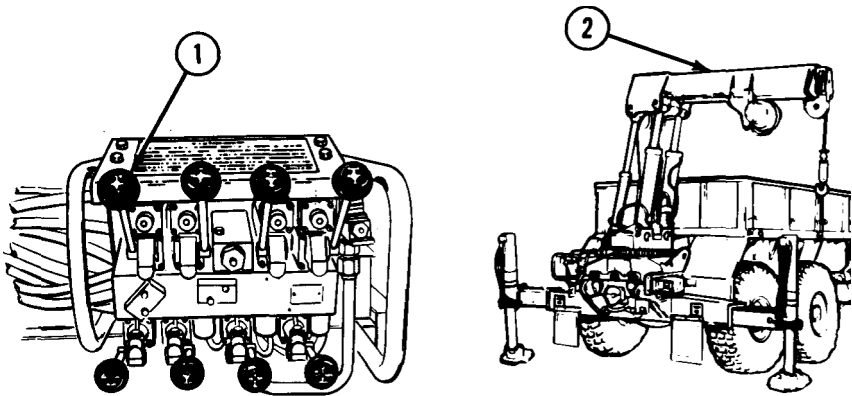

Figure 14.

2. Move SWING control lever (1) to CCW position to move boom (2) counterclockwise.

CAUTION

Keep hook block at least 2 ft. (0.61 m) from end of boom. If hook block hits end of boom it may damage cable or hook block and crane will lose power. Wait six seconds for power to return and check crane for damage.

ROTATE AND TELESCOPE BOOM - Continued**NOTE**

- When crane is overloaded, M977 and M985 overload system will automatically shut off power to telescope boom out, raise boom, or hoist load any higher. The M977 overload system will also prevent lowering boom. Overload condition can be corrected by lowering load to ground or other supporting surface by using HOIST control lever only.
 - When telescoping the boom, the TELESCOPE and HOIST control levers should be operated at the same time.
 - Crane movement from one lever may be slower than the other when operating two levers together.
3. Move TELESCOPE control lever (3) to OUT position to extend boom (2) and move HOIST control lever (4) to DOWN position to pay out cable (5).

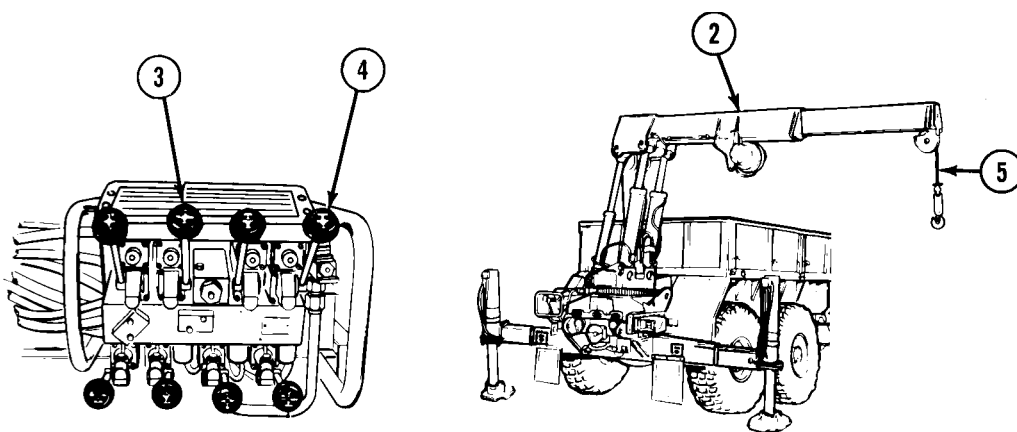
*Figure 15.***CAUTION**

Do not go over maximum load rating as shown on RANGE DIAGRAM. Going over load ratings will cause damage to equipment.

NOTE

When operating M977 crane, raise boom to approximately 60 degree angle to pick up maximum load.

4. Refer RANGE DIAGRAM (6) on turntable panel (7) to raise boom (2) to correct angle before connecting the load.

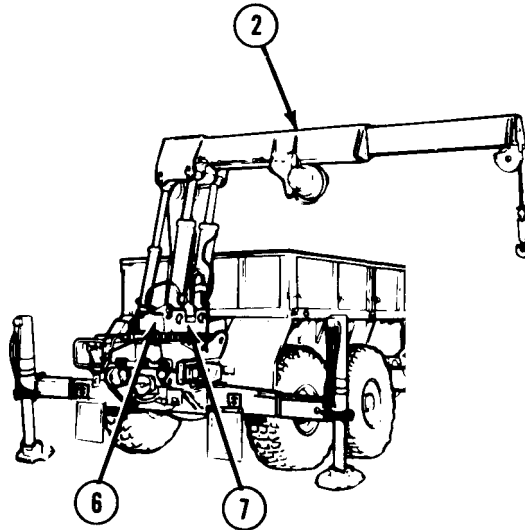
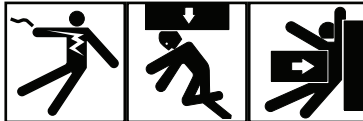
ROTATE AND TELESCOPE BOOM - Continued*Figure 16.***RAISE AND LOWER LOAD****WARNING**

- When using crane on any vehicle, park vehicle clear of all overhead electrical lines. Keep boom clear of all electrical lines and other obstacles while operating crane. Failure to comply may result in injury or death to personnel.
- Ensure area is clear of personnel prior to moving SWING control lever. Boom should be swung slowly enough so crane operator has complete control. If operator cannot see load during operation, operate crane from REMOTE CONTROL UNIT. Failure to comply may result in injury or death to personnel.
- Operator must keep control of load at all times. If necessary, attach cargo tiedowns to load for control. Failure to comply may result in injury or death to personnel.

RAISE AND LOWER LOAD - Continued

- If electrical power fails during crane operation, move switch on REMOTE CONTROL UNIT to SHUTDOWN position. Failure to comply may result in injury or death to personnel.

CAUTION

- Do not let cable become slack or cable may get tangled on drum.
- Do not drag load sideways on ground or damage to crane may result.

1. Operate SWING control lever (1) and center end of boom (2) directly over load.

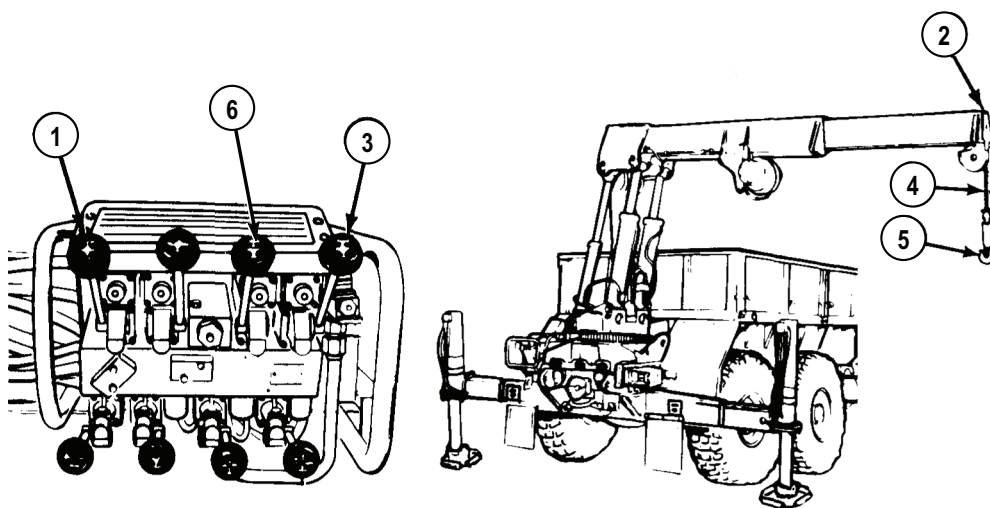

Figure 17.

CAUTION

Release hook lock before connecting load hook to avoid damage to hook lock.

2. Operate HOIST control lever (3) to raise or lower cable (4) and connect load hook (5) to load.

RAISE AND LOWER LOAD - Continued**WARNING**

- Always wear protective gloves when handling winch cable. Never let cable run through hands. Frayed cables can cut severely. Failure to comply may result in injury or death to personnel.
- Never operate winch with less than five wraps of cable on winch drum. Failure to comply may result in injury or death to personnel.

CAUTION

- Do not jerk HOIST control lever or load will bounce causing possible damage to crane or load.
- Do not operate crane with boom below horizontal when there is a load on hook.
- For M977, maximum load limit with boom length under 9 ft. (2.75 m) is 4500 lbs (2 043 kg). Maximum load limit with boom extended over 9 ft. (2.75 m) is 2500 lbs (1 135 kg).
- For M985, maximum load limit is 5400 lbs (2 452 kg) for entire boom reach.

NOTE

- When M977 and M985 crane is overloaded, the overload systems will automatically shut off power to telescope boom out, raise boom, or hoist load any higher.
 - The M977 overload system will also prevent lowering load to ground or other supporting surface. All crane functions will be restored in approximately six seconds.
3. Move HOIST control lever (3) in UP position to lift load. Move BOOM control lever (6) in UP position to raise load higher.
 4. Move HOIST control lever (3) in DOWN position to lower load. Move BOOM control lever (6) in DOWN position to lower load further.
 5. Shutdown crane.

SHUTDOWN CRANE**NOTE**

Steps (1) through (3) are needed only if REMOTE CONTROL UNIT was used during operation.

1. Set ON/OFF POWER switch (1) to ON position.

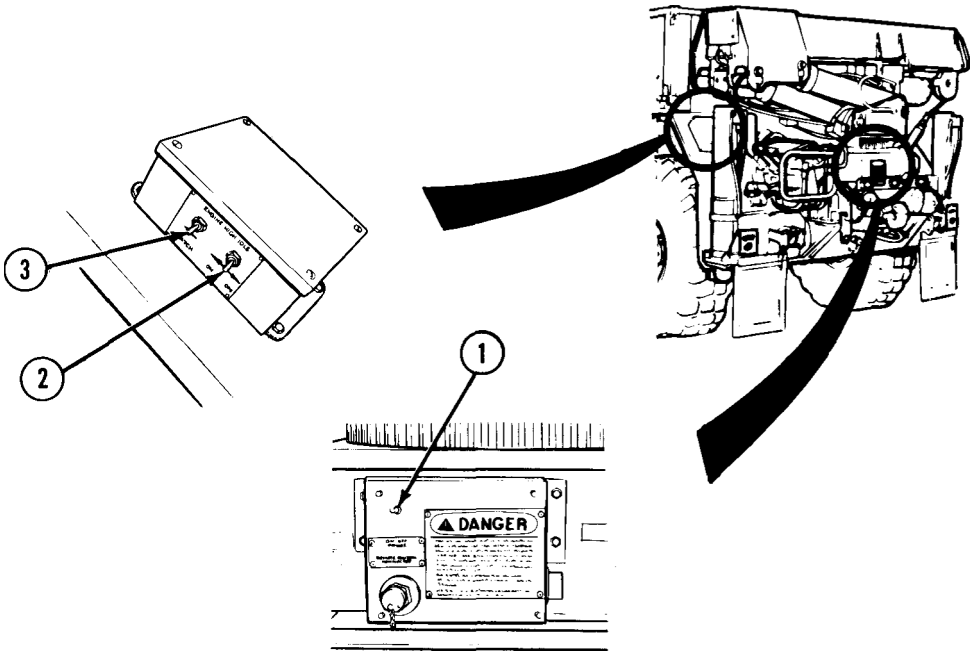

Figure 18.

2. Set ENGINE HIGH IDLE ON/OFF switch (2) to ON position.
3. Push and release LATCH switch (3) to raise engine speed to approximately 1500 rpm.

CAUTION

- Keep hook block at least 2 ft. (0.61 m) from end of boom. If hook block hits end of boom it may damage cable or hook block and crane will lose power. Wait six seconds for power to return and check crane for damage.
- Do not let cable unwind and become slack or cable may get tangled on drum.

SHUTDOWN CRANE - Continued**NOTE**

- Operate control lever with light, even pressure.
 - TELESCOPE and HOIST control levers should be operated at same time to keep hook block at least 2 ft. (0.61) from end of boom.
 - Crane movement from one lever may be slower than the other when operating levers together.
4. Move TELESCOPE control lever (4) to IN position to pull boom extensions (5) in and move HOIST control lever (6) to UP position to reel in cable (7) until all boom extensions (5) are fully retracted.

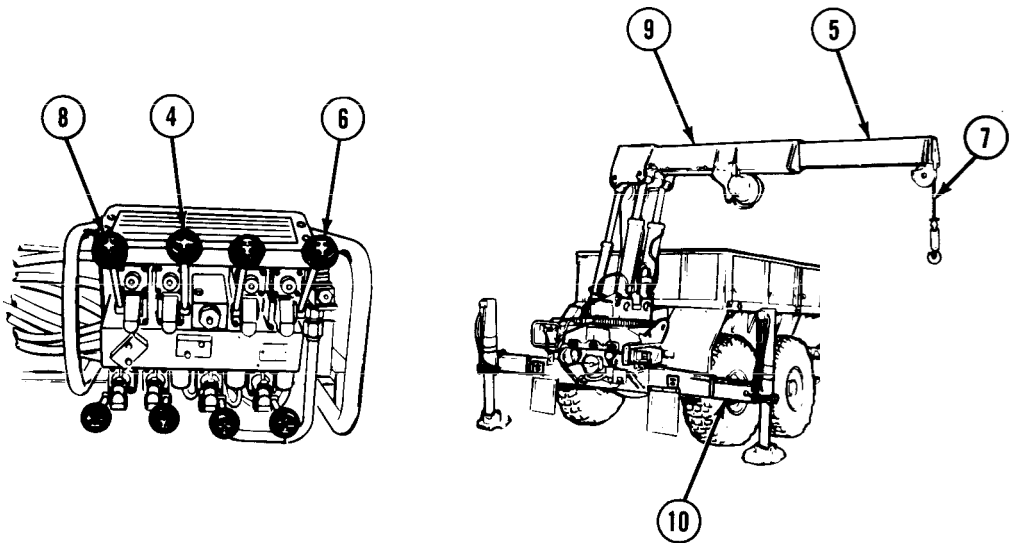
*Figure 19.*

5. Operate SWING control lever (8) to position boom (9) parallel with outrigger beam (10) on passenger side of vehicle.

CAUTION

Boom must rest on rest pad when transporting vehicle. If not, damage to equipment may result.

6. Move MAST control lever (11) to DOWN position to lower mast (12) until mast is completely folded down.

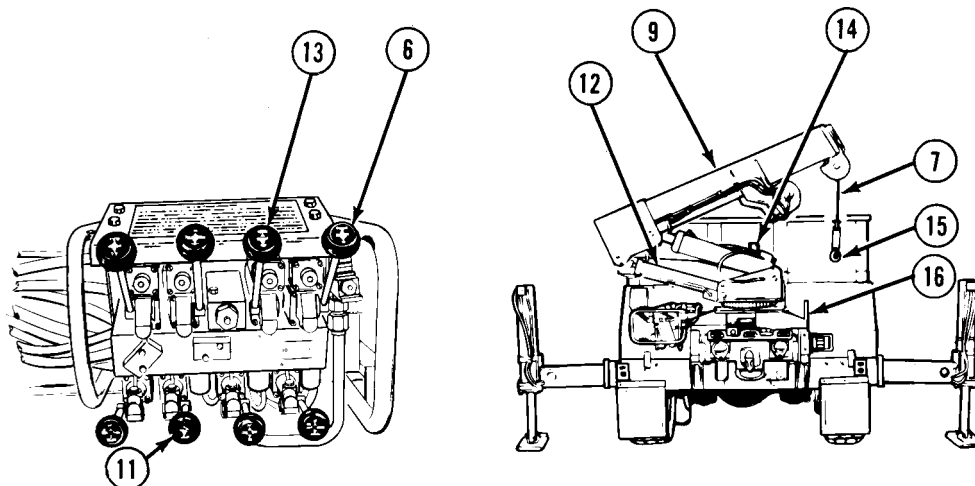
SHUTDOWN CRANE - Continued*Figure 20.*

7. Move BOOM control lever (13) in concert with MAST control lever (11) as required to maintain boom (9) at approximately 45 degrees above horizontal until mast (12) is completely folded down.
8. Move BOOM control lever (13) to DOWN position until boom (9) comes to rest on mast rest pad (14).

CAUTION

Release hook lock before connecting load hook to stowage ring bracket to avoid damage to hook lock.

NOTE

Stowage ring is smallest hole in bracket.

9. Connect load hook (15) to stowage ring bracket (16). Move HOIST control lever (6) in UP position to remove slack from hoist cable (7).

STOW OUTRIGGERS

1. Remove two retaining pins (1) from each outrigger pad (2).

NOTE

Operate left and right outrigger jack (LH O/R JACK and RH O/R JACK) control levers at the same time until both outrigger jack cylinders are out of pads.

STOW OUTRIGGERS - Continued

2. Move left outrigger jack (LH O/R JACK) and right outrigger jack (RH O/R JACK) control levers (3 and 4) to UP position to retract outrigger jack cylinders (5) completely.

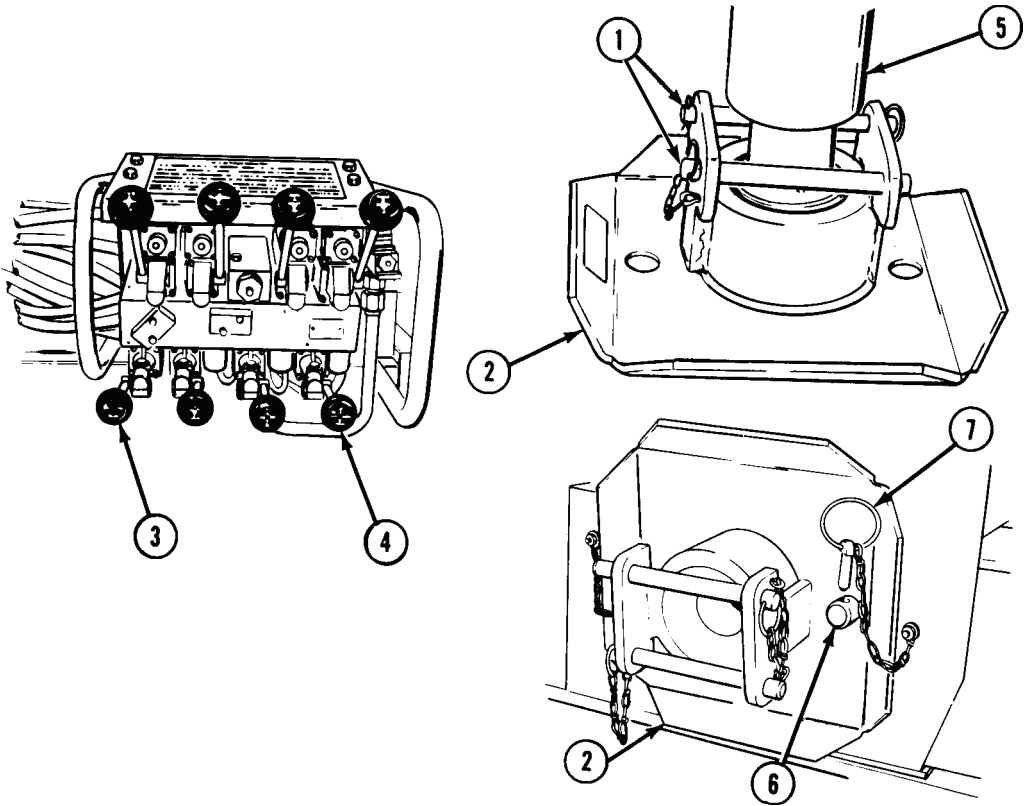
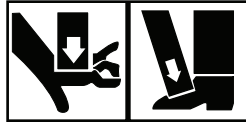

Figure 21.

3. Install two retaining pins (1) into each outrigger pad (2).
4. Stow each outrigger pad (2) on appropriate stud (6).
5. Install safety pins (7) through each stud (6).

STOW OUTRIGGERS - Continued

WARNING



Keep hands and feet clear of outrigger jack cylinders. Failure to comply may result in injury or death to personnel.

6. Move outrigger extension (O/R EXT) control lever (8) to IN position to retract outrigger beams (9) completely.

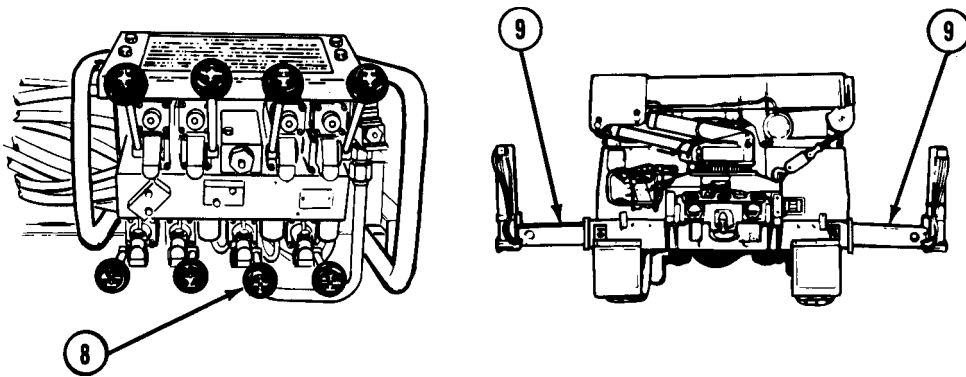

Figure 22.

7. Set ENGINE HIGH IDLE ON/OFF switch (10) to OFF position.

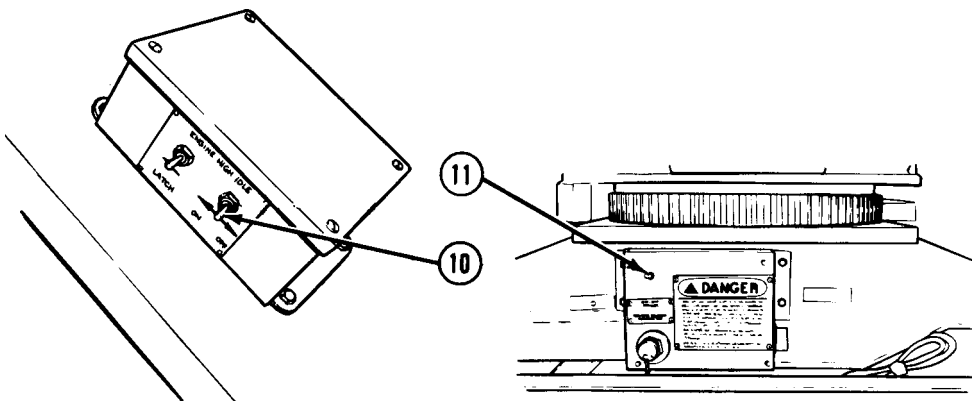

Figure 23.

STOW OUTRIGGERS - Continued

8. Set ON/OFF POWER switch (11) to OFF position.
9. Set PTO ENGAGE switch (12) to OFF position. Indicator light (13) will go out.

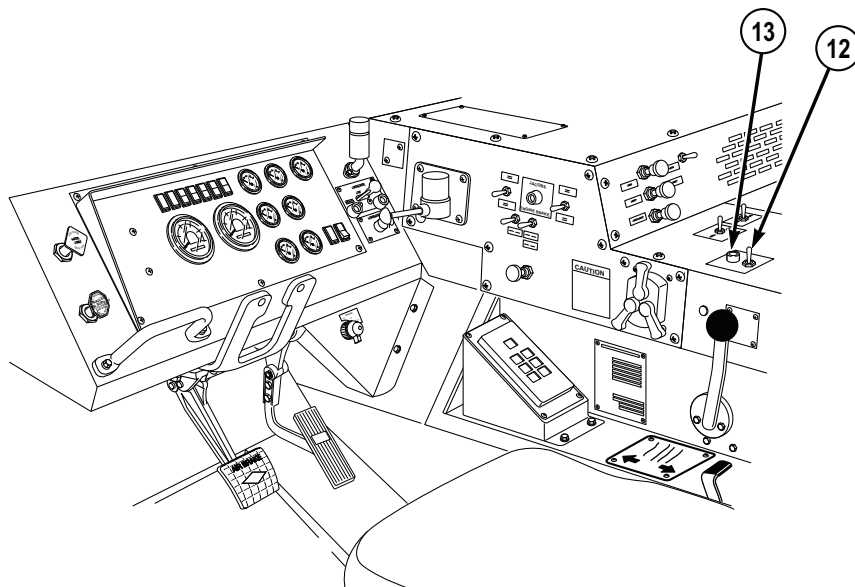

Figure 24.

10. Shut off engine. (WP 0057)

END OF TASK

END OF WORK PACKAGE

**OPERATOR MAINTENANCE
GROVE CRANE OPERATION (REMOTE CONTROL)**

INITIAL SETUP:

Not Applicable

SET UP REMOTE CONTROL UNIT

WARNING



If operator cannot see load during operation, operate crane from REMOTE CONTROL UNIT. Failure to comply may result in injury or death to personnel.

1. Prepare crane for use.
2. Set up outriggers.
3. Jack outriggers.
4. Raise boom to operating position.
5. Remove REMOTE CONTROL UNIT (1) and cable (2) from stowage box (3).

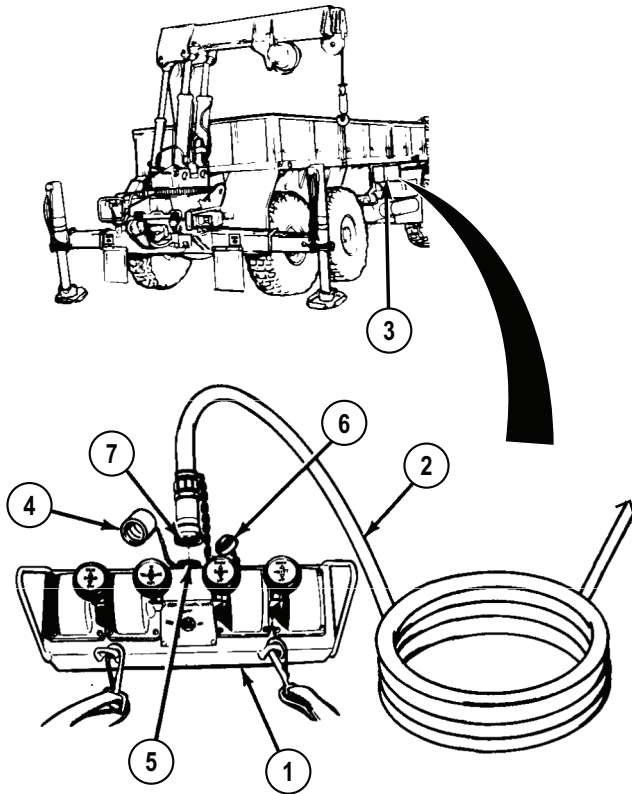
SET UP REMOTE CONTROL UNIT - Continued*Figure 1.*

6. Remove cover (4) and clean any dirt or water from REMOTE CONTROL UNIT receptacle (5).
7. Remove cover (6) and clean any dirt or water from cable plug (7).
8. Connect cable plug (7) to REMOTE CONTROL UNIT receptacle (5).

CONNECT REMOTE CONTROL UNIT TO REAR OUTLET

1. Set ON/OFF power switch (1) on electrical control box (2) to OFF position.

CONNECT REMOTE CONTROL UNIT TO REAR OUTLET - Continued

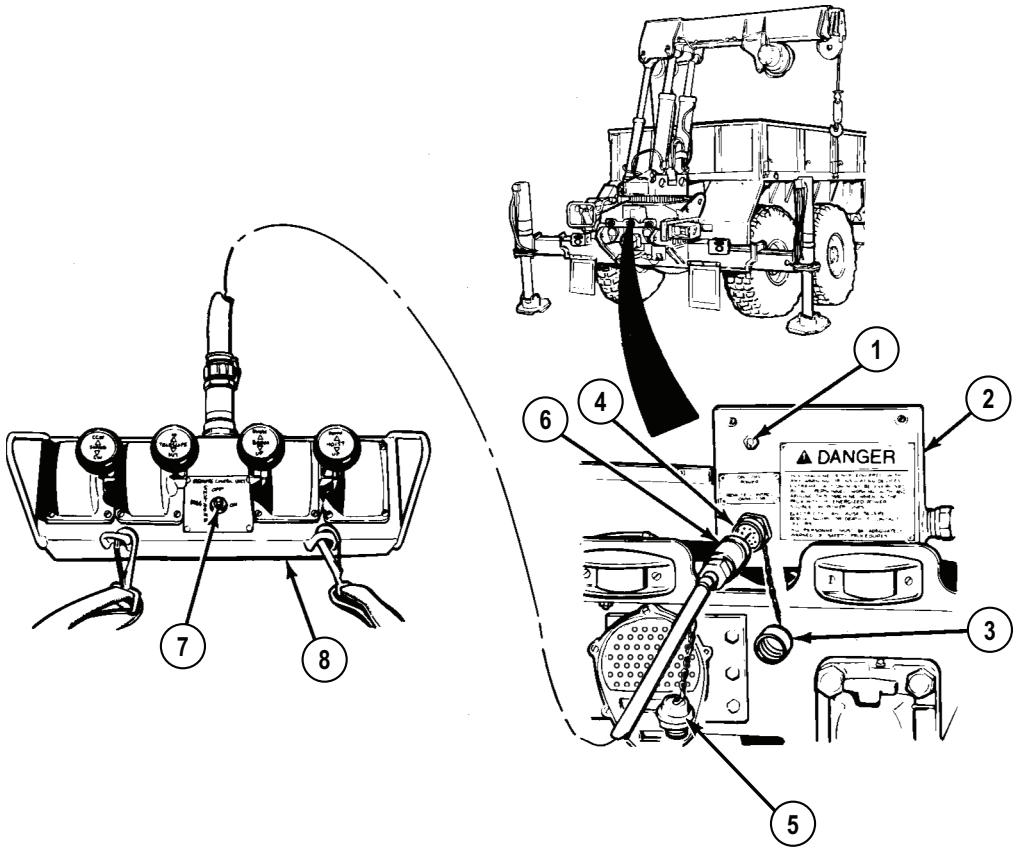

Figure 2.

2. Remove cover (3) and clean any dirt or water from REMOTE CONTROL CONNECTOR outlet (4).
3. Remove cover (5) and clean any dirt or water from cable plug (6).

WARNING

Ensure ON/OFF/MHC-SHUTDOWN power switch is in OFF position prior to connecting REMOTE CONTROL UNIT. Failure to comply may result in injury or death to personnel.

CONNECT REMOTE CONTROL UNIT TO REAR OUTLET - Continued

4. Set ON/OFF MHC-SHUTDOWN power switch (7) on REMOTE CONTROL UNIT (8) to OFF position.
5. Connect cable plug (6) to REMOTE CONTROL CONNECTOR outlet (4).
6. Set ON/OFF POWER switch (1) on electrical control box (2) to ON position.
7. Set ON/OFF MHC-SHUTDOWN power switch (7) on REMOTE CONTROL UNIT (8) to ON position.
8. Operate crane.

CONNECT REMOTE CONTROL UNIT TO FORWARD OUTLET

1. Set ON/OFF power switch (1) on electrical control box (2) to OFF position.

CONNECT REMOTE CONTROL UNIT TO FORWARD OUTLET - Continued

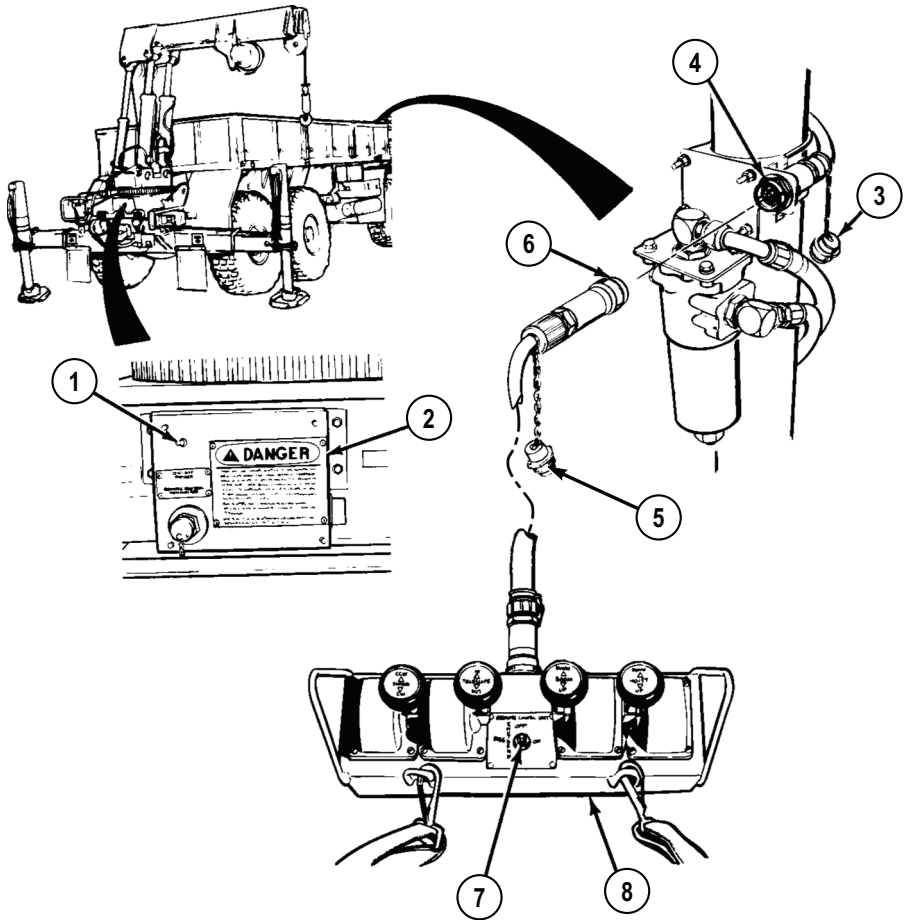

Figure 3.

2. Remove cover (3) and clean any dirt or water from REMOTE CONTROL CONNECTOR outlet (4).
3. Remove cover (5) and clean any dirt or water from cable plug (6).

CONNECT REMOTE CONTROL UNIT TO FORWARD OUTLET - Continued**WARNING**

Ensure ON/OFF/MHC-SHUTDOWN power switch is in OFF position prior to connecting REMOTE CONTROL UNIT. Failure to comply may result in injury or death to personnel.

4. Set ON/OFF MHC-SHUTDOWN power switch (7) on REMOTE CONTROL UNIT (8) to OFF position.
5. Connect cable plug (6) to REMOTE CONTROL CONNECTOR outlet (4).
6. Set ON/OFF POWER switch (1) on electric control box (2) to ON position.
7. Set ON/OFF MHC-SHUTDOWN power switch (7) on REMOTE CONTROL UNIT (8) to ON position.
8. Operate crane.

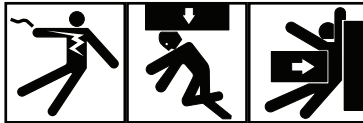
ROTATE AND TELESCOPE BOOM**WARNING**

- When using crane on any vehicle, park vehicle clear of all overhead electrical lines. Keep boom clear of all electrical lines and other obstacles while operating crane. Failure to comply may result in injury or death to personnel.
- Ensure area is clear of personnel prior to moving SWING control lever. Boom should be swung slowly enough so crane operator has complete control. If operator cannot see load during operation, operate crane from REMOTE CONTROL UNIT. Failure to comply may result in injury or death to personnel.
- Operator must keep control of load at all times. If necessary, attach cargo tiedowns to load for control. Failure to comply may result in injury or death to personnel.
- If electrical power fails during crane operation, move switch on REMOTE CONTROL UNIT to SHUTDOWN position. Failure to comply may result in injury or death to personnel.

ROTATE AND TELESCOPE BOOM - Continued**CAUTION**

Boom must be above vehicle sides for clearance. Hitting side of vehicle with boom may cause damage to equipment.

NOTE

Operate control levers with light, even pressure. Moving lever slightly will cause slow movement of crane. Moving lever to full travel will cause faster movement of crane.

1. Move SWING control lever (1) to CW position to move boom (2) clockwise.

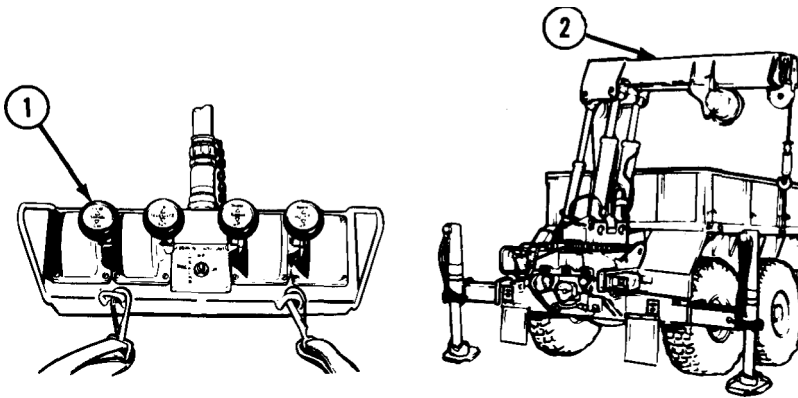

Figure 4.

2. Move SWING control lever (1) to CCW position to move boom (2) counterclockwise.

CAUTION

Keep hook block at least 2 ft. (0.61 m) from end of boom. If hook block hits end of boom it may damage cable or hook block and crane will lose power. Wait six seconds for power to return and check crane for damage.

NOTE

- When crane is overloaded, vehicle overload system will automatically shut off power to telescope boom out, raise boom, or hoist load any higher. Vehicle overload system will also prevent lowering boom. Overload condition can be corrected by lowering load to ground or other supporting surface by using HOIST control lever only.

ROTATE AND TELESCOPE BOOM - Continued

- When telescoping (extending) the boom, the TELESCOPE and HOIST control levers should be operated at the same time to keep hook block at least 2 ft. (0.61 m) from end of boom.
 - Crane movement from one lever may be slower than other when operating two levers together.
3. Move TELESCOPE control lever (3) to OUT position to extend boom (2) and move HOIST control lever (4) to DOWN position to pay out cable (5).

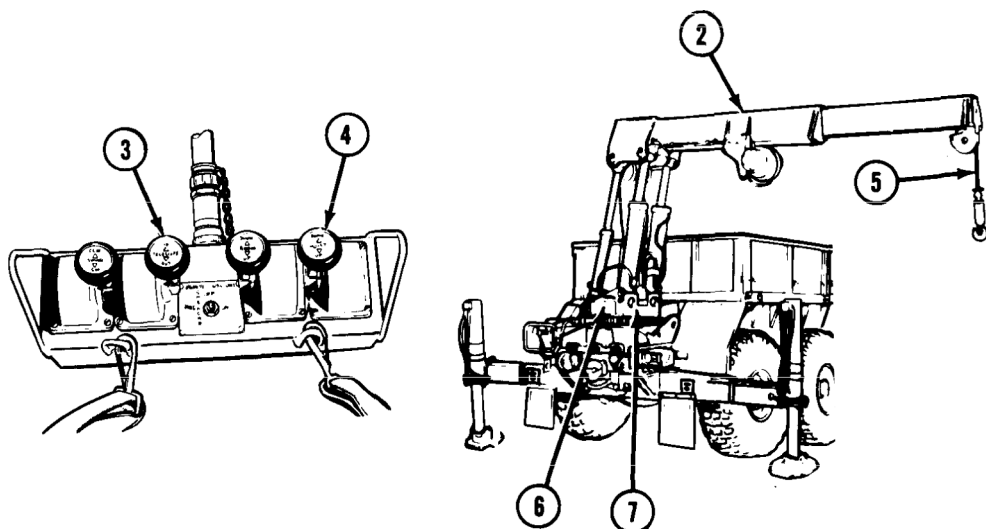
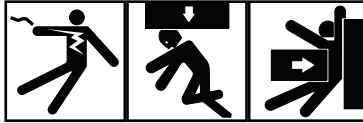

Figure 5.

CAUTION

- Do not go over maximum load rating as shown on RANGE DIAGRAM. Going over load rating could cause damage to equipment.
 - When operating Grove crane, raise boom to approximately 60° angle to pick up maximum load or equipment could be damaged.
4. Refer to RANGE DIAGRAM (6) on turntable panel (7) to raise boom (2) to correct angle before connecting load.

RAISE AND LOWER LOAD**WARNING**

- When using crane on any vehicle, park vehicle clear of all overhead electrical lines. Keep boom clear of all electrical lines and other obstacles while operating crane. Failure to comply may result in injury or death to personnel.
- Ensure area is clear of personnel prior to moving SWING control lever. Boom should be swung slowly enough so crane operator has complete control. If operator cannot see load during operation, operate crane from REMOTE CONTROL UNIT. Failure to comply may result in injury or death to personnel.
- Operator must keep control of load at all times. If necessary, attach cargo tiedowns to load for control. Failure to comply may result in injury or death to personnel.
- If electrical power fails during crane operation, move switch on REMOTE CONTROL UNIT to SHUTDOWN position. Failure to comply may result in injury or death to personnel.

CAUTION

- Do not let cable become slack. Cable may get tangled in drum and damage equipment.
 - Do not drag load sideways on ground. Dragging load could cause damage to equipment.
1. Operate SWING control lever (1) to center end of boom (2) directly over load.

RAISE AND LOWER LOAD - Continued

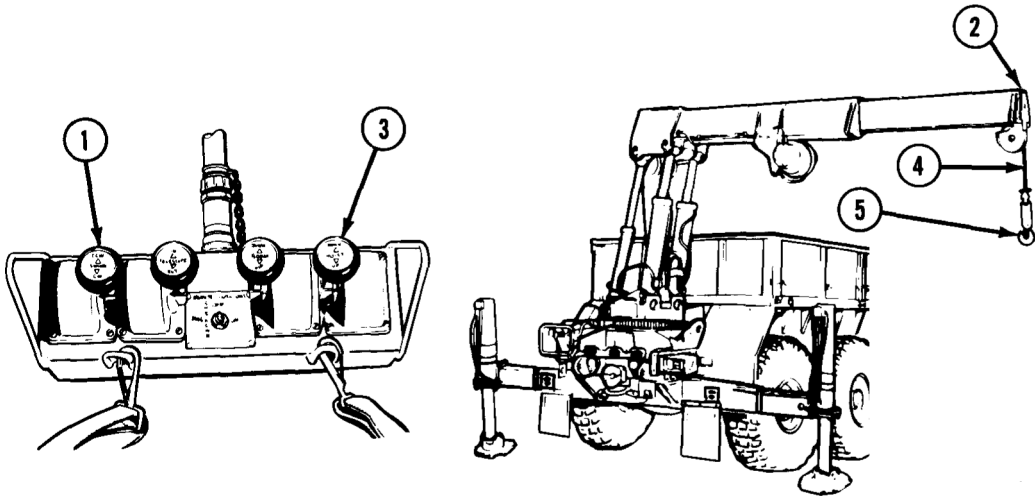

Figure 6.

CAUTION

Release hook lock before connecting load to avoid damage to equipment.

2. Operate HOIST control lever (3) to raise or lower cable (4) and connect load hook (5) to load.

WARNING

- Always wear protective gloves when handling winch cable. Never let cable run through hands. Frayed cables can cut severely. Failure to comply may result in injury or death to personnel.
- Never operate winch with less than five wraps of cable on winch drum. Failure to comply may result in injury or death to personnel.

CAUTION

- Do not jerk HOIST control lever or load will bounce and damage to equipment may occur.
- Do not operate crane with boom below horizontal when there is a load on hook or damage to equipment may occur.

RAISE AND LOWER LOAD - Continued

- Do not go over maximum load limit. Going over maximum load limit will cause electrical shutdown for six seconds or until load is lowered.

NOTE

- For M977, maximum load limit with boom length under 9 ft. (2.75 m) is 4500 lbs (2 043 kg). Maximum load limit with boom extended over 9 ft. (2.75 m) is 2500 lbs (1 135 kg) (refer to RANGE DIAGRAM for more information).
 - For M985 maximum load limit is 5400 lbs (2 452 kg) for entire boom reach (refer to RANGE DIAGRAM for more information).
3. Move HOIST control lever (3) to UP position to lift load. Move BOOM control lever (6) to UP position to raise load higher.

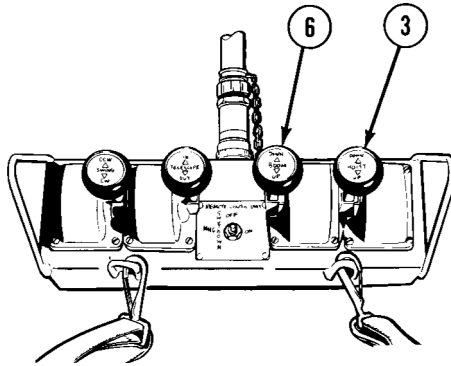
*Figure 7.*

4. Move HOIST control lever (3) to DOWN position to lower load. Move BOOM control lever (6) to DOWN position to lower load further.

SHUT OFF SWITCHES

1. Set ON/OFF/MHC-SHUTDOWN power switch (1) on REMOTE CONTROL UNIT (2) to OFF position.

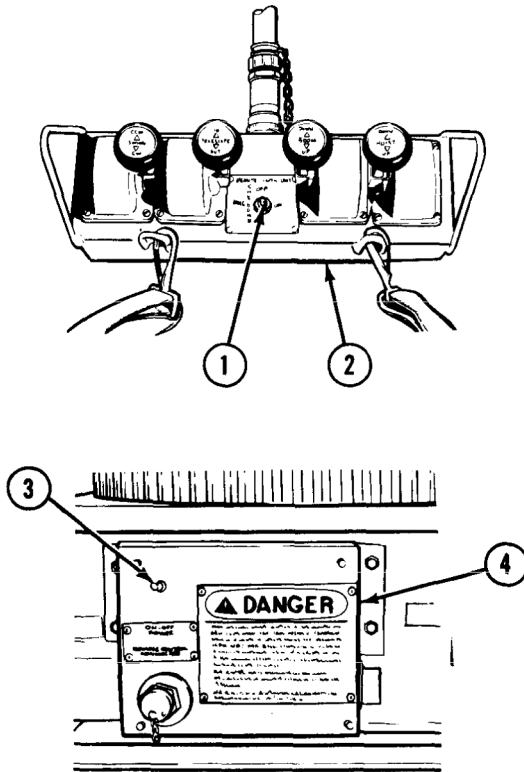
SHUT OFF SWITCHES - Continued*Figure 8.*

2. Set ON-OFF POWER switch (3) on electric control box (4) in OFF position.
3. Disconnect REMOTE CONTROL UNIT (2) from either rear or forward remote-control outlet (as applicable).

DISCONNECT REMOTE CONTROL UNIT FROM REAR OUTLET

1. Disconnect cable plug (1) and install cover (3) on REMOTE CONTROL CONNECTOR outlet (2).

DISCONNECT REMOTE CONTROL UNIT FROM REAR OUTLET - Continued

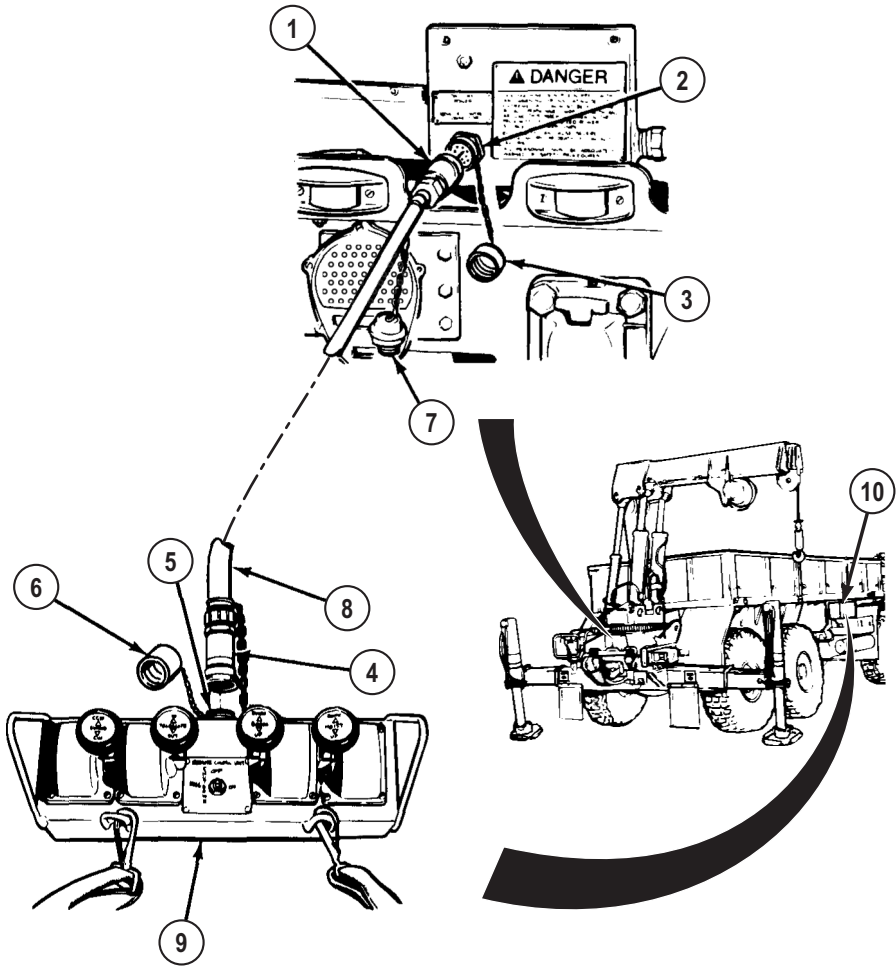

Figure 9.

2. Disconnect cable plug (4) from REMOTE CONTROL UNIT receptacle (5). Install cover (6).
3. Install covers (7) on both ends of cable (8) and coil cable (8) for stowage.
4. Return REMOTE CONTROL UNIT (9) and cable (8) to stowage box (10).
5. Shut down crane.

DISCONNECT REMOTE CONTROL UNIT FROM FORWARD OUTLET

1. Disconnect cable plug (1) and install cover (3) on REMOTE CONTROL CONNECTOR outlet (2).

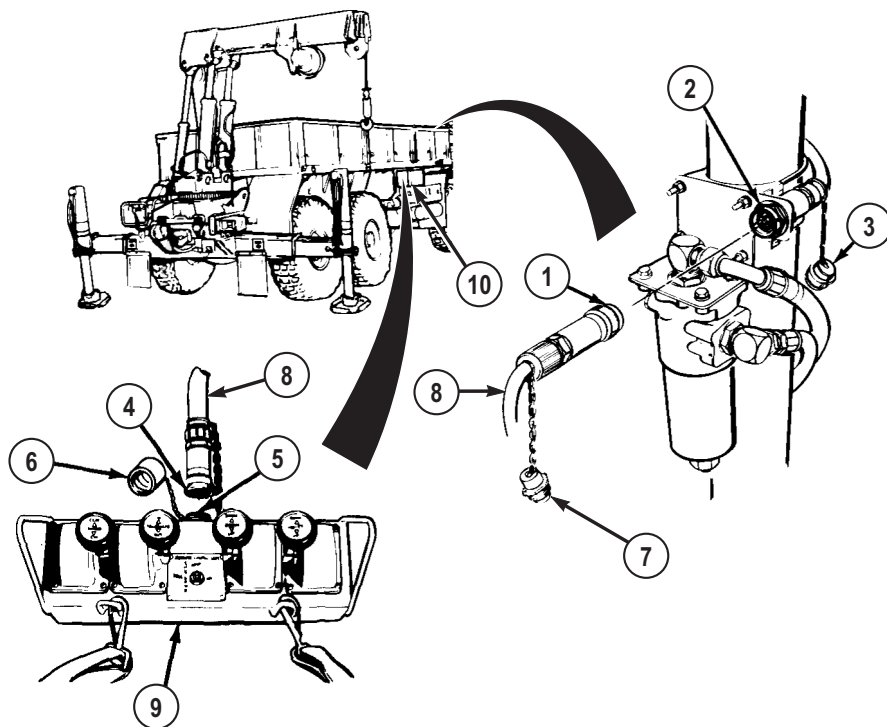

Figure 10.

2. Disconnect cable plug (4) and install cover (6) on REMOTE CONTROL UNIT receptacle (5).
3. Install covers (7) on both ends of cable (8) and coil cable (8) for storage.
4. Return REMOTE CONTROL UNIT (9) and cable (8) to stowage box (10).
5. Shut down crane.

END OF TASK

END OF WORK PACKAGE

OPERATOR MAINTENANCE START ENGINE

INITIAL SETUP:

Not Applicable

START COLD ENGINE

WARNING



Do not start, crank engine, or move vehicle when anyone is near, working on, or working under vehicle. Failure to comply may result in injury or death to personnel.

WARNING



Keep away from moving engine parts, alternator belts, and pulleys while engine is running. Failure to comply may result in injury or death to personnel.

NOTE

- Ensure that 24V battery disconnect switch is set to ON position (WP 0079) before attempting to start engine.
 - Dashboard parking brake indicator will illuminate when PARKING BRAKE control is applied.
1. Pull out PARKING BRAKE control (1).

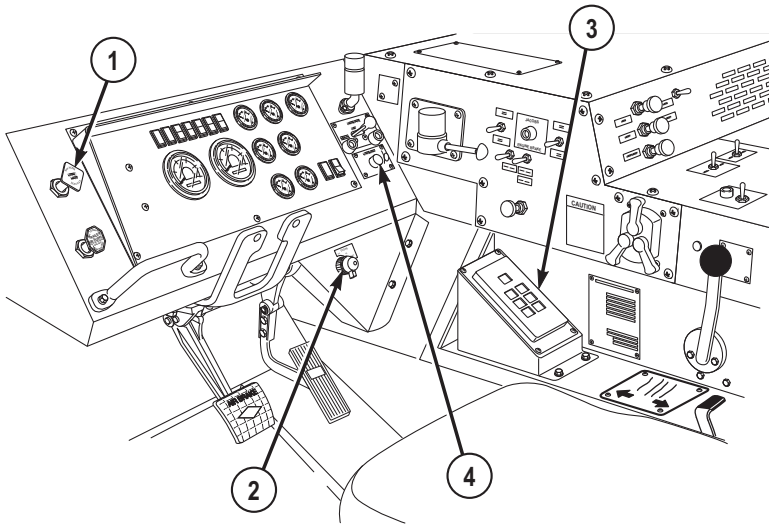
START COLD ENGINE - Continued*Figure 1.*

2. Turn ENGINE switch (2) to ON.
3. Set transmission range selector (3) to N (neutral).

CAUTION

- Do not press ETHER START button more than three times in a single starting attempt. Failure to comply may result in damage to equipment.
- Do not turn ENGINE switch to start position while motor is still running. Failure to comply may result in damage to equipment.
- If engine fails to start, wait 15 seconds before next start attempt to allow motor to cool. Failure to comply may result in damage to equipment.

NOTE

- If outside temperature is above 45°F (7°C), skip to Step (5). If outside temperature is below 45°F (7°C), continue with Step (4).
- Complete Step (4):
 - One time for temperatures between 45°F and 10°F (7°C and -12°C).
 - Two times for temperatures between 10°F and -10°F (-12°C and -23°C).

START COLD ENGINE - Continued

- Three times for temperatures between -10°F and -25°F (-23°C and -32°C).
 - Repeat Steps (4) and (5) up to four times. If engine fails to start after four starting attempts, notify field level maintenance.
 - Under extreme cold temperatures, it may be necessary to press the ETHER START button two or three times in a single starting attempt. Wait approximately three seconds between each press.
4. Press and hold ETHER START button (4) for three seconds, release, and wait three seconds.
 5. Turn ENGINE switch (2) to START for no more than 15 seconds, or until engine starts.

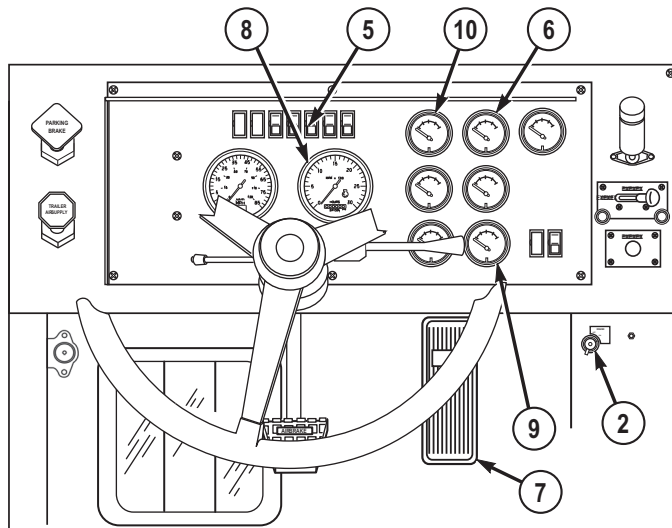
*Figure 2.***NOTE**

- ENGINE switch will spring back to ON position when released.
 - LOW AIR indicator may illuminate and buzzer may sound upon engine start.
6. Release ENGINE switch (2). LOW AIR indicator (5) may light and buzzer may sound.

CAUTION

- Do not turn ENGINE switch to START position while motor is still running. Failure to comply may result in damage to equipment.

START COLD ENGINE - Continued

- If OIL PRESS gauge does not show engine oil pressure within 10 to 15 seconds after starting engine, immediately shut off engine (WP 0057) and notify field level maintenance. Failure to comply may result in damage to equipment.
 - If engine fails to start, repeat Step (3) up to seven times. If engine doesn't start after eight starting attempts, notify field level maintenance.
7. Check that OIL PRESS gauge (6) reads 5 to 10 psi (34 to 69 kPa) at idle.
 8. Press throttle pedal (7) until tachometer (8) reads 800-1000 rpm.
 9. Run engine at 800-1000 rpm for about 5 minutes.

NOTE

Engine idle speed should not read less than 600 rpm or more than 800 rpm when engine is hot.

10. Release throttle pedal (7) and check engine idle speed on tachometer (8).

CAUTION

If red and green needles on AIR PRESS gauge do not read 60 to 120 psi (414 to 827 kPa) after warm-up, shut off engine (WP 0057) and notify field level maintenance. Failure to comply may result in damage to equipment.

11. Check that AIR PRESS gauge (9) reads 60 to 120 psi (414 to 827 kPa). LOW AIR indicator (5) will light and buzzer will sound until both needles reach 60 to 75 psi (414 to 517 kPa).
12. Check that FUEL gauge (10) shows enough fuel to complete mission.

NOTE

WATER TEMP gauge may not show reading at engine idle.

13. Check that WATER TEMP gauge (11) does not read over 210°F (99°C).

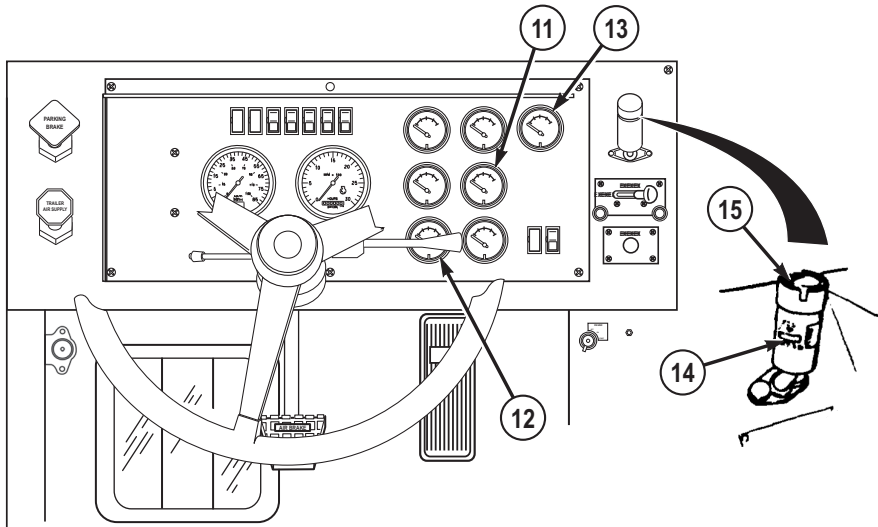
START COLD ENGINE - Continued*Figure 3.*

14. Check that BATTERY gauge (12) reads between 24 and 30 volts.
15. Check that AMPERES gauge (13) shows positive reading.
16. Check that air filter restriction indicator (14) shows yellow.
17. If air filter restriction indicator (14) shows red, press button (15) on top of indicator.
18. If air filter restriction indicator (14) still shows red and/or VACUUM INCHES H₂O window shows 18, shut off engine (WP 0057) and clean air filter elements. (WP 0157)

START WARM ENGINE**WARNING**

Do not start, crank engine, or move vehicle when anyone is near, working on, or working under vehicle. Failure to comply may result in injury or death to personnel.

START WARM ENGINE - Continued**WARNING**

Keep away from moving engine parts, alternator belts, and pulleys while engine is running. Failure to comply may result in injury or death to personnel.

NOTE

- Ensure that 24V battery disconnect switch is set to ON position (WP 0079) before attempting to start engine.
- Dashboard parking brake indicator will illuminate when PARKING BRAKE control is applied.

1. Pull out PARKING BRAKE control (1).

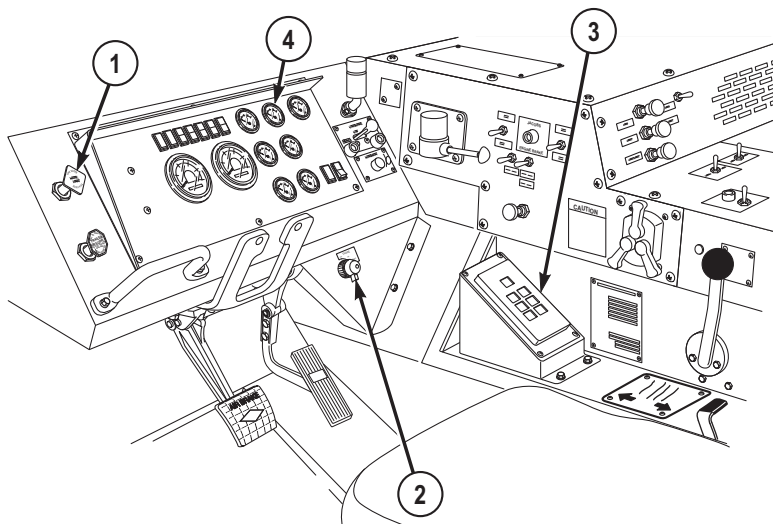

Figure 4.

2. Turn ENGINE switch (2) to ON.
3. Set transmission range selector (3) to N (neutral).
4. Turn ENGINE switch (2) to START for no longer than 10 seconds, or until engine starts.

START WARM ENGINE - Continued**NOTE**

- ENGINE switch will spring back to ON position when released.
 - LOW AIR indicator may illuminate and buzzer may sound upon engine start.
5. Release ENGINE switch (2).

CAUTION

If OIL PRESS gauge does not show engine oil pressure within 10 to 15 seconds after starting engine, shut off engine (WP 0057) immediately and notify field level maintenance. Failure to comply may result in damage to equipment.

NOTE

- Minimum engine oil pressure for safe operation (vehicle moving) is 30 psi (207 kPa).
 - At idle, engine oil pressure can drop as low as 5 psi (34 kPa), this is a normal condition.
 - Engine idle speed should not read less than 600 rpm or more than 800 rpm when engine is hot.
6. Check that engine OIL PRESS gauge (4) indicates normal operating range of 40 to 70 psi (276 to 483 kPa) at 1800 to 2100 rpm.
7. AIR PRESS gauge (5) reads 60 to 120 psi (414 to 827 kPa). LOW AIR indicator (6) will light and buzzer will sound until both needles reach 60 to 75 psi (414 to 517 kPa).

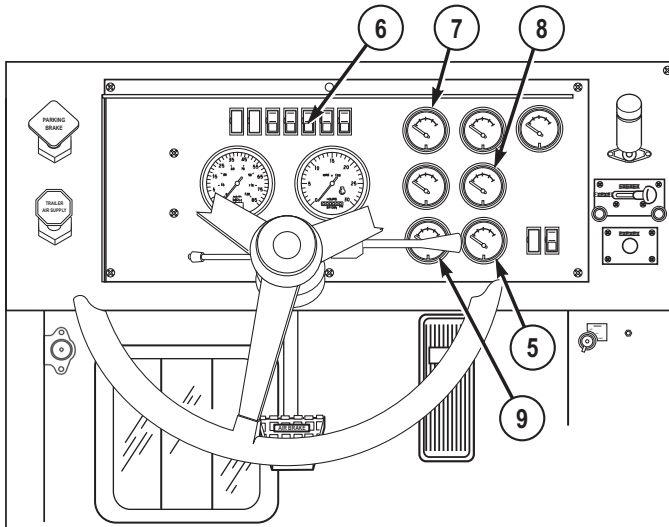
START WARM ENGINE - Continued*Figure 5.*

8. Check that FUEL gauge (7) shows enough fuel to complete mission.

NOTE

WATER TEMP gauge may not show reading at engine idle.

9. Check that WATER TEMP gauge (8) does not read over 230°F (110°C).
10. Check that BATTERY gauge (9) reads between 24 and 30 volts.
11. Check that AMPERES gauge (10) shows positive reading.

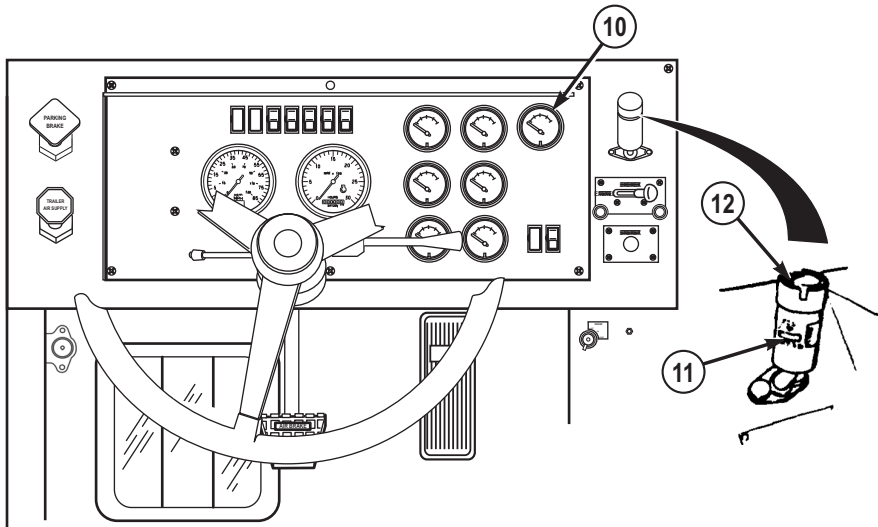
START WARM ENGINE - Continued*Figure 6.*

12. Check that air filter restriction indicator (11) shows yellow.
13. If air filter restriction indicator (11) shows red, press button (12) on top of indicator.
14. If air filter restriction indicator (11) still shows red and/or VACUUM INCHES H₂O window shows 18, shut off engine (WP 0057) and clean air filter elements. (WP 0157)

END OF TASK**END OF WORK PACKAGE**

**OPERATOR MAINTENANCE
OPERATE PARKING BRAKES**

INITIAL SETUP:

Not Applicable

OPERATE PARKING BRAKES**NOTE**

- Vehicle may be equipped with manual parking brake valve (round/black knob) or automatic parking brake valve (square/yellow knob).
 - Automatic parking brake valve shown.
 - Automatic parking brake valve will apply parking brakes when air pressure is 30 psi (207 kPa) or less.
1. Pull out PARKING BRAKE control (1) to apply, parking brake indicator (2) will illuminate.

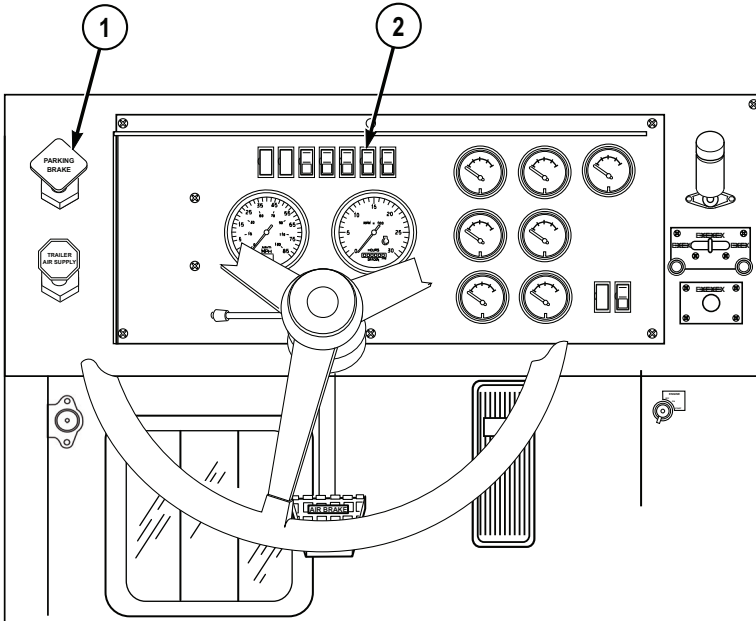
OPERATE PARKING BRAKES - Continued*Figure 1.*

2. Push in PARKING BRAKE control (1) to release, parking brake indicator (2) will go out.

END OF TASK**END OF WORK PACKAGE**

**OPERATOR MAINTENANCE
OPERATE SERVICE BRAKES**

INITIAL SETUP:

Not Applicable

OPERATE SERVICE BRAKES**WARNING**

Do not press service brake treadle hard three or four times in a row. Air supply will be used up and service brakes will not work until air is built up again. Failure to comply may result in injury or death to personnel.

1. Make both needles (red and green) of AIR PRESS gauge (1) read at least 100 psi (690 kPa) before operating vehicle.
2. Push down and hold service brake pedal (2) as needed to slow or stop vehicle.

OPERATE SERVICE BRAKES - Continued

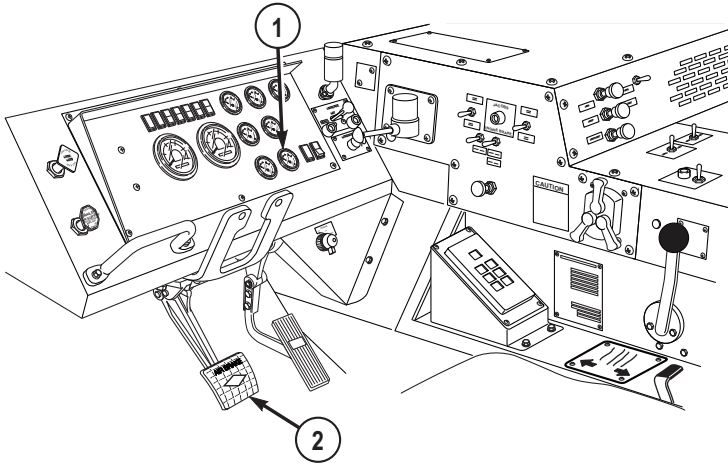

Figure 1.

END OF TASK

END OF WORK PACKAGE

**OPERATOR MAINTENANCE
OPERATE TRAILER BRAKES**

INITIAL SETUP:

Not Applicable

OPERATE TRAILER BRAKES**WARNING**

Trailer handbrake control is used only when testing trailer brakes. Do not use trailer handbrake control while driving or the trailer may skid and jackknife, causing an accident. Failure to comply may result in injury or death to personnel.

1. Slowly pull back trailer handbrake control (1) to test application of trailer brakes.
2. Push trailer handbrake control (1) forward to test release of trailer brakes.

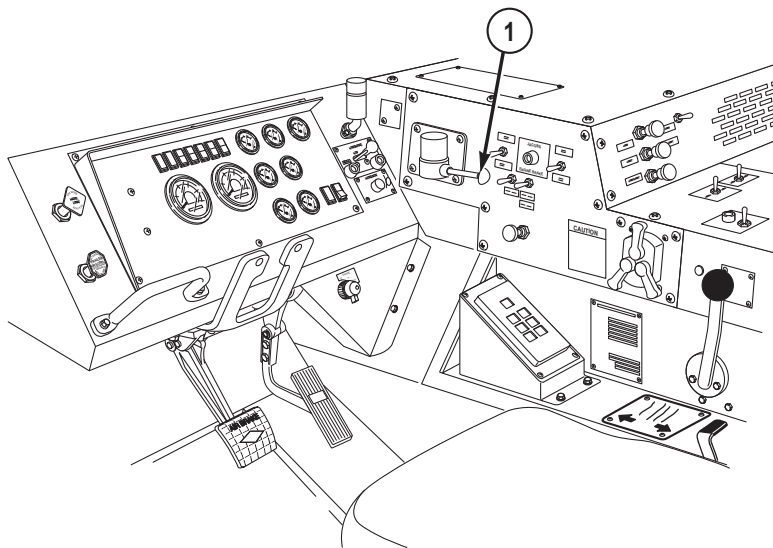
OPERATE TRAILER BRAKES - Continued*Figure 1.***END OF TASK****END OF WORK PACKAGE**

OPERATOR MAINTENANCE OPERATE TRANSMISSION AND TRANSFER CASE

INITIAL SETUP:

Not Applicable

OPERATE ALLISON HD4560 TRANSMISSION

NOTE

- HEMTT A2 series vehicles are equipped with either an Allison model HD4560 (older), or Allison model 4500SP (newer) automatic transmission. The operator is responsible for determining which transmission is applicable to vehicle.
 - The transmission range selector has six buttons and digital display window. The six buttons are: R (reverse), N (neutral), D (drive), up arrow, down arrow, and MODE. The transmission has five forward gears.
 - The MODE button located on the transmission range selector does not perform any operator function.
 - The digital display window on the transmission range selector will display R (reverse), N (neutral), or the number 1 through 5, depending on gear range selected.
 - The lowest gear of any gear range is always first gear.
 - When transmission is set to D (drive), 5 (fifth gear range) is automatically chosen and displayed in the digital display window.
 - When engine brake is activated and vehicle is decelerating, 2 (second gear range) will be displayed in the digital display window.
1. Press the N (neutral) button for the following:
 - a. Start engine. (WP 0044)

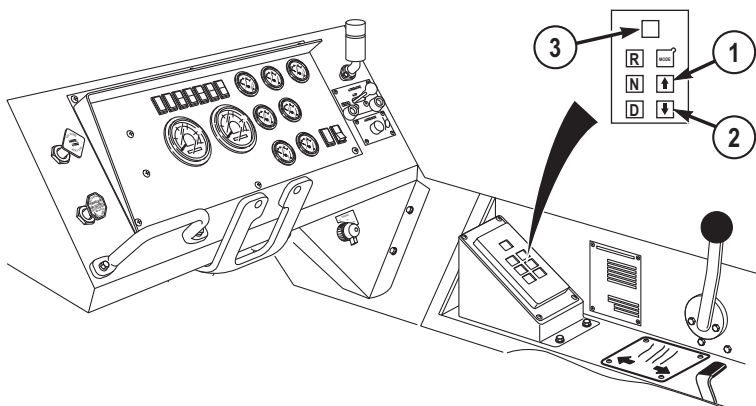
OPERATE ALLISON HD4560 TRANSMISSION - Continued*Figure 1.*

- b. Park vehicle. (WP 0056)
- c. Perform stationary power takeoff.
- d. Shift transfer case.
- e. Operate auxiliary equipment.
2. Press the D (drive) or R (reverse) button depending on directional required:
 - a. R (Reverse):
 - (1) Drive vehicle in reverse. (WP 0051)
 - b. D (Drive):
 - (1) Drive in normal conditions.
 - (2) Drive vehicle forward (WP 0050) from a stop.

NOTE

When setting a new transmission operating range, the top gear of the desired operating range must be chosen and displayed on the transmission range selector digital display.

3. Complete the following if a lower gear range is required:
 - a. Using the up arrow (2) or down arrow (3) buttons, adjust the digital display window (1) until top gear of desired transmission operating range is displayed:

OPERATE ALLISON HD4560 TRANSMISSION - Continued**NOTE**

- Use up or down arrow buttons to adjust gear settings as required.
 - Once the arrow buttons are used, the transmission will not upshift past the gear range displayed in the transmission range selector digital display, but will downshift normally.
 - Press the D (drive) button to return transmission to normal function (using all gears).
- (1) 4 (fourth), 3 (third), or 2 (second) gear range:
- (a) Drive vehicle in off-road conditions. (WP 0053)
 - (b) Drive vehicle in city traffic and on highway. (WP 0052)
 - (c) Haul a heavy load.
 - (d) Drive down moderate grades.
 - (e) Drive in other conditions as needed.
- (2) 1 (first gear range):
- (a) Maximum pulling power is required.
 - (b) Drive vehicle up/down steep grade. (WP 0054)
 - (c) Drive vehicle in slippery conditions. (WP 0055)

OPERATE ALLISON 4500SP TRANSMISSION**CAUTION**

If transmission range selector flashes current range selection while operating vehicle (shift selection is inhibited), DO NOT shut off engine or attempt to change range selection. Shutting off engine may result in the inability to select a drive range at startup, and diagnostic data may be lost. Move vehicle to safe place and notify field level maintenance as soon as possible (refer to limp home/transmission fault for more information). (WP 0105)

NOTE

- HEMTT A2 series vehicles are equipped with either an Allison model HD4560 (older), or Allison model 4500SP (newer) automatic transmission. The operator is responsible for determining which transmission is applicable to vehicle.

OPERATE ALLISON 4500SP TRANSMISSION - Continued

- When transmission oil is below 19°F (-7 C), the only gears available are R (reverse), N (Neutral), and 3 (third gear range) when D (drive) is selected. The remaining gears in D (drive) will not be available until transmission oil in sump warms above 19°F (-7 C).
 - The transmission range selector has six buttons and digital display window. The six buttons are: R (reverse), N (neutral), D (drive), up arrow, down arrow, and MODE. The transmission has five forward gears.
 - The MODE button located on the transmission range selector does not perform any operator function.
 - The digital display window on the transmission range selector will display R (reverse), N (neutral), or the number 1 through 5, depending on gear range selected.
 - The lowest gear of any gear range is always first gear.
 - When transmission is set to D (drive), 5 (fifth gear range) is automatically chosen and displayed in the digital display window.
 - When engine brake is activated and vehicle is decelerating, 2 (second gear range) will be displayed in the digital display window.
1. Press the N (neutral) button (1) for the following:
 - a. Start engine. (WP 0044)

OPERATE ALLISON 4500SP TRANSMISSION - Continued

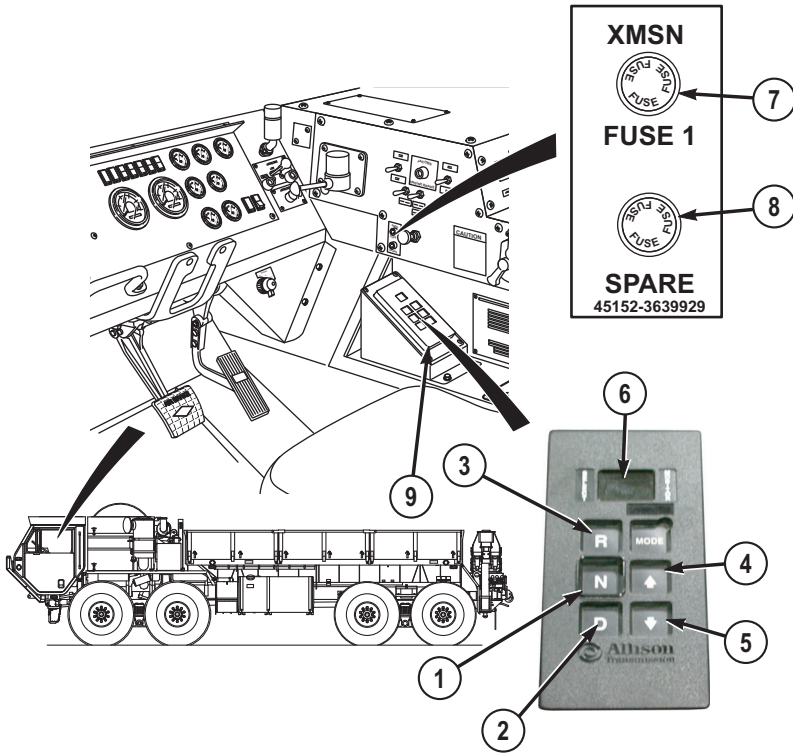

Figure 2.

- b. Park vehicle. (WP 0056)
 - c. Perform stationary power takeoff.
 - d. Shift transfer case.
 - e. Operate auxiliary equipment.
2. Press the D (drive) button (2) or R (reverse) button (3) depending on directional required:
- a. R (Reverse) button (3):
 - (1) Drive vehicle in reverse. (WP 0051)
 - b. D (Drive) (2):
 - (1) Drive in normal conditions.
 - (2) Drive vehicle forward (WP 0050) from a stop.

OPERATE ALLISON 4500SP TRANSMISSION - Continued**NOTE**

When setting a new transmission operating range, the top gear of the desired operating range must be chosen and displayed on the transmission range selector digital display.

3. Complete the following if a lower gear range is required:
 - a. Using the up arrow button (4) or down arrow button (5), adjust the digital display window (6) until top gear of desired transmission operating range is displayed:

NOTE

- Use up or down arrow buttons to adjust gear settings as required.
 - Once the arrow buttons are used, the transmission will not upshift past the gear range displayed in the transmission range selector digital display, but will downshift normally.
 - Press the D (drive) button to return transmission to normal function (using all gears).
- (1) 4 (fourth), 3 (third), or 2 (second) gear range to:
 - (a) Drive vehicle in off-road conditions. (WP 0053)
 - (b) Drive vehicle in city traffic and on highway. (WP 0052)
 - (c) Haul a heavy load.
 - (d) Drive down moderate grades.
 - (e) Drive in other conditions as needed.
 - (2) 1 (first gear range) when:
 - (a) Maximum pulling power is required.
 - (b) Drive vehicle up/down steep grade. (WP 0054)
 - (c) Drive vehicle in slippery conditions. (WP 0055)

NOTE

The XMSN FUSE 1 and SPARE are only used in conjunction with the HP4500SP transmission.

4. Check XMSN FUSE 1 (7), and if blown, replace with SPARE (8) in the event the transmission range selector (9) loses electrical power.

OPERATE ALLISON 4500SP TRANSMISSION - Continued

- a. Upon return, notify field level maintenance if one or both of the fuses were used so they can be replaced, and transmission system can be checked for further problems.

OPERATE TRANSFER CASE

1. Start engine. (WP 0044)

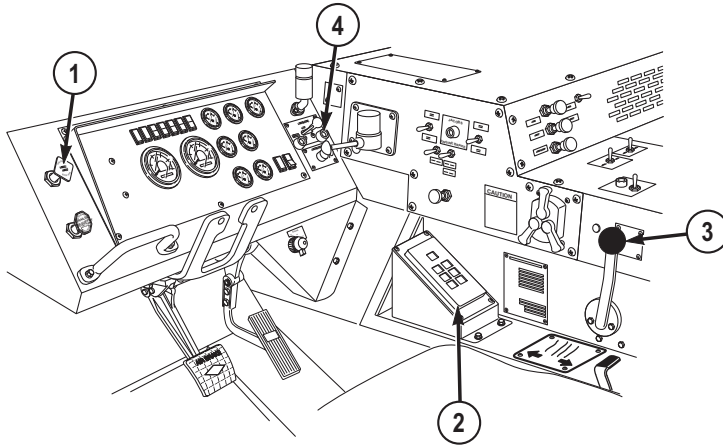

Figure 3.

NOTE

Dashboard parking brake indicator will go out when PARKING BRAKE control is released.

2. Push in PARKING BRAKE control (1).
3. Set transmission range selector (2) to N (neutral).

CAUTION

- Do not force TRANSFER CASE shift lever. Lever may work hard if there is drive line windup. Using excessive force on shift lever may cause damage to shift linkage or change linkage adjustment.
- Do not move TRANSFER CASE shift lever when vehicle is moving, or when transmission is in gear. Severe damage to drive line may result.

4. Select transfer case position.

OPERATE TRANSFER CASE - Continued**NOTE**

If TRANSFER CASE shift lever is hard to move, set transmission range selector to D, then back to N. If transfer case will not shift, refer to troubleshooting procedures. (WP 0140)

5. Set TRANSFER CASE shift lever (3) to H (HI) for highway driving.

NOTE

Selecting L (LO) position automatically selects 8X8 drive in the vehicle traction control system.

6. Set TRANSFER CASE shift lever (3) to L (LO) for off-road driving, 8X8 indicator light (4) will illuminate.

END OF TASK**END OF WORK PACKAGE**

OPERATOR MAINTENANCE
OPERATE ENGINE BRAKE

INITIAL SETUP:

Not Applicable

OPERATE ENGINE BRAKE**WARNING**

Do not use engine brake when vehicle is on slippery surface. If engine brake is used incorrectly, vehicle may skid out of control. Failure to comply may result in injury or death to personnel.

NOTE

Service brakes must be used in addition to engine brake for optimum braking capability.

1. Set JACOBS® ENGINE BRAKE HIGH/LOW switch (1) to LOW.

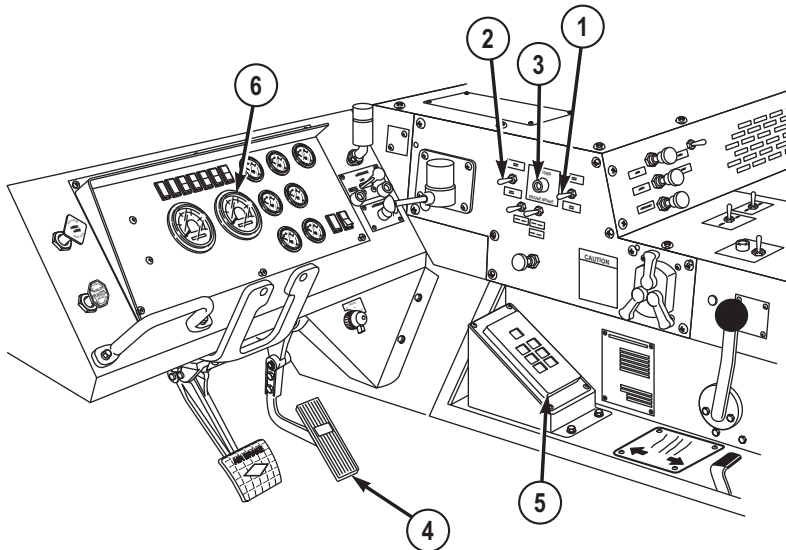
OPERATE ENGINE BRAKE - Continued*Figure 1.*

2. Set JACOBS® ENGINE BRAKE ON/OFF switch (2) to ON. JACOBS® ENGINE BRAKE indicator light (3) will come on.
3. Lift foot off throttle pedal (4). Engine brake will automatically slow vehicle.
4. If too much braking occurs, set transmission range selector (5) to a higher range.
5. If more braking is required, set JACOBS® ENGINE BRAKE HIGH/LOW switch (1) to HIGH.

NOTE

Engine brake operates best when engine speed is between 1650 and 2100 rpm.

6. Check that tachometer (6) reads between 1650 and 2100 rpm whenever engine brake is used.

END OF TASK**END OF WORK PACKAGE**

OPERATOR MAINTENANCE DRIVE VEHICLE FORWARD

INITIAL SETUP:

Not Applicable

PREPARE VEHICLE

NOTE

If vehicle has less than 500 miles (805 km), check controls and indicators often during operation and listen for unusual noises or vibrations. Notify field level maintenance of any problems.

1. Remove and stow wheel chocks. (WP 0077)
2. Ensure cargo body end panels are in place.
3. Ensure cargo body side panels are secure. (WP 0041)
4. Ensure grove crane, outriggers, and outrigger pads are secured in stowed position. (WP 0042)
5. Ensure all cargo in cargo body is secured.
6. Adjust air-ride seat and mirrors as needed. (WP 0080)
7. Adjust four-point seatbelt as needed. (WP 0081)
8. Start engine. (WP 0044)
9. Turn on lights as required.

WARNING



Do not press service brake treadle hard three or four times in a row. Air supply will be used up and service brakes will not work until air is built up again. Failure to comply may result in injury or death to personnel.

10. Ensure both needles (red and green) AIR PRESS gauge (1) read at least 100 psi (690 kPa) before driving vehicle.

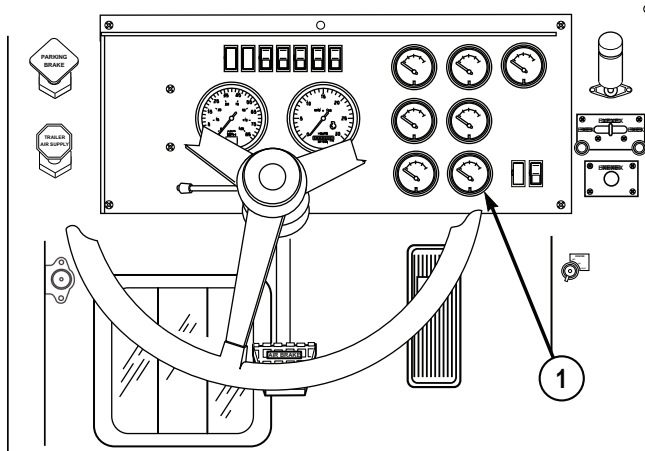
PREPARE VEHICLE - Continued*Figure 1.***DRIVE VEHICLE FORWARD**

1. Drive vehicle in city traffic and on highway. (WP 0052)
2. Drive vehicle in off-road conditions. (WP 0053)
3. Drive vehicle in slippery conditions. (WP 0055)
4. Drive vehicle up/down steep grade. (WP 0054)

END OF TASK**END OF WORK PACKAGE**

OPERATOR MAINTENANCE DRIVE VEHICLE IN REVERSE

INITIAL SETUP:

Personnel Required

Operator and Assistant - - - (2)

PREPARE VEHICLE

1. Remove and stow wheel chocks.
2. Adjust air-ride seat and mirrors as needed. (WP 0080)
3. Adjust four-point seatbelt as needed. (WP 0081)
4. Start engine. (WP 0044)
5. Turn on lights as required.

DRIVE VEHICLE IN REVERSE

WARNING



Do not press service brake treadle hard three or four times in a row. Air supply will be used up and service brakes will not work until air is built up again. Failure to comply may result in injury or death to personnel.

1. Make sure both needles (red and green) on AIR PRESS gauge (1) read at least 100 psi (690 kPa) before driving vehicle.

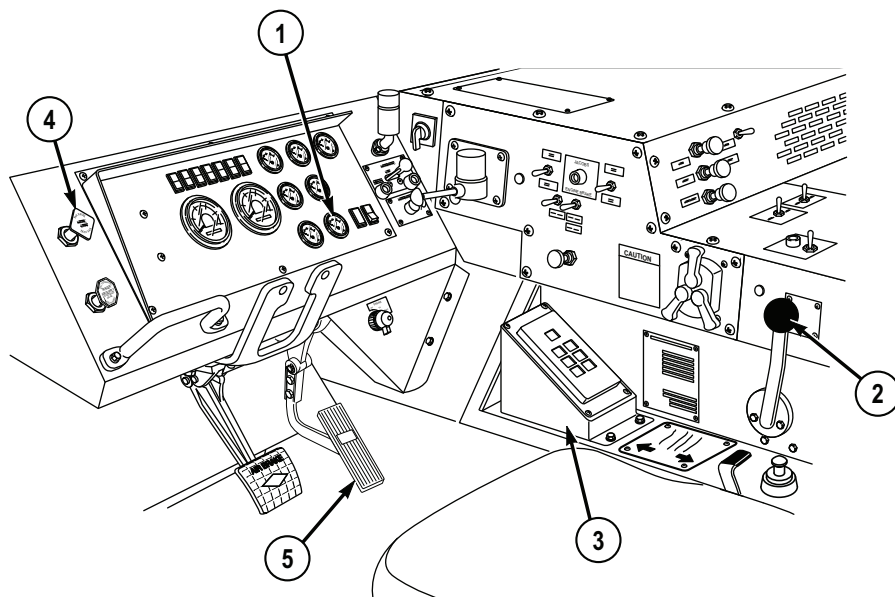
DRIVE VEHICLE IN REVERSE - Continued*Figure 1.***WARNING**

Driver has limited vision to rear. Ground guide is required when driving vehicle in reverse. Failure to comply may result in injury or death to personnel.

CAUTION

Do not move TRANSFER CASE shift lever when vehicle is moving or when transmission is in gear. Severe damage to drive line may result.

2. Set TRANSFER CASE shift lever (2) to HI.

NOTE

Reverse alarm will not sound if blackout lighting is selected.

3. Set transmission range selector (3) to R (reverse).

DRIVE VEHICLE IN REVERSE - Continued**NOTE**

Dashboard parking brake indicator will go out when PARKING BRAKE control is released.

4. Push in PARKING BRAKE control (4).
5. Slowly apply throttle pedal (5).
6. Follow direction from ground guide (as required).

CAUTION

Do not hold steering wheel at full left or full right position for longer than 10 seconds. Oil overheating and pump damage may result.

7. Accelerate, brake, and steer as required.

END OF TASK**END OF WORK PACKAGE**

**OPERATOR MAINTENANCE
DRIVE VEHICLE IN CITY TRAFFIC AND ON HIGHWAY**

INITIAL SETUP:

Not Applicable

OPERATE VEHICLE

WARNING



Speed limits posted on curves reflect speeds that are considered safe for automobiles. Heavy vehicles with a high center of gravity can roll over at these speed limits. Use care and reduce your speed below the posted limit prior to entering a curve. Failure to comply may result in injury or death to personnel.

CAUTION

Do not move TRANSFER CASE shift lever when vehicle is moving or when transmission is in gear. Severe damage to drive line will result.

1. Set TRANSFER CASE shift lever (1) to HI.

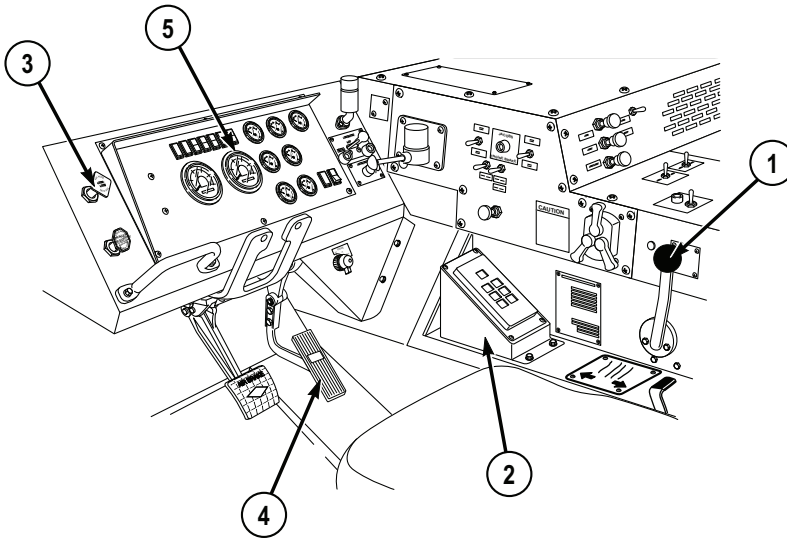
OPERATE VEHICLE - Continued*Figure 1.*

2. Set transmission range selector (2) to D (drive).

NOTE

Dashboard parking brake indicator will go out when PARKING BRAKE control is released.

3. Push in PARKING BRAKE control (3).

CAUTION

Maximum no-load governed engine speed is approximately 2250 rpm. Do not let engine speed go above this figure. Under full load, governed speed is approximately 2100 rpm. If engine speed goes above governed speeds, serious engine damage can result.

4. Slowly depress throttle pedal (4) until vehicle reaches desired speed. Tachometer (5) should read 1650 to 2100 rpm.

CAUTION

Do not hold steering wheel at full left or full right position for longer than 10 seconds. Power steering oil can overheat and pump can be damaged.

5. Accelerate, brake, and steer as required.

OPERATE VEHICLE - Continued**NOTE**

Check system gauges often during vehicle operation. If gauges read other than normal, stop engine and troubleshoot problem.

6. Check that FUEL gauge (6) shows enough fuel to complete mission.

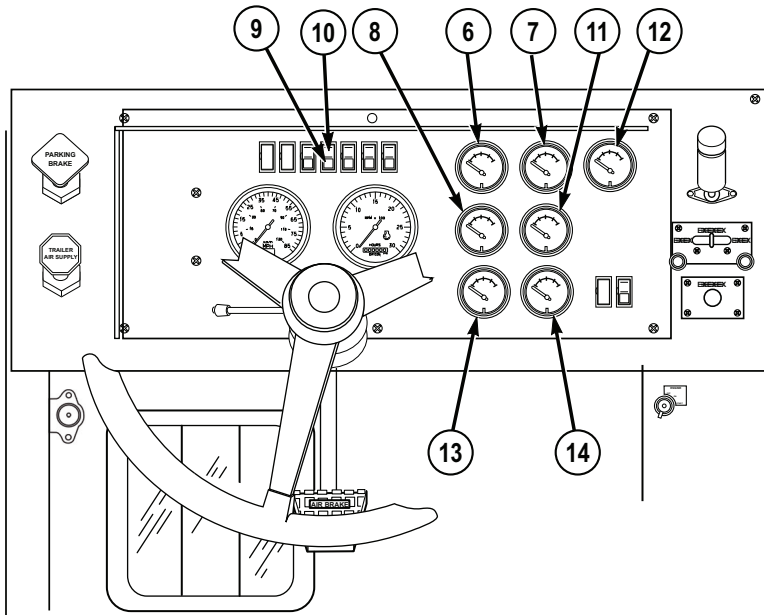

Figure 2.

7. Check that OIL PRESS gauge (7) reads 40 to 70 psi (276 to 483 kPa).
8. If OIL PRESS gauge (7) reads over 70 psi (483 kPa) or lower than 28 psi (193 kPa), park vehicle (WP 0056), shut off engine (WP 0057), and notify field level maintenance.
9. Check that TRANS TEMP (transmission temperature) gauge (8) reads 160 to 220°F (71 to 104°C).
10. If TRANS TEMP indicator (9) illuminates (red), this indicates that the transmission temperature has reached 250°F (121°C). Park vehicle (WP 0056) and allow transmission to cool. Notify field level maintenance upon completion of mission.

CAUTION

If vehicle is equipped with Allison 4500 SP transmission, and transmission range selector flashes current range selection while operating vehicle (shift selection is inhibited), DO NOT SHUT DOWN

OPERATE VEHICLE - Continued

ENGINE OR FURTHER ATTEMPT TO CHANGE TRANSMISSION RANGE SELECTION. Shutting down engine may result in inability of selecting a drive range at engine startup (vehicle will be unable to move), and diagnostic data will be lost. Move vehicle to safe place for maintenance or perform Limp Home/Transmission Fault Emergency Procedures. (WP 0105)

11. If TRANS CHECK indicator (10) illuminates (yellow), there is a potential problem with the transmission and/or the transmission may need to be serviced. Check for correct oil level and/or high transmission oil temperature. If indicators are normal, continue mission and notify field level maintenance as soon as possible.
12. Check that WATER TEMP gauge (11) reads 180 to 200° F (82 to 93° C).
13. If WATER TEMP gauge (11) reads over 210°F (99° C), idle engine until water temperature cools. If water does not cool, shut off engine (WP 0057) and notify field level maintenance.
14. Check that AMPERES gauge (12) reads about zero.
15. Check that BATTERY gauge (13) reads 24 to 28 volts.
16. Check that AIR PRESS gauge (14) red and green needles read 100 to 120 psi (690 to 827 kPa).
17. If OIL-WATER indicator (15) illuminates (red) and buzzer sounds, park vehicle (WP 0056) as soon as possible and notify field level maintenance.

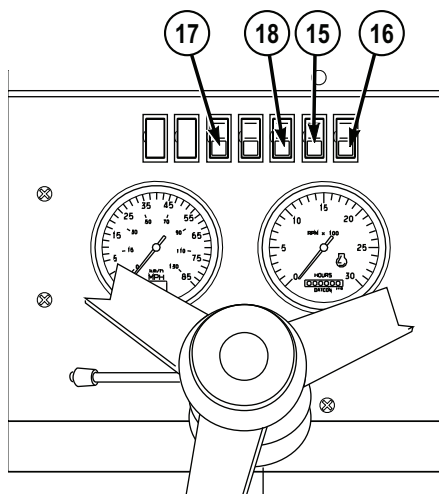

Figure 3.

OPERATE VEHICLE - Continued

18. If CHECK GAUGES indicator (16) illuminates (amber), this is a warning to the operator that a potential engine damaging condition has been detected. Check gauges, if all indicate normal condition, complete mission. Notify field level maintenance upon completion of mission.
19. If CHECK ENGINE indicator (17) illuminates (amber), engine must be serviced by field level maintenance as soon as possible.
20. If LOW AIR indicator (18) illuminates (red), perform immediate action for loss of air supply system pressure emergency procedures. (WP 0083)

END OF TASK**END OF WORK PACKAGE**

OPERATOR MAINTENANCE DRIVE VEHICLE IN OFF-ROAD CONDITIONS

INITIAL SETUP:

Not Applicable

DRIVE VEHICLE IN OFF-ROAD CONDITIONS

CAUTION

Do not move TRANSFER CASE shift lever when vehicle is moving or when transmission is in gear. Severe damage to drive line may result.

NOTE

8x8 DRIVE indicator (WP 0021) will illuminate when TRANSFER CASE shift lever is positioned to L (LO).

1. Set TRANSFER CASE shift lever (1) to L (LO).

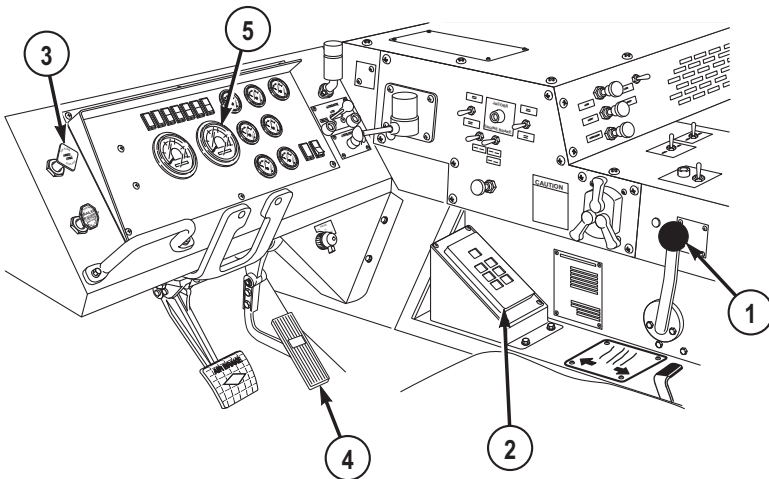

Figure 1.

2. Set transmission range selector (2) to 2 (2nd gear range) or 1 (1st gear range), (WP 0048) depending on ground condition.

DRIVE VEHICLE IN OFF-ROAD CONDITIONS - Continued**NOTE**

Dashboard parking brake indicator will go out when PARKING BRAKE control is released.

3. Push in PARKING BRAKE control (3).

CAUTION

Never let engine exceed maximum no-load governed engine speed (approximately 2250 rpm) or maximum governed engine speed under load (approximately 2100 rpm). If engine is allowed to go over governed engine speeds, serious engine damage may result.

4. Slowly depress throttle pedal (4) until vehicle reaches desired speed. Tachometer (5) should read 1650 to 2100 rpm.

CAUTION

Do not hold steering wheel at full left or full right position for longer than 10 seconds. Power steering oil can overheat and pump may be damaged.

5. Accelerate, brake, and steer as required.

END OF TASK**END OF WORK PACKAGE**

OPERATOR MAINTENANCE DRIVE VEHICLE UP/DOWN STEEP GRADE

INITIAL SETUP:

Not Applicable

DRIVE VEHICLE UP STEEP GRADE

NOTE

- When idling on grades of 40% or greater, OIL-WATER indicator may illuminate and alarm sound indicating engine oil pressure has dropped below acceptable limits. If this condition occurs, slowly increase engine speed until OIL-WATER indicator and alarm go out. Discontinue idling on grade if OIL-WATER indicator and alarm fail to go out upon reaching 1900 RPM.
- When driving or idling on grades of 40% or greater, maintain engine speed at or above 1200 RPM.

Press and hold throttle pedal (1) all the way down as vehicle moves up grade. Transmission will automatically downshift gears as needed.

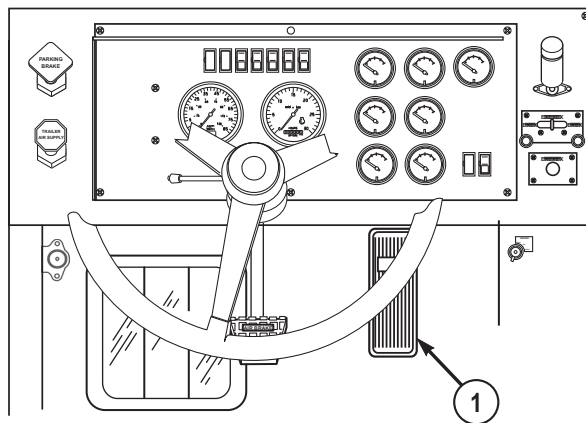

Figure 1.

DRIVE VEHICLE DOWN STEEP GRADE**CAUTION**

- Do not allow speed to go above 2100 RPM when driving downhill, or damage to engine can result.
- Engine brake operates best when engine speed is between 1650 and 2100 RPM. Transmission torque converter lockup valve may disengage below 1650 RPM resulting in loss of engine power.

NOTE

- When idling on grades of 40% or greater, OIL-WATER indicator may illuminate and alarm sound indicating engine oil pressure has dropped below acceptable limits. If this condition occurs, slowly increase engine speed until OIL-WATER indicator and alarm go out. Discontinue idling on grade if OIL-WATER indicator and alarm fail to go out upon reaching 1900 RPM.
 - When idling on grades of 40% or greater, maintain engine speed at or above 1200 RPM.
1. Set transmission range selector (1) to lower range as needed to keep engine speed on tachometer (2) between 1650 and 2100 RPM.

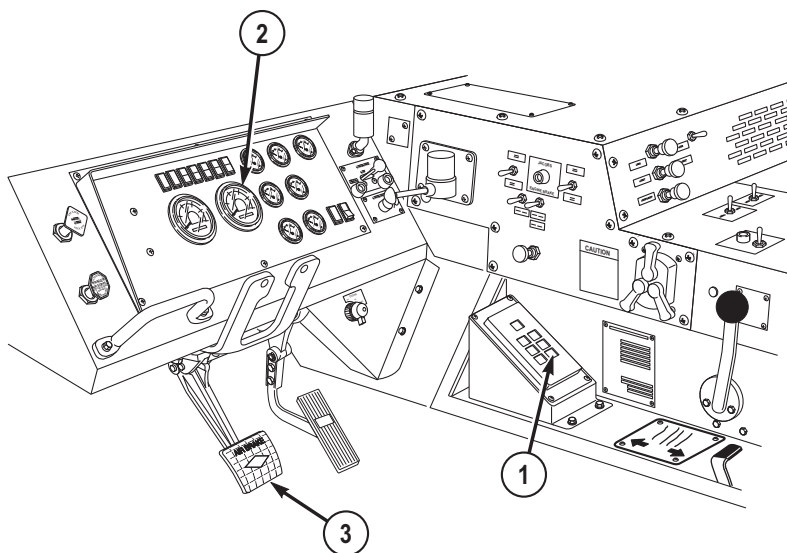
*Figure 2.*

DRIVE VEHICLE DOWN STEEP GRADE - Continued**WARNING**

Do not press service brake treadle hard three or four times in a row. Air supply will be used up and service brakes will not work until air is built up again. Failure to comply may result in injury or death to personnel.

2. Use service brake pedal (3) as needed to control vehicle speed.
3. Operate engine brake (WP 0049) as required.

END OF TASK**END OF WORK PACKAGE**

**OPERATOR MAINTENANCE
DRIVE VEHICLE IN SLIPPERY CONDITIONS**

INITIAL SETUP:

Not Applicable

OPERATE VEHICLE**CAUTION**

Do not shift TRACTION CONTROL lever while vehicle is moving.
Damage to drive line may result.

NOTE

After TRACTION CONTROL lever is shifted, let vehicle creep forward several feet to allow shift collars to fully engage.

1. If TRANSFER CASE shift lever (1) is set to LO, 8X8 DRIVE is automatically engaged and indicator light (4) will illuminate. Set TRACTION CONTROL lever (2) to INTER-AXLE DIFF LOCK. Indicator light (3) will illuminate.

OPERATE VEHICLE - Continued

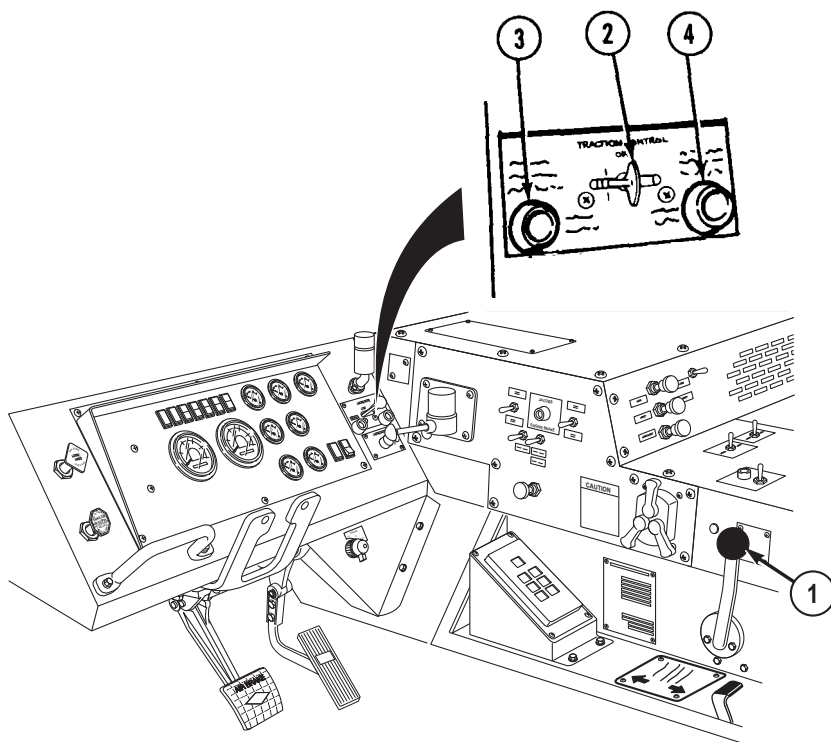

Figure 1.

2. If TRANSFER CASE shift lever (1) is set to HI, set TRACTION CONTROL lever (2) to 8X8 DRIVE. Indicator light (4) will illuminate.

CAUTION

Do not shift TRACTION CONTROL lever while vehicle is moving.
Damage to drive line may result.

NOTE

After TRACTION CONTROL lever is set to OFF position, let vehicle creep forward several feet to allow shift collars to fully disengage.

OPERATE VEHICLE - Continued

3. When vehicle gets good traction again, stop vehicle and set TRACTION CONTROL lever (2) to OFF.

END OF TASK

END OF WORK PACKAGE

OPERATOR MAINTENANCE PARK VEHICLE

INITIAL SETUP:

Not Applicable

OPERATE VEHICLE

1. Lift foot off throttle pedal (1). Let automatic downshifting of transmission slow vehicle.

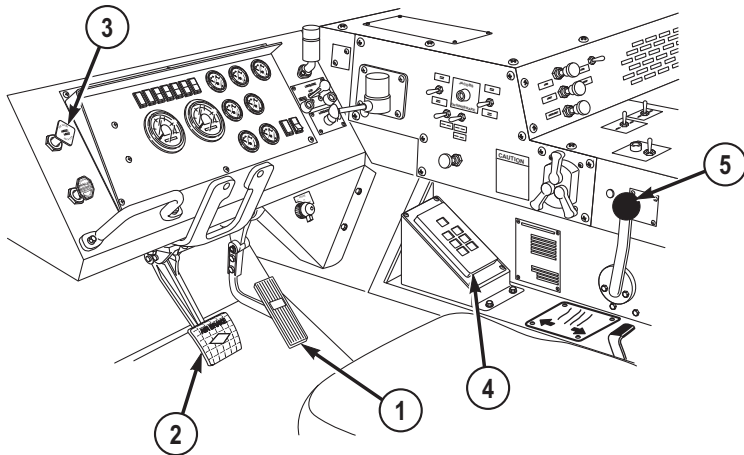

Figure 1.

WARNING



Do not press service brake treadle hard three or four times in a row. Air supply will be used up and service brakes will not work until air is built up again. Failure to comply may result in injury or death to personnel.

2. Push down on service brake pedal (2) until vehicle comes to complete stop.

OPERATE VEHICLE - Continued**NOTE**

Dashboard parking brake indicator illuminates when PARKING BRAKE control is applied.

3. Pull out PARKING BRAKE control (3).
4. Set transmission range selector (4) to N (neutral).
5. Leave TRANSFER CASE shift lever (5) set to HI or LO.
6. Align front tires in straight-ahead position.
7. Install wheel chocks (WP 0077) as required.

END OF TASK**END OF WORK PACKAGE**

OPERATOR MAINTENANCE SHUT OFF ENGINE

INITIAL SETUP:

Not Applicable

SHUT OFF ENGINE

1. Park vehicle (WP 0056).

CAUTION

Before shutting down engine, run at reduced speed (800 to 1000 rpm) at no-load for three to five minutes to allow turbocharger to slow down and cool off. Turbocharger may be damaged if not allowed to cool off.

2. Push down and hold throttle pedal (1) until tachometer (2) reads 800 to 1000 rpm for three to five minutes.

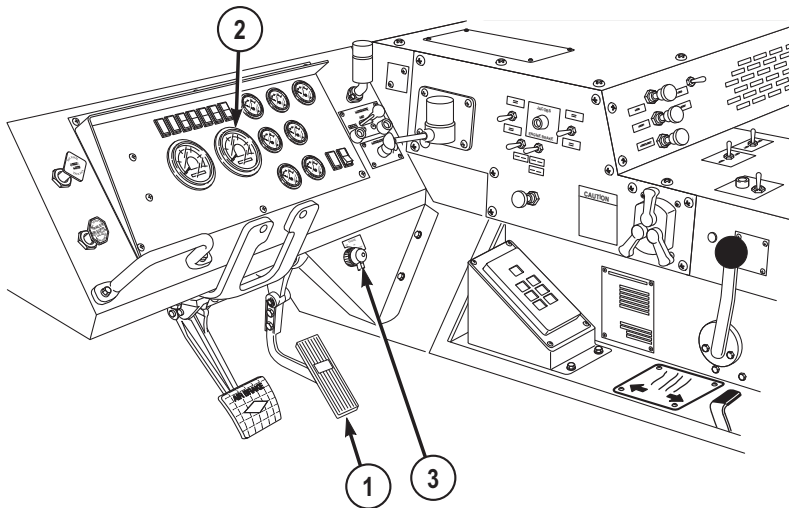

Figure 1.

3. Lift foot off throttle pedal (1).
4. Turn ENGINE switch (3) to OFF.

SHUT OFF ENGINE - Continued**CAUTION**

Failure to place light switches in OFF position when vehicle is not in use may cause battery and/or vehicle damage.

5. Turn off lights as required.
6. Turn 24V battery disconnect switch (4) to OFF position. (WP 0079)

END OF TASK**END OF WORK PACKAGE**

OPERATOR MAINTENANCE OPERATE ARCTIC ENGINE HEATER

INITIAL SETUP:

Not Applicable

WARNING



CARBON MONOXIDE (EXHAUST GAS) CAN CAUSE DEATH.

- Carbon monoxide is a colorless, odorless, **DEADLY POISONOUS** gas that, when breathed, deprives body or oxygen and causes **SUFFOCATION**. Breathing air with carbon monoxide produces symptoms of headache, dizziness, loss of muscular control, a sleepy feeling, and coma. Permanent **BRAIN DAMAGE** or death can result from heavy exposure. Carbon monoxide occurs in the exhaust fumes of fuel-burning heaters and internal combustion engines. Carbon monoxide can become dangerously concentrated under conditions of no ventilation. Precautions **MUST** be followed to ensure personnel are safe whenever personnel heaters or engine is operated for any purpose. Failure to comply may result in injury or death to personnel.
- **DO NOT** operate engine in a closed place without proper ventilation. Failure to comply may result in injury or death to personnel.
- Do not drive vehicle with inspection plates, cover plates, or engine compartment covers removed unless necessary for maintenance purposes. Failure to comply may result in injury or death to personnel.
- **BE ALERT** at all times during vehicle operation for exhaust odors and exposure symptoms. If either is present, **IMMEDIATELY VENTILATE** personnel compartments. If symptoms persist, remove affected personnel to fresh air and keep warm. **DO NOT PERMIT PHYSICAL EXERCISE**. If necessary, give artificial respiration and get immediate medical attention. For artificial respiration, refer to FM 4-25.11 . Failure to comply may result in injury or death to personnel.

- BE AWARE that the gas particulate filter unit or field protection mask for nuclear-biological-chemical protection WILL NOT offer safety from carbon monoxide poisoning.
- THE BEST DEFENSE AGAINST CARBON MONOXIDE POISONING IS GOOD VENTILATION.

WARNING



Attempting to operate heater with frozen or slushy coolant could cause coolant hose to burst or separate from heater. Make sure proper mixture of water and anti-freeze (refer to lubrication table) is maintained at all times. Failure to comply may result in damage to engine and/or injury to personnel.

WARNING



- The arctic engine heater must be off when filling any fuel tanks on vehicle. Failure to comply may result in injury or death to personnel.
- Do not operate arctic engine heater in garages or enclosed areas without proper ventilation. Failure to comply may result in injury or death to personnel.

CAUTION

- Do not attempt to operate arctic engine heater if arctic engine heater fails to start during normal startup, or shutdown occurs during normal operation. System shutdown may indicate an arctic engine heater system fault. Failure to comply may cause system lockout.
- Do not operate arctic engine heater if arctic engine heater light flashes intermittently during normal operations. Arctic engine heater indicator light flashing indicates an arctic engine heater system fault. Failure to comply may cause system lockout.

NOTE

- The arctic engine heater will attempt to start two times per start cycle. After the second failed start attempt, the arctic engine heater will not

operate until the arctic engine heater on/off switch is turned OFF and back ON.

- If arctic engine heater flame out occurs during operation, arctic engine heater will attempt one restart. If unsuccessful, arctic engine heater will shutdown.
 - During operation, arctic engine heater continually monitors input voltage. If the arctic engine heater input voltage decreases below (20 V) or increases above (30 V), arctic engine heater will automatically shutdown.
1. Set arctic engine heater switch (1) to ON position. Observe arctic engine heater indicator light (2) for steady illumination.

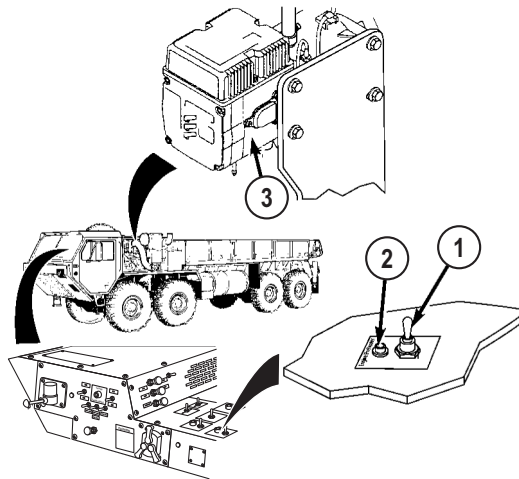

Figure 1.

2. Observe arctic engine heater (3) for proper operation.
3. Operate arctic engine heater (3) for 35 minutes to warm engine.
4. After 35 minutes, start engine. (WP 0044)
5. After engine is started, set arctic engine heater switch (1) in OFF position. Indicator light (2) will go out.

END OF TASK

END OF WORK PACKAGE

**OPERATOR MAINTENANCE
OPERATE GAS PARTICULATE FILTER UNIT (GPFU)**

INITIAL SETUP:

Not Applicable

OPERATE GPFU

WARNING

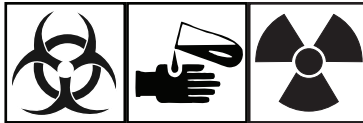

- BE AWARE that the gas particulate filter unit or the field protective mask for nuclear-biological-chemical protection WILL NOT offer safety from carbon monoxide poisoning.
- If NBC exposure is suspected, all air filter media should be handled by personnel wearing protective equipment. Consult your unit NBC Officer or NBC NCO for appropriate handling or disposal procedures.
- If required to remain inside the vehicle during extreme heat, occupants should follow the water intake, work/rest cycle, and other heat stress preventive medicine measures contained in FM 21-10, Field Hygiene and Sanitation. Failure to comply may result in injury or death to personnel.

NOTE

- Do Steps (1) through (8) only when under Nuclear, Biological, or Chemical (NBC) attack and/or when ordered to do so.
 - For detailed information concerning protective mask, refer to TM 3-4240-280-10.
 - Both crew stations have M-3 heater, hose, and air duct sockets.
1. Remove two protective masks (1) and canisters (2) from pouches (3).

OPERATE GPFU - Continued

Figure 1.

2. Put on protective masks (1).
3. Clear and seal protective masks (1).

NOTE

Spring clip must be repositioned on filter assembly air intake so intake holes are open for gas particulate filter system to work. Clip is repositioned through bottom of bracket.

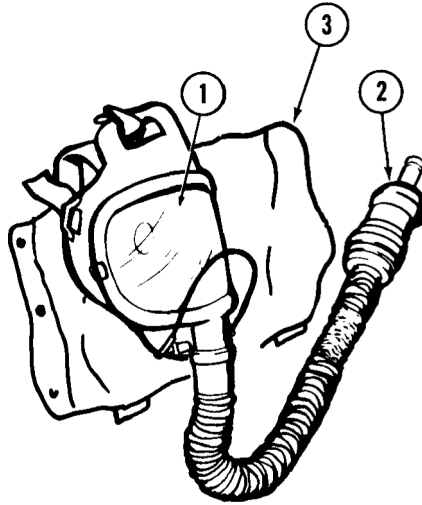
4. Pull down on spring clip (4) to uncover intake holes (5).

OPERATE GPFU - Continued

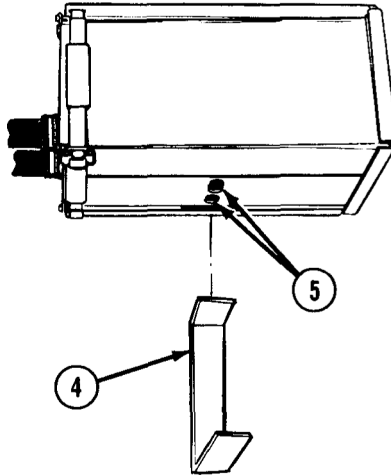
*Figure 2.*

5. Set GAS PARTICULATE FILTER switch (6) to ON.

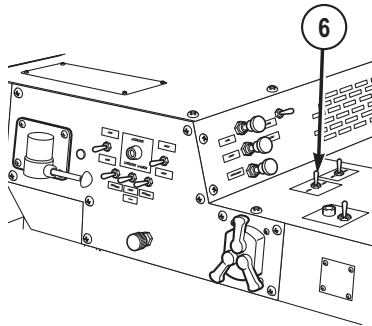
*Figure 3.*

OPERATE GPFU - Continued**NOTE**

One mount is located to left of drivers seat at roof brace. Second mount is located on middle cab roof brace to left of passenger seat.

6. Disconnect two air duct hose breakaway sockets (7) from mounts (8).

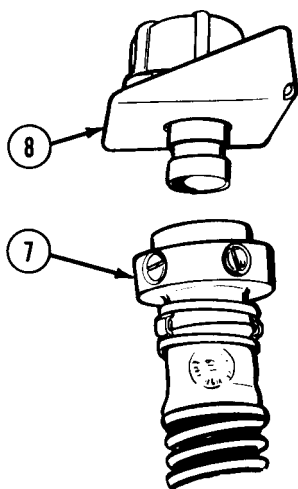

Figure 4.

WARNING

Under arctic conditions, danger of frostbite exists. Mask can be put on, but air duct hose socket shall not be connected to mask canister until M-3 heater has been on for 15 minutes. Failure to comply may result in injury or death to personnel.

7. Connect two air duct hose breakaway sockets (7) to canisters (2) of protective masks (1) and breathe through masks.

OPERATE GPFU - Continued

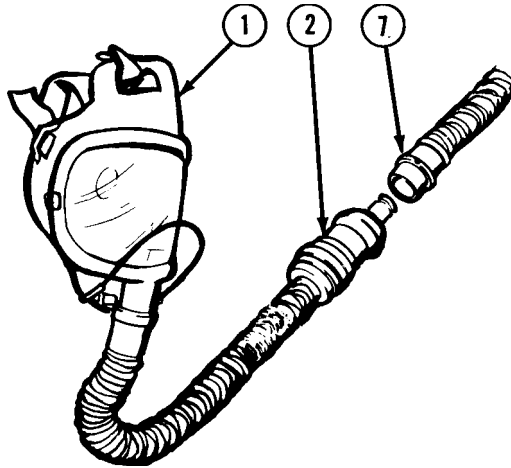

Figure 5.

NOTE

- There are two M-3 heaters. Both are the same.
 - Heater indicator light will go off and on during normal heater operation.
8. If air is too cold to breathe comfortably, turn knob (9) clockwise until heater indicator (10) lights. To adjust temperature:

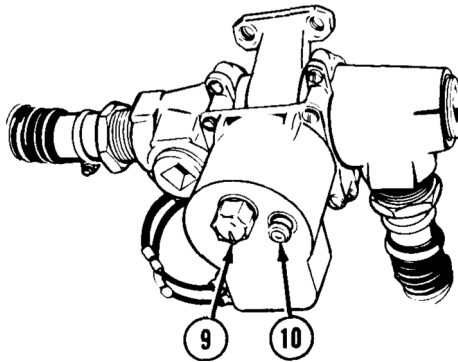

Figure 6.

- a. Turn knob (9) clockwise for warmer air.
- b. Turn knob (9) counterclockwise for cooler air.

OPERATE GPFU - Continued

9. When heater is no longer needed, turn control knob (9) counterclockwise to OFF position.

NOTE

Do Steps (1) through (5) only when Nuclear, Biological, or Chemical (NBC) attack is over and/or when ordered to do so.

1. When protective masks (1) are no longer needed, disconnect air duct hose breakaway sockets (2) from canisters (3).

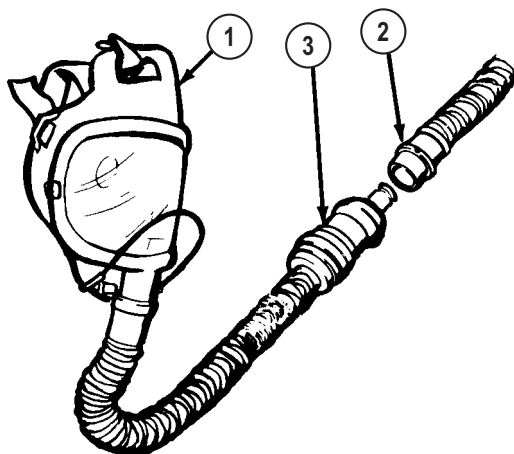

Figure 7.

2. Connect two air duct hose breakaway sockets (2) to mounts (4).

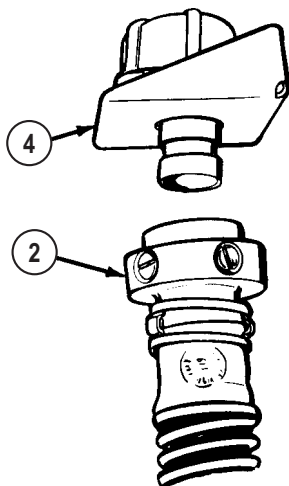

Figure 8.

3. Set GAS PARTICULATE FILTER switch (5) to OFF.

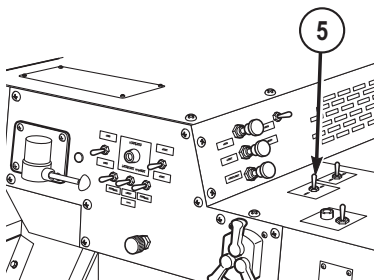

Figure 9.

4. Push up on spring clip (6) to cover intake holes (7).

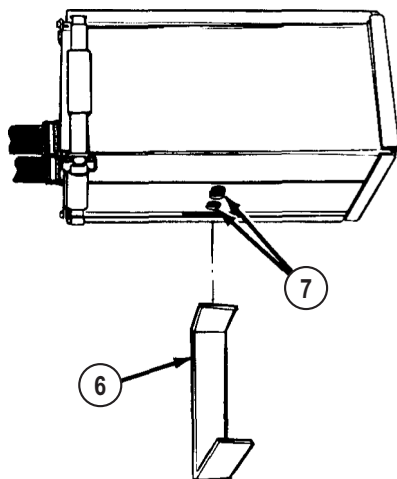

Figure 10.

5. Remove and stow two protective masks (1).

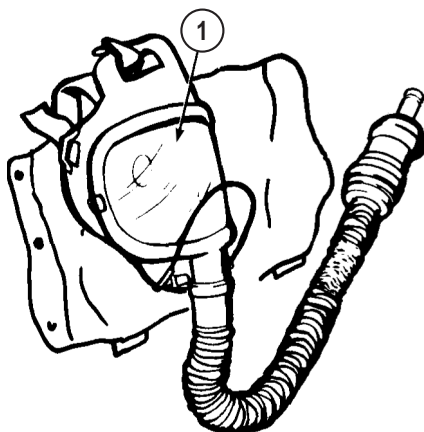

Figure 11.

END OF TASK

END OF WORK PACKAGE

**OPERATOR MAINTENANCE
OPERATE RIFLE STOWAGE MOUNT**

INITIAL SETUP:

Not Applicable

STOW RIFLE IN STOWAGE MOUNT

1. Position butt (1) of M-16 rifle (2) in lower mount (3) with trigger guard (4) toward rear of vehicle.

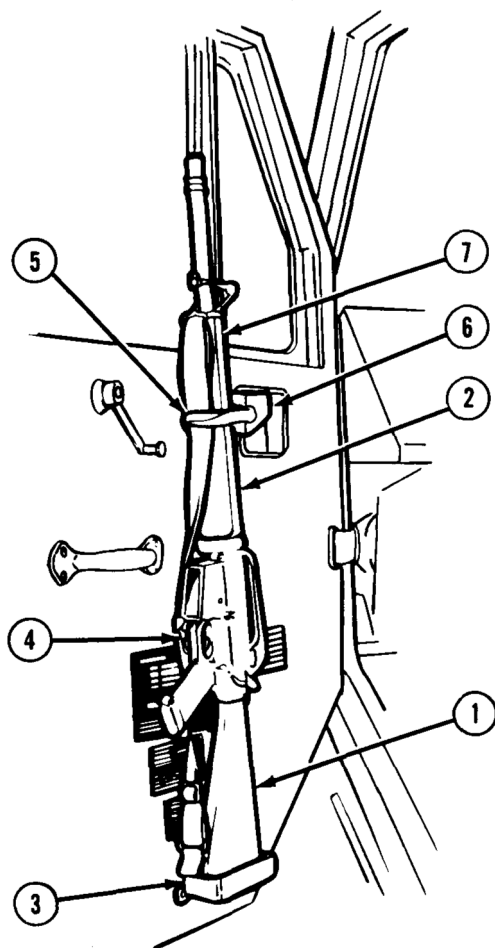
STOW RIFLE IN STOWAGE MOUNT - Continued*Figure 1.*

2. Pull handle (5) of top mount (6) toward middle of cab.
3. Place heat guard (7) of M-16 rifle (2) in top mount (6).
4. Push handle (5) across heat guard (7).
5. Check that M-16 rifle (2) is held tightly.

REMOVE RIFLE FROM STOWAGE MOUNT

1. Pull handle (1) of top mount (2) down and toward middle of cab.

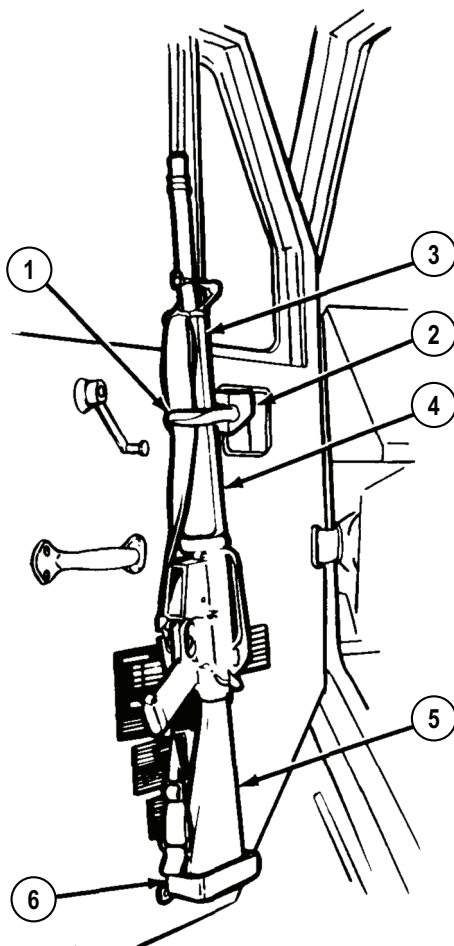
REMOVE RIFLE FROM STOWAGE MOUNT - Continued*Figure 2.*

2. Remove heat guard (3) of M-16 rifle (4) from top mount (2).
3. Remove butt (5) of M-16 rifle (4) from lower mount (6).

END OF TASK**END OF WORK PACKAGE**

**OPERATOR MAINTENANCE
OPERATE MACHINE GUN MOUNT**

INITIAL SETUP:

Not Applicable

REFERENCE

For operation of the machine gun mount, refer to TM 9-1005-245-13&P. (WP 0161)

END OF TASK

END OF WORK PACKAGE

**OPERATOR MAINTENANCE
OPERATE M-8 CHEMICAL ALARM**

INITIAL SETUP:

Not Applicable

REFERENCE

For operation of the M-8 Chemical Alarm, refer to TM 3-6665-225-12. (WP 0161)

END OF TASK

END OF WORK PACKAGE

**OPERATOR MAINTENANCE
OPERATE M-13 DECONTAMINATION KIT**

INITIAL SETUP:

Not Applicable

REFERENCE

For operation of the M-13 Decontamination Kit, refer to TM 3-4230-214-12&P. (WP 0161)

END OF TASK

END OF WORK PACKAGE

**OPERATOR MAINTENANCE
OPERATE RADIO**

INITIAL SETUP:

Not Applicable

REFERENCE

For operation of the radio, refer to TM 11-5820-498-12. (WP 0161)

END OF TASK

END OF WORK PACKAGE

**OPERATOR MAINTENANCE
PORTABLE WORK LAMP OPERATION**

INITIAL SETUP:

Not Applicable

INSTALL/OPERATE/REMOVE PORTABLE WORK LAMP**NOTE**

Ensure that 24V battery disconnect switch is ON (WP 0079) before operating work lamp.

1. Remove work lamp (1) and work lamp harness (2) from stowage.

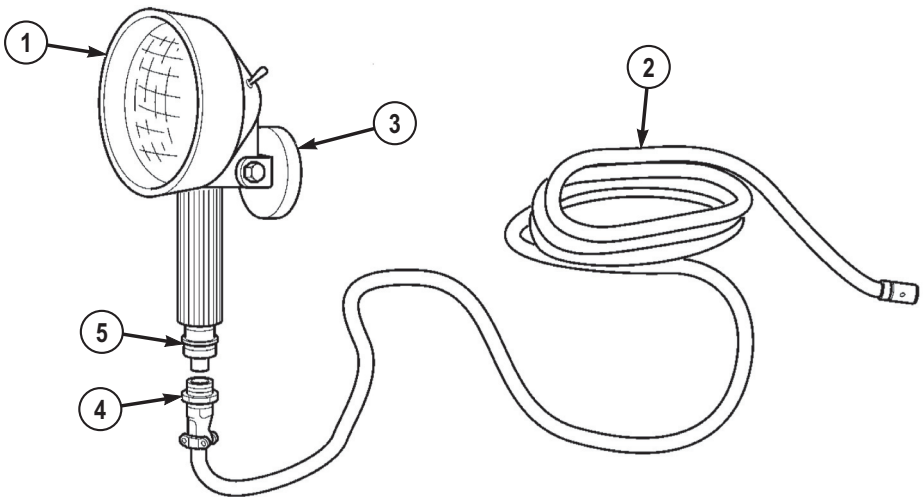
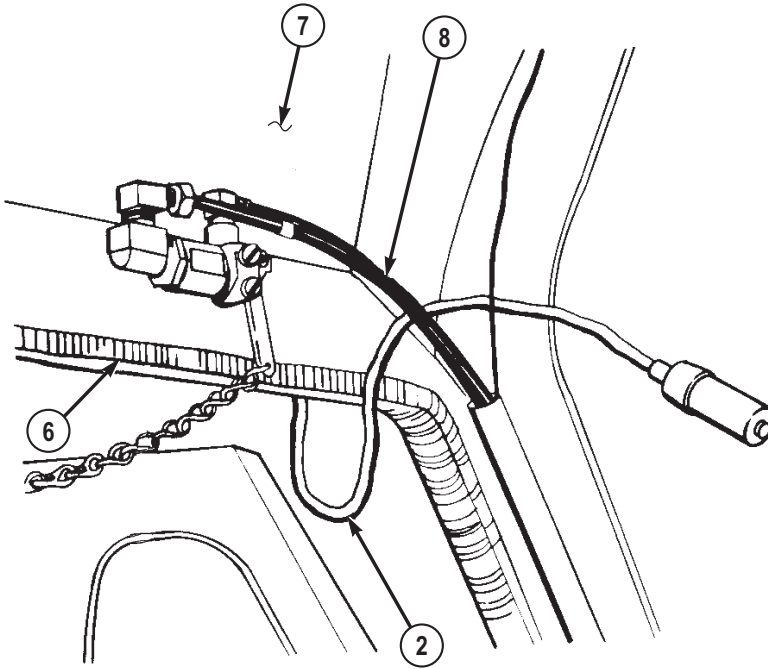

Figure 1.

2. Mount work lamp (1) on vehicle using magnet (3).
3. Install work lamp harness plug (4) on work lamp terminal (5).
4. Route work lamp harness (2) through driver side door opening (6), between inside of cab roof (7) and air horn valve hoses (8).

INSTALL/OPERATE/REMOVE PORTABLE WORK LAMP - Continued

*Figure 2.*

5. Route work lamp harness (2) across driver side defroster (9) and across center console (10) to utility outlet (11).

INSTALL/OPERATE/REMOVE PORTABLE WORK LAMP - Continued

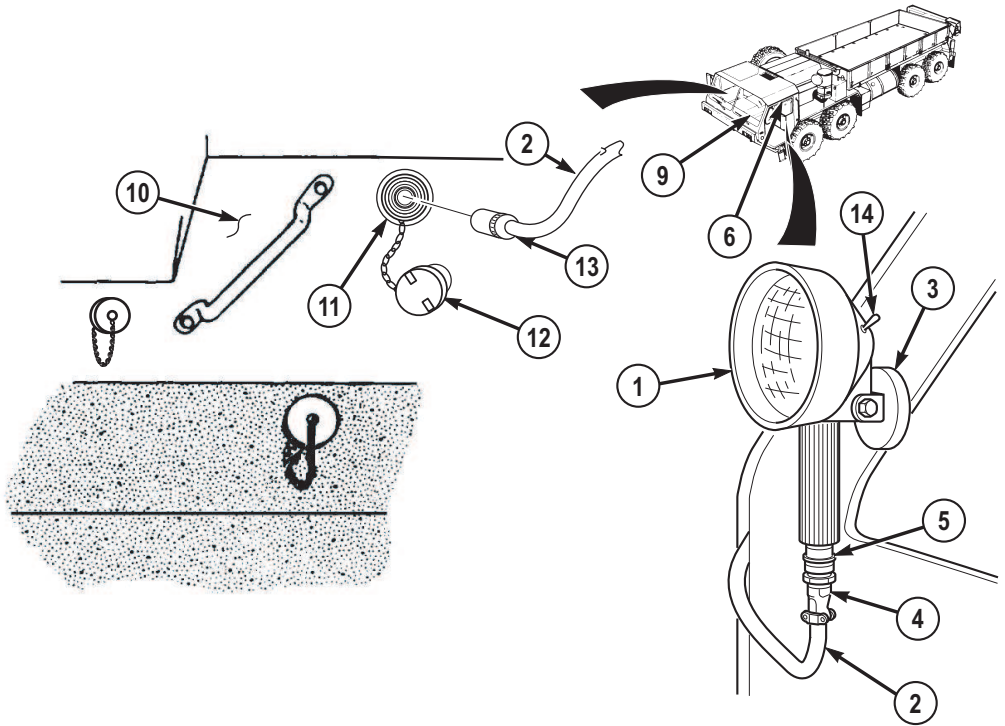

Figure 3.

6. Remove utility outlet cover (12). Insert work lamp harness plug (13) into utility outlet (11).
7. Turn on work lamp (1) using toggle switch (14).

NOTE

Perform Steps (8) through (13) when use of the portable work lamp is no longer required.

8. Turn off work lamp (1) using toggle switch (14).
9. Remove work lamp harness plug (13) from utility outlet (11). Install utility outlet cover (12).
10. Remove work lamp harness (2) from interior of cab.
11. Remove work lamp harness plug (4) from work lamp terminal (5).
12. Disengage magnet (3) from vehicle.

INSTALL/OPERATE/REMOVE PORTABLE WORK LAMP - Continued

13. Return work lamp (1) and work lamp harness (2) to proper stowage.

END OF TASK

END OF WORK PACKAGE

**OPERATOR MAINTENANCE
OPERATE DOME LIGHT**

INITIAL SETUP:

Not Applicable

TURN DOME LIGHT ON/OFF**CAUTION**

Failure to place light switches in off position when vehicle is not in use may cause battery and/or vehicle damage.

NOTE

- Dome light is located on very rear of cabin overhead centered between operator and crew seats.
 - Dome light switch is a 2-position switch; down is off, up is on.
 - Dome light is disabled whenever blackout lights are selected on the light control.
 - Ensure that the 24V battery disconnect switch is set to ON position (WP 0079) before operating lights.
1. Lift up and hold UNLOCK lever (1).

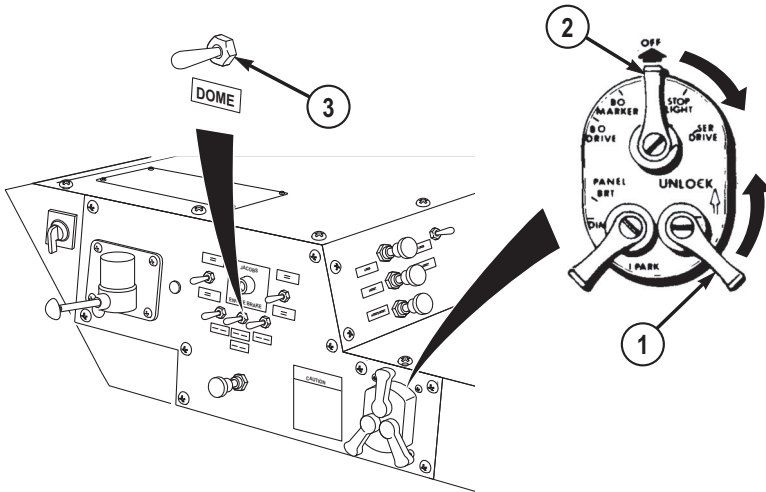
TURN DOME LIGHT ON/OFF - Continued*Figure 1.*

2. Set lighting control lever (2) to STOP LIGHT or SER DRIVE position.
3. Release UNLOCK lever (1).
4. Set DOME switch (3) to on position.

NOTE

Complete Steps (5) and (6) when dome light is no longer required.

5. Set DOME switch (3) to off position.
6. Set lighting control lever (2) to OFF position.

END OF TASK**END OF WORK PACKAGE**

**OPERATOR MAINTENANCE
OPERATE PANEL LIGHTS**

INITIAL SETUP:

Not Applicable

TURN PANEL LIGHTS ON/OFF**CAUTION**

Failure to place light switches in the off position when vehicle is not in use may cause battery and/or vehicle damage.

NOTE

Ensure that the 24V battery disconnect switch is set to ON position (WP 0079) before operating lights.

1. Lift up and hold UNLOCK lever (1).

TURN PANEL LIGHTS ON/OFF - Continued

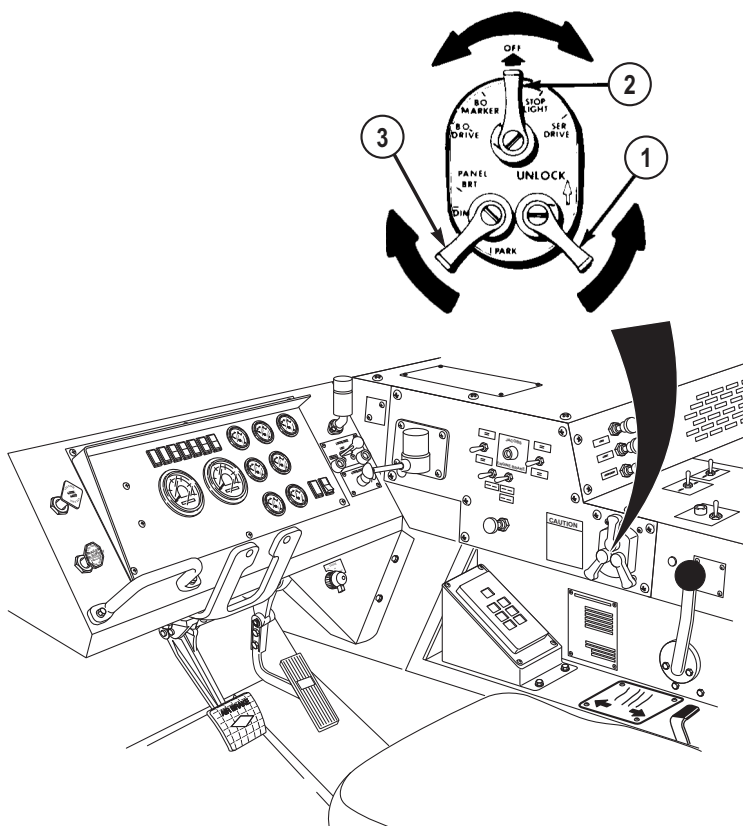

Figure 1.

NOTE

Panel lights will not function if lighting control lever is in OFF position.

2. Set lighting control lever (2) to desired position.
3. Release UNLOCK lever (1).
4. Set PANEL lever (3) to DIM or BRT (bright) as needed.

NOTE

Complete Steps (5) and (6) when panel lights are no longer required.

5. Set PANEL lever (3) to OFF position.

TURN PANEL LIGHTS ON/OFF - Continued

6. Set lighting control lever (2) to OFF position.

END OF TASK

END OF WORK PACKAGE

**OPERATOR MAINTENANCE
OPERATE PARKING LIGHTS**

INITIAL SETUP:

Not Applicable

TURN PARKING LIGHTS ON/OFF**CAUTION**

Failure to place light switches in the off position when vehicle is not in use may cause battery and/or vehicle damage.

NOTE

Ensure that the 24V battery disconnect switch is set to ON position (WP 0079) before operating lights.

1. Lift up and hold UNLOCK lever (1).

TURN PARKING LIGHTS ON/OFF - Continued

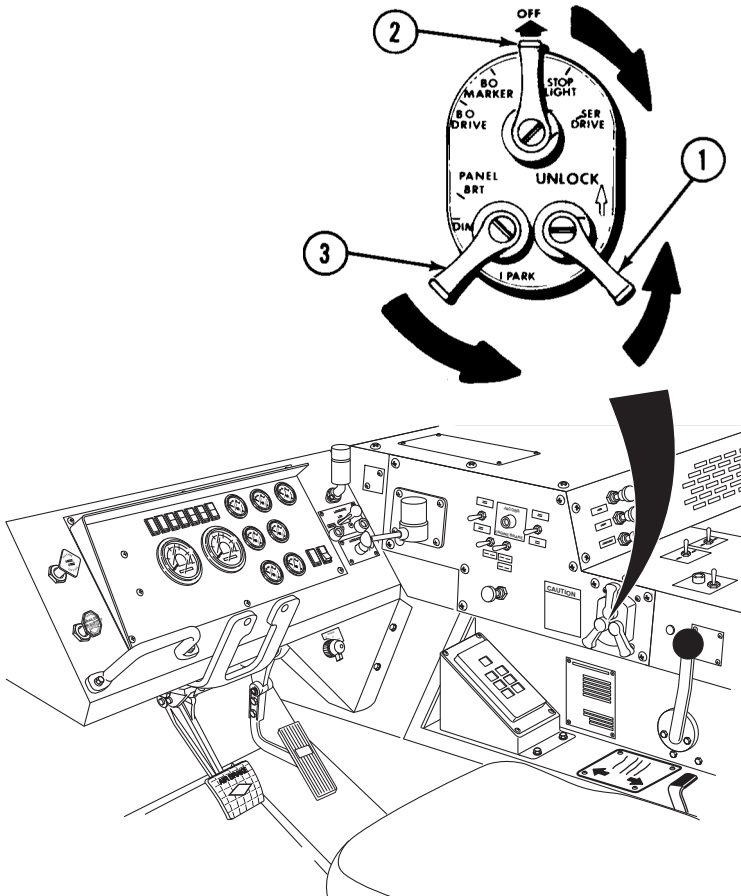

Figure 1.

2. Set lighting control lever (2) to SER DRIVE position.
3. Set PANEL lever (3) to PARK position.
4. Release UNLOCK lever (1).

NOTE

Complete Steps (5) and (6) when parking lights are no longer required.

5. Set PANEL lever (3) to OFF position.

TURN PARKING LIGHTS ON/OFF - Continued

6. Set lighting control lever (2) to OFF position.

END OF TASK

END OF WORK PACKAGE

OPERATOR MAINTENANCE OPERATE SERVICE DRIVE LIGHTS

INITIAL SETUP:

Not Applicable

TURN SERVICE DRIVE LIGHTS ON/OFF

CAUTION

Failure to place light switches in the off position when vehicle is not in use may cause battery and/or vehicle damage.

NOTE

Ensure that the 24V battery disconnect switch is set to ON position (WP 0079) before operating lights.

1. Lift up and hold UNLOCK lever (1).

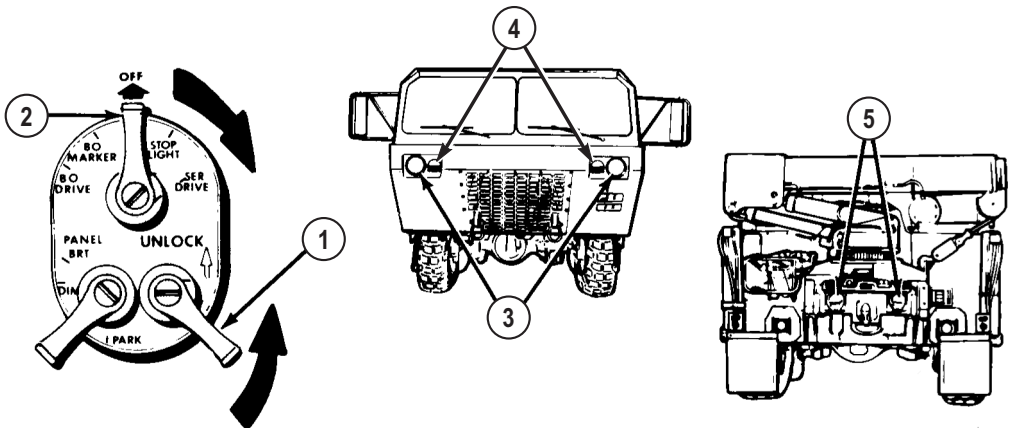

Figure 1.

2. Set lighting control lever (2) to SER DRIVE position.

TURN SERVICE DRIVE LIGHTS ON/OFF - Continued**NOTE**

Service stop lights (incorporated in taillights) will illuminate when service brake pedal is applied.

3. Release UNLOCK lever (1). Service headlights (3), composite lights (4), and taillights (5) will illuminate.
4. Press dimmer switch (6) with foot to cycle between high and low headlight beams. High beam indicator (7) will illuminate (blue) when high beams are selected.

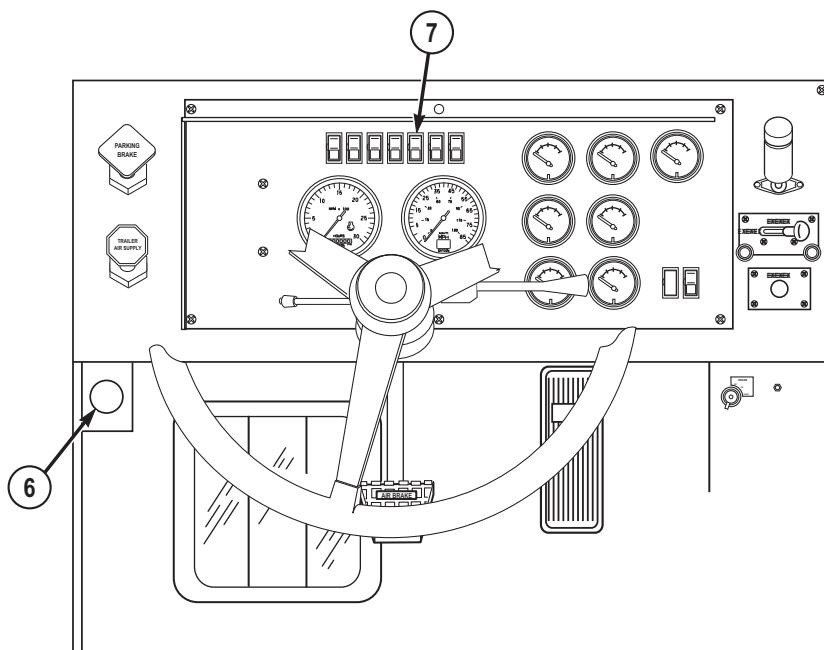

Figure 2.

NOTE

Complete Step (5) when service drive lights are no longer required.

5. Set lighting control lever (2) to OFF position. Service headlights (3), composite lights (4), and taillights (5) will go out.

TURN SERVICE DRIVE LIGHTS ON/OFF - Continued

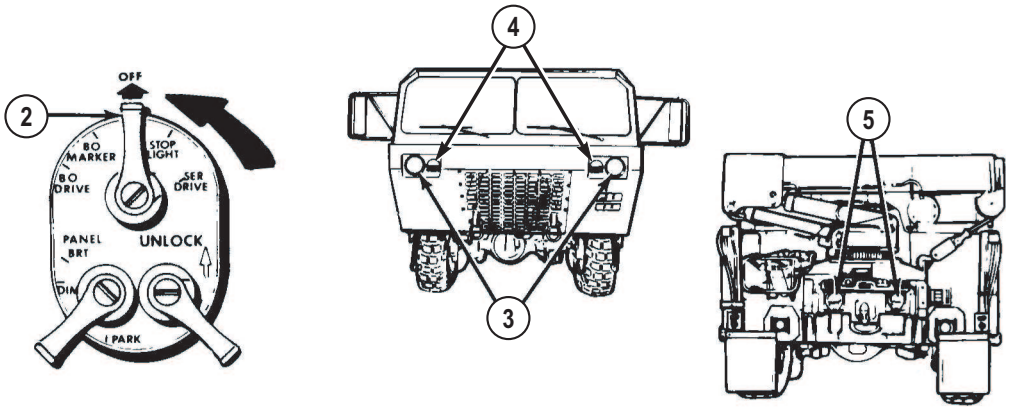

Figure 3.

END OF TASK

END OF WORK PACKAGE

**OPERATOR MAINTENANCE
OPERATE STOPLIGHTS**

INITIAL SETUP:

Not Applicable

TURN STOPLIGHTS ON/OFF**CAUTION**

Failure to place light switches in the OFF position when vehicle is not in use may cause battery and/or vehicle damage.

NOTE

- Ensure that the 24V battery disconnect switch is set to ON position (WP 0079) before operating lights.
 - Ensure service stoplights are turned on prior to driving vehicle.
1. Lift up and hold UNLOCK lever (1).

TURN STOPLIGHTS ON/OFF - Continued

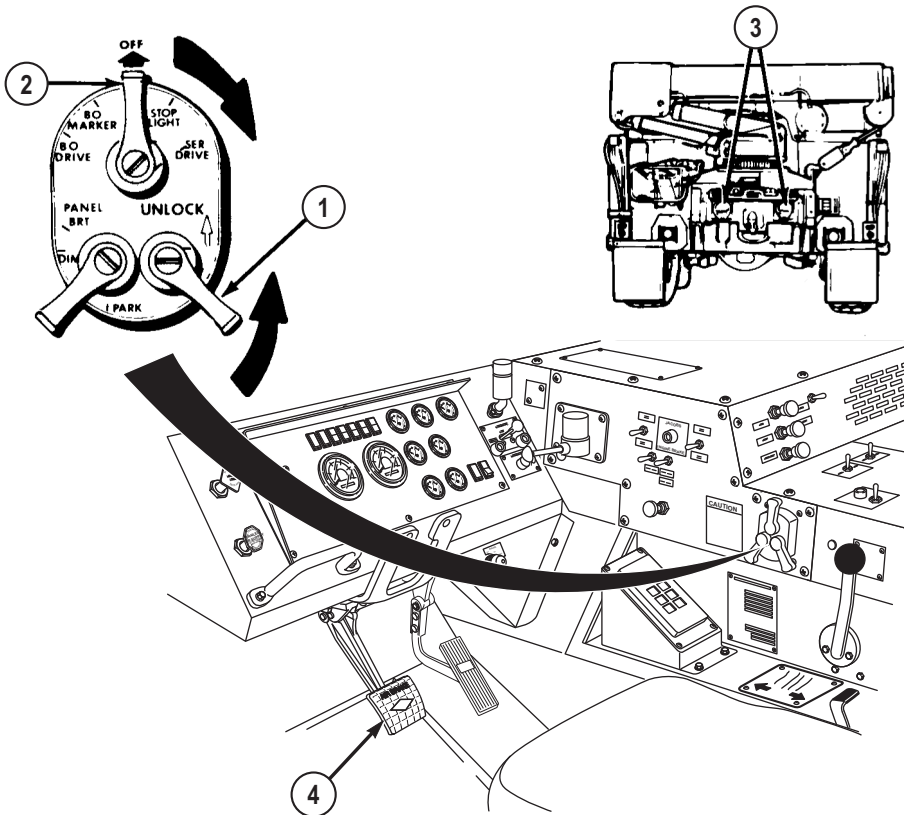

Figure 1.

2. Set lighting control lever (2) to STOP LIGHT position.
3. Release UNLOCK lever (1). Stoplights (3) will illuminate when service brake pedal is applied.

NOTE

Complete Step (4) when stoplights are no longer required.

4. Set lighting control lever (2) to OFF position. Stoplights will no longer function.

END OF TASK

END OF WORK PACKAGE

OPERATOR MAINTENANCE OPERATE CLEARANCE LIGHTS

INITIAL SETUP:

Not Applicable

TURN CLEARANCE LIGHTS ON/OFF

CAUTION

Failure to place light switches in the OFF position when vehicle is not in use may cause battery and/or vehicle damage.

NOTE

Ensure that the 24V battery disconnect switch is set to ON position (WP 0079) before operating lights.

1. Lift up and hold UNLOCK lever (1).

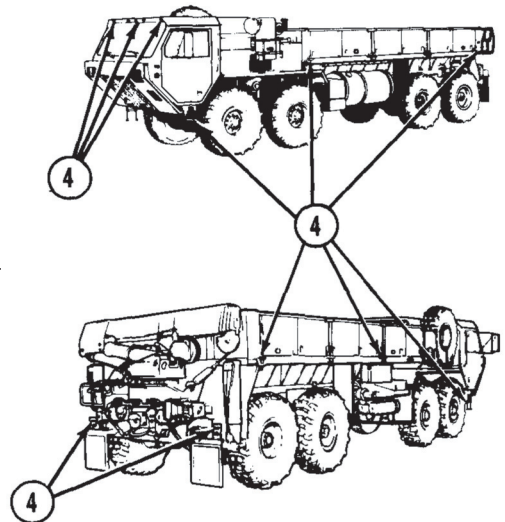
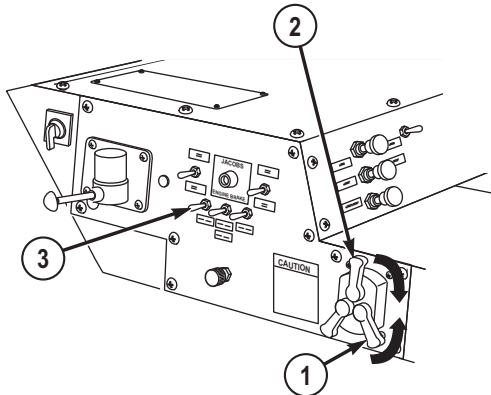

Figure 1.

2. Set lighting control lever (2) to either STOP LIGHT or SER DRIVE position.

TURN CLEARANCE LIGHTS ON/OFF - Continued

3. Release UNLOCK lever (1).
4. Set CL LPS switch (3) to on position. Clearance lights (4) will illuminate.

NOTE

Complete Steps (5) and (6) when clearance lights are no longer required.

5. Set CL LPS switch (3) to off position. Clearance lights (4) will go out.
6. Set lighting control lever (2) to OFF position.

END OF TASK**END OF WORK PACKAGE**

**OPERATOR MAINTENANCE
OPERATE BLACKOUT DRIVE LIGHT**

INITIAL SETUP:

Not Applicable

TURN BLACKOUT DRIVE LIGHT ON/OFF

CAUTION

Failure to place light switches in the OFF position when vehicle is not in use may cause battery and/or vehicle damage.

NOTE

- Ensure that the 24V battery disconnect switch is set to ON position (WP 0079) before operating lights.
- Use blackout drive light for night driving under blackout conditions.
- Cabin dome light/switch, vehicle mounted work lights/switch (M983A2, M983A2 LET, M984A2, M1977A2), rear beacon lights/switch (M984A2 only), electric horn (on steering column), and reverse alarm are disabled when lighting control lever is positioned to either blackout lighting position.

1. Lift up and hold UNLOCK lever (1).

TURN BLACKOUT DRIVE LIGHT ON/OFF - Continued

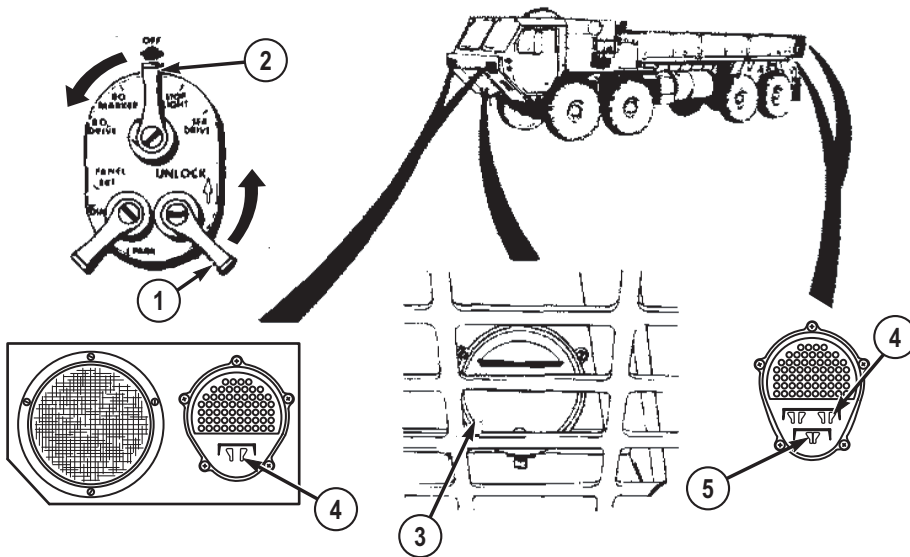

Figure 1.

2. Set lighting control lever (2) to B.O. DRIVE position.
3. Release UNLOCK lever (1); blackout drive light (3) and blackout markers (4) will illuminate.
4. Blackout stoplights (5) will illuminate when service brake pedal is applied.

NOTE

Complete Step (5) when blackout lights are no longer required.

5. Set lighting control lever (2) to OFF position; blackout drive light (3) and blackout markers (4) will go out.

END OF TASK

END OF WORK PACKAGE

**OPERATOR MAINTENANCE
OPERATE BLACKOUT MARKERS**

INITIAL SETUP:

Not Applicable

TURN BLACKOUT MARKERS ON/OFF

CAUTION

Failure to place light switches in the OFF position when vehicle is not in use may cause battery and/or vehicle damage.

NOTE

- Ensure that the 24V battery disconnect switch is set to ON position (WP 0079) before operating lights.
 - Cabin dome light/switch, vehicle mounted work lights/switch (M983A2, M983A2 LET, M984A2, M1977A2), rear beacon lights/switch (M984A2 only), electric horn (on steering column), and reverse alarm are disabled when lighting control lever is positioned to either blackout lighting position.
1. Lift up and hold UNLOCK lever (1).

TURN BLACKOUT MARKERS ON/OFF - Continued

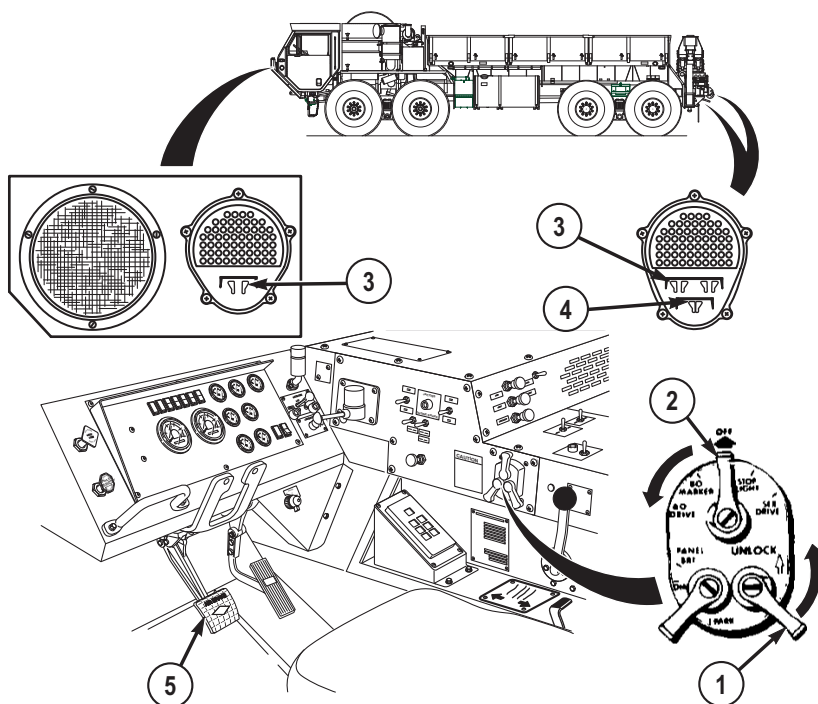

Figure 1.

2. Set lighting control lever (2) to B.O. MARKER position. Blackout markers (3) will illuminate.
3. Blackout stoplight markers (4), which are located on vehicle taillights, will illuminate when service brake pedal (5) is applied.

NOTE

Complete Step (4) when blackout markers are no longer required.

4. Set lighting control lever (2) to OFF position. Blackout markers (3) will go out.

END OF TASK**END OF WORK PACKAGE**

OPERATOR MAINTENANCE PORTABLE BEACON LIGHT OPERATION

INITIAL SETUP:

Not Applicable

INSTALL/REMOVE PORTABLE BEACON LIGHT

NOTE

Ensure that the 24V battery disconnect switch is set to ON position (WP 0079) before operating lights.

1. Remove beacon light (1) from stowage and unwind cord (2).

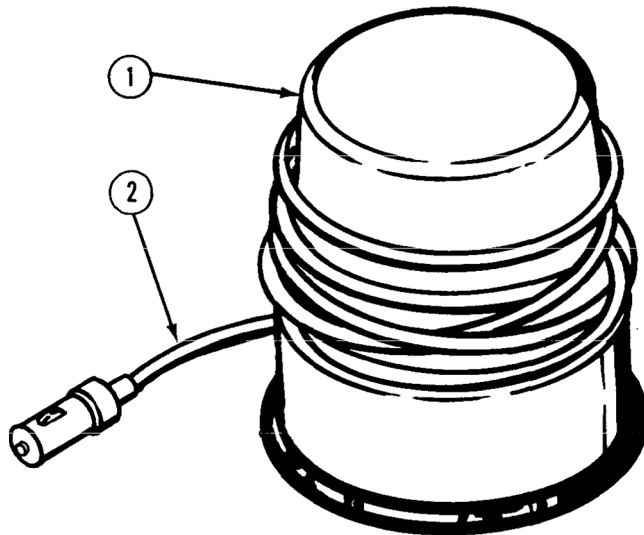
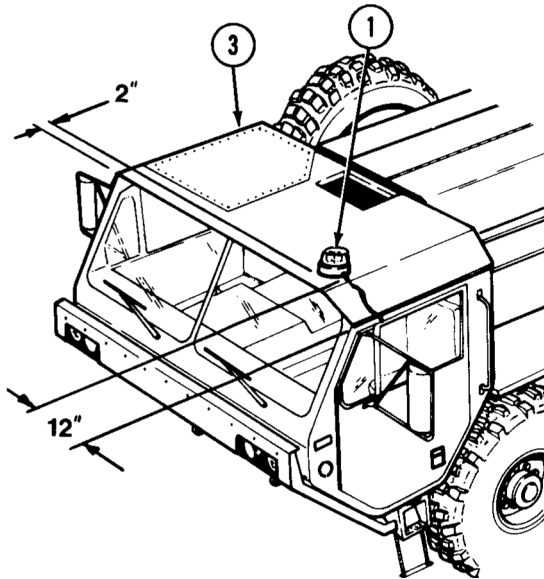

Figure 1.

2. Place beacon light (1) on driver side front corner of cab roof (3) approximately 12 in. (30 cm) from driver side cab, and approximately 2 in. (5 cm) from front edge of cab roof.

INSTALL/REMOVE PORTABLE BEACON LIGHT - Continued

*Figure 2.*

3. Route beacon cord (2) through driver side door opening (4) and between inside of cab roof (3) and air horn valve hoses (5).

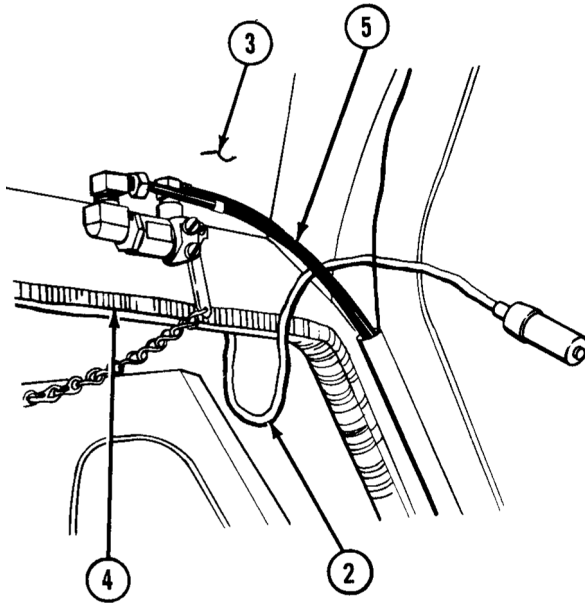
INSTALL/REMOVE PORTABLE BEACON LIGHT - Continued*Figure 3.*

4. Route beacon cord (2) down left side of driver's windshield (6), across driver side defroster (7), and across center console (8) to utility outlet (9).

INSTALL/REMOVE PORTABLE BEACON LIGHT - Continued

Figure 4.

5. Remove utility outlet cover (10).

NOTE

ENGINE switch must be positioned to ON for portable beacon light to operate.

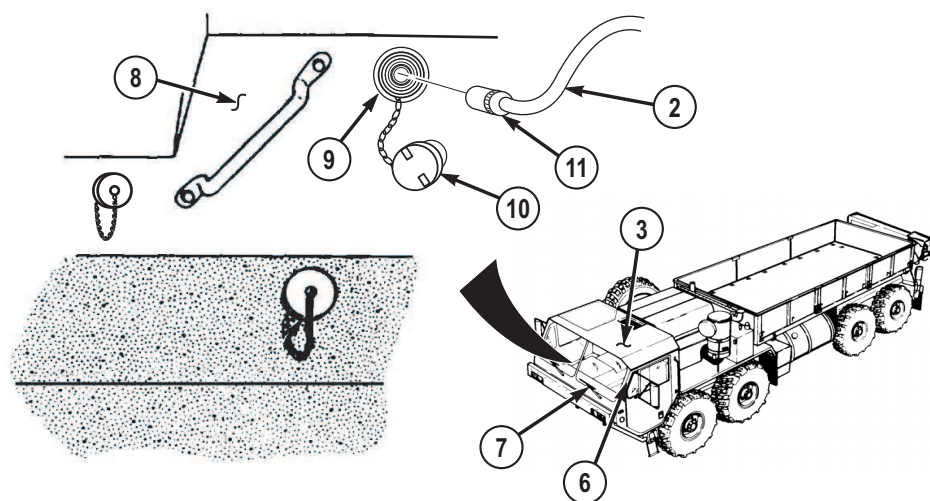
6. Insert beacon cord plug (11) into utility outlet (9).

NOTE

Perform Steps (7) through (11) when use of portable beacon light is no longer required.

7. Remove beacon cord plug (11) from utility outlet (9).
8. Install utility outlet cover (10).
9. Remove beacon cord (2) from interior of cab.
10. Remove beacon light from cab roof (3).
11. Rewind cord (2) and return beacon light (1) to appropriate stowage.

INSTALL/REMOVE PORTABLE BEACON LIGHT - Continued

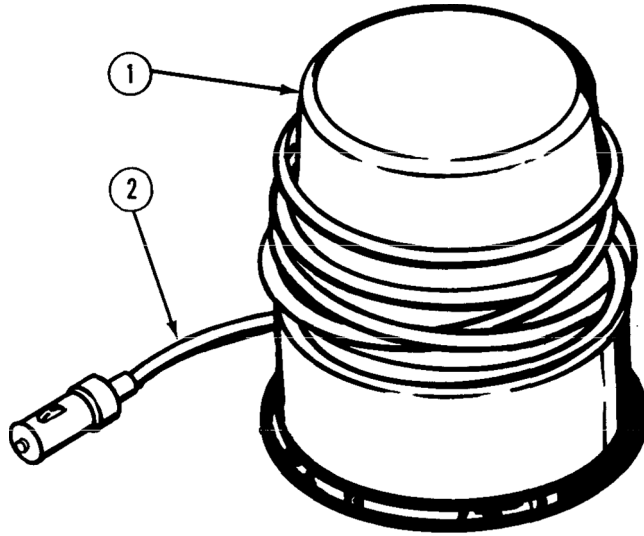

Figure 5.

END OF TASK

END OF WORK PACKAGE

**OPERATOR MAINTENANCE
OPERATE TURN SIGNALS**

INITIAL SETUP:

Not Applicable

SET TURN SIGNAL ON/OFF**NOTE**

Ensure that the 24V battery disconnect switch is set to ON position (WP 0079) before operating turn signals.

1. Lift up and hold UNLOCK lever (1).

SET TURN SIGNAL ON/OFF - Continued

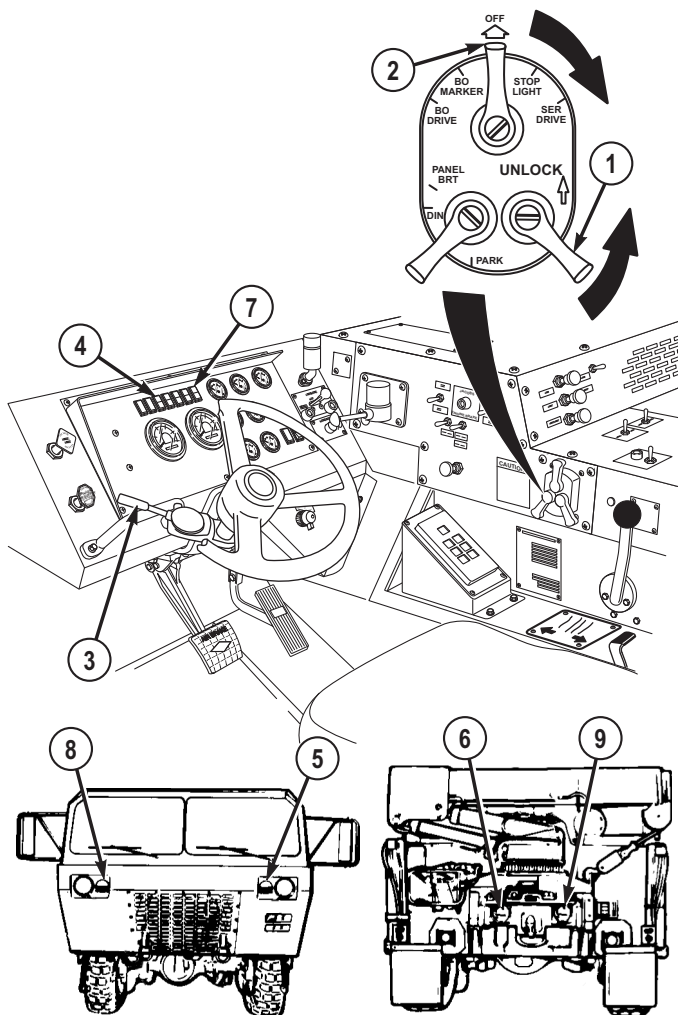

Figure 1.

2. Set lighting control lever (2) to SER DRIVE position.

NOTE

If left turn is desired, complete Step (3). If right turn is desired, skip to Step (4).

SET TURN SIGNAL ON/OFF - Continued

3. Set turn signal lever (3) down to left turn position. Left turn indicator (4), and driver side front (5) and rear (6) composite lights will flash (approximately once per second) simultaneously.

NOTE

If right turn is desired, complete Step (4).

4. Set turn signal lever (3) up to right turn position. Right turn indicator (7), and passenger side front (8) and rear (9) composite lights will flash (approximately once per second) simultaneously.

NOTE

Turn signal level may return to off (center) position automatically once turn is complete, if this is not the case and/or turn signal is no longer desired, complete Step (5).

5. Set turn signal lever (3) to center (off) position. Appropriate turn indicator and composite lights will go out.

END OF TASK**END OF WORK PACKAGE**

**OPERATOR MAINTENANCE
OPERATE EMERGENCY FLASHERS**

INITIAL SETUP:

Not Applicable

TURN EMERGENCY FLASHERS ON/OFF**NOTE**

- Ensure that the 24V battery disconnect switch is set to ON position (WP 0079) before operating emergency flashers.
- Highway Emergency Marker Kit (WP 0100) should be used to mark location and caution oncoming traffic whenever vehicle is disabled or must park in areas where there is other traffic.

1. Lift up and hold UNLOCK lever (1).

TURN EMERGENCY FLASHERS ON/OFF - Continued

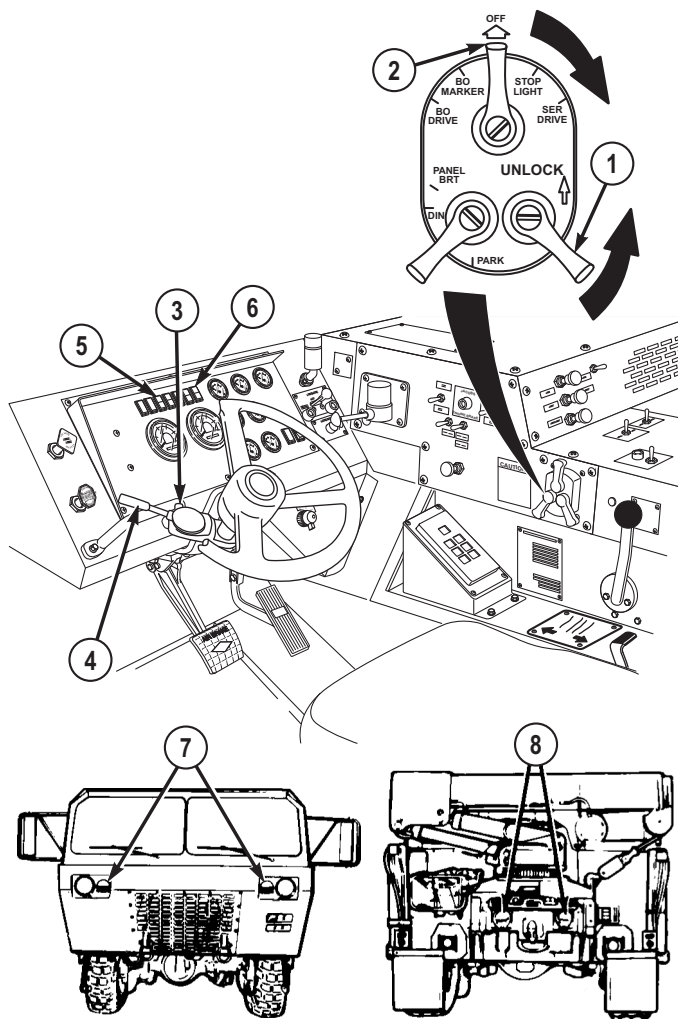

Figure 1.

2. Set lighting control lever (2) to SER DRIVE position.
3. Set turn signal lever (1) to right turn position.
4. Push down emergency flasher control (4) and push turn signal lever (3) up as far as it will go. Both left (5) and right (6) turn indicators, and front (7) and rear (8) composite lights will flash simultaneously at approximately once per second.

TURN EMERGENCY FLASHERS ON/OFF - Continued

NOTE

Perform Step (5) when emergency flashers are no longer desired.

5. Pull turn signal lever (1) down to center position.

END OF TASK

END OF WORK PACKAGE

OPERATOR MAINTENANCE INSTALL/REMOVE WHEEL CHOCKS

INITIAL SETUP:

Not Applicable

INSTALL WHEEL CHOCKS

NOTE

- Vehicle is equipped with four wheel chocks.
- Always chock tires if vehicle is shut down on uneven terrain.
- Always chock tires if vehicle parking brake is inoperative.
- Ensure local policy for chocking vehicle tires is followed.

1. Remove two wheel chocks (1) from stowage.

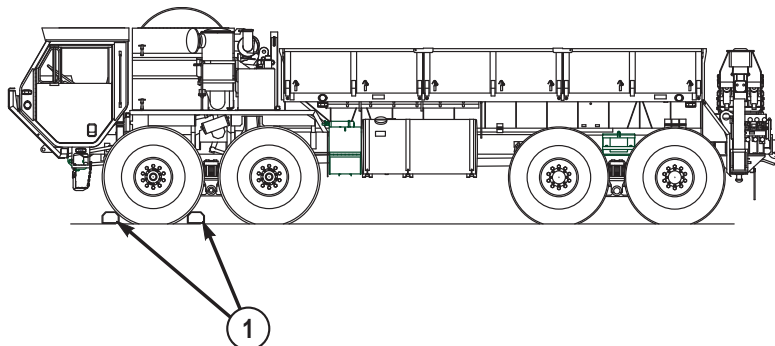

Figure 1.

2. Place one wheel chock (1) snugly against both front and rear of tire (No. 1 axle driver side tire shown).

REMOVE WHEEL CHOCKS

NOTE

- Vehicle is equipped with four wheel chocks.
- Ensure local policy for removing wheel chocks is followed.

REMOVE WHEEL CHOCKS - Continued

1. Remove wheel chocks (1) from both front and rear of tire (No. 1 axle driver side tire shown).

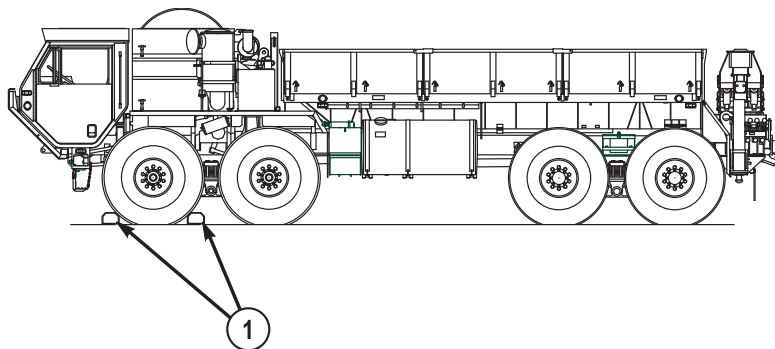

Figure 2.

2. Return wheel chocks (1) to stowage.
3. Repeat Steps (1) and (2) if more than one wheel is chocked.

END OF TASK

END OF WORK PACKAGE

OPERATOR MAINTENANCE CHANGE VEHICLE WEIGHT INDICATOR

INITIAL SETUP:

Not Applicable

CHANGE VEHICLE WEIGHT INDICATOR

NOTE

Refer to load classification table for appropriate vehicle weight.

1. Press in bottom of lockplate (1).

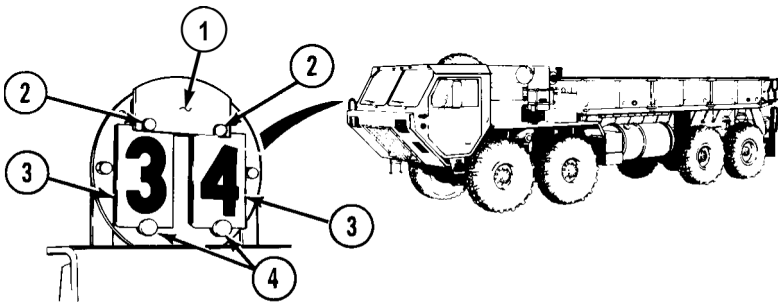

Figure 1.

2. Push lockplate (1) up and off one lockpin (2).
3. Remove number plates (3).
4. Place new number on top of number plates (3).
5. Install number plates (3) on lockpin (4).
6. Push down number plates (3). Slide lockplate (1) on lockpin (2).
7. Repeat Steps (1) through (7) to change other number.

END OF TASK

END OF WORK PACKAGE

OPERATOR MAINTENANCE
OPERATE 24V BATTERY DISCONNECT SWITCH

INITIAL SETUP:

Not Applicable

OPERATE 24V BATTERY DISCONNECT SWITCH

NOTE

All electrical power to the cab is turned ON/OFF by the 24V disconnect switch.

Turn switch (1) full clockwise (CW) to ON position, or full counterclockwise (CCW) to OFF position as desired.

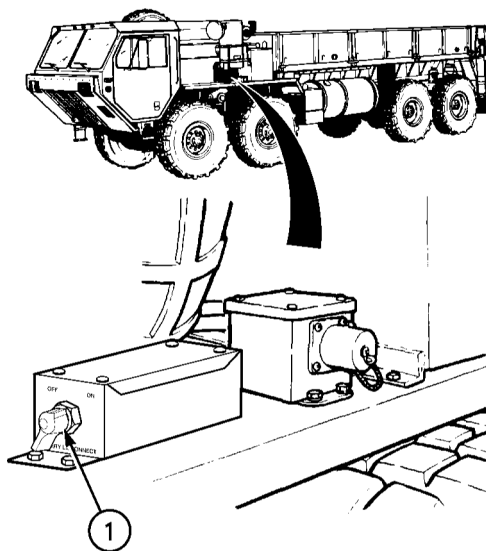

Figure 1.

END OF TASK

END OF WORK PACKAGE

**OPERATOR MAINTENANCE
ADJUST AIR-RIDE SEAT**

INITIAL SETUP:

Not Applicable

ADJUST AIR-RIDE SEAT**WARNING**

When adjusting seat ride firmness, keep fingers out from under seat. Failure to comply may result in injury or death to personnel.

NOTE

- Sit in seat and perform Steps (1) through (6) as necessary.
 - Driver and crew (passenger side) side seats are adjusted the same way.
1. Pull out (increase) or push in (decrease) knob (1) to adjust seat ride firmness.

ADJUST AIR-RIDE SEAT - Continued

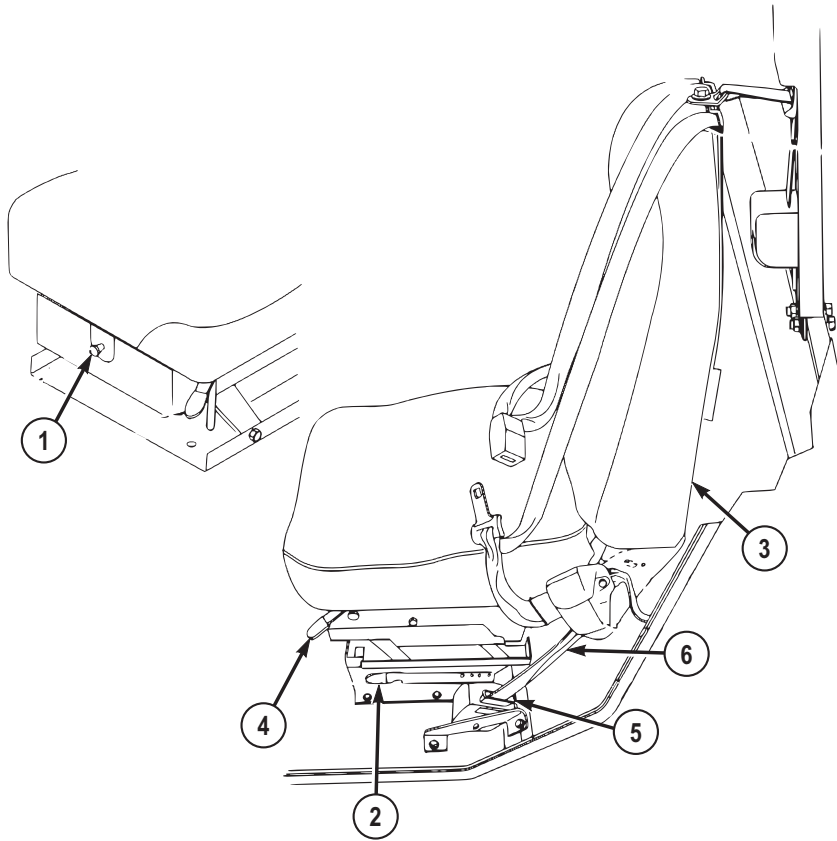

Figure 1.

2. Move lever (2) away from seat (3) and slide seat (3) forward or backwards.
3. Move lever (2) towards seat (3) to lock seat (3) in place.
4. Pull up lever (4) and lift self off seat (3) to raise, or pull up lever (4) and push down on seat (3) to lower.
5. Release lever (4) to lock seat (3) in place.
6. Adjust all vehicle mirrors as necessary once driver's seat is properly adjusted.

NOTE

If vehicle is bounced too hard, seat tether may lock seat in down position. Park vehicle (WP 0056) and perform Steps (7) through (10) to free seat.

7. Push in knob (1) to decrease seat ride firmness.

ADJUST AIR-RIDE SEAT - Continued

8. Move lever (2) away from seat (3), and slide seat (3) backwards to relieve tension on retractor (5).
9. Feed some seat tether (6) into retractor (5) until it releases.
10. Perform Steps (1) through (5) as required to reset seat (3) to desired position.

END OF TASK**END OF WORK PACKAGE**

OPERATOR MAINTENANCE OPERATE FOUR-POINT SEATBELT

INITIAL SETUP:

Not Applicable

OPERATE FOUR-POINT SEATBELT

1. Insert seatbelt flat metal end (1) into buckle (2) until click is heard.

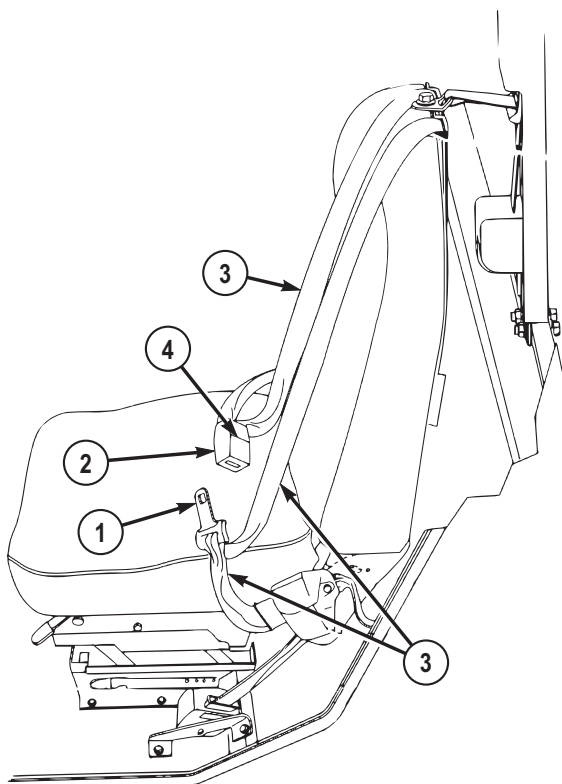

Figure 1.

OPERATE FOUR-POINT SEATBELT - Continued

2. To release seatbelt (3), push in button (4) on buckle (2).

END OF TASK

END OF WORK PACKAGE

**OPERATOR MAINTENANCE
LIMP HOME/FLAT TIRE WITH NO SPARE**

INITIAL SETUP:

Not Applicable

INSTALL LIMP HOME SETUP ON PASSENGER SIDE FRONT OR ANY REAR WHEEL

CAUTION

- Do not use this procedure on fully loaded M983 vehicle with trailer in tow. Limp home setup will not support extra weight and equipment could be damaged.
- Vehicle must not be driven faster than 10 mph (16 km/h) or farther than 30 miles (48 km) in limp home condition.

NOTE

- Use limp home procedure for emergency only in case of wheel bearing failure, wheel damage, or when unable to change wheel and tire.
 - For limp home setup on driver side front No. 1 and 2 axles, refer to Limp Home Setup/Driver Side Front section.
 - Limp home setup for No. 4 axle is shown. Other limp home setups are done in same manner.
1. Remove two wheel chocks (1), jack base plate (2), jack (3), 7 ft. (2.1 m) chain (4), and shackle (5) from stowage.

INSTALL LIMP HOME SETUP ON PASSENGER SIDE FRONT OR ANY REAR WHEEL - Continued

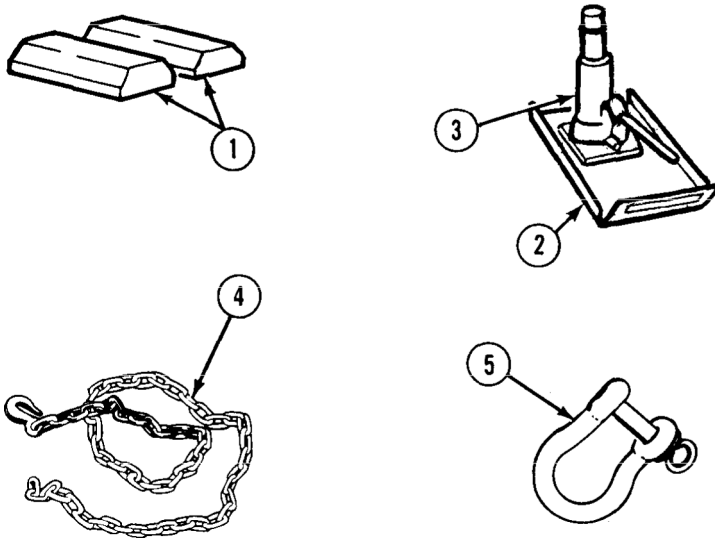

Figure 1.

2. Install two wheel chocks (WP 0077) (1) in front of and behind tire (6) across from tire (7) being raised.

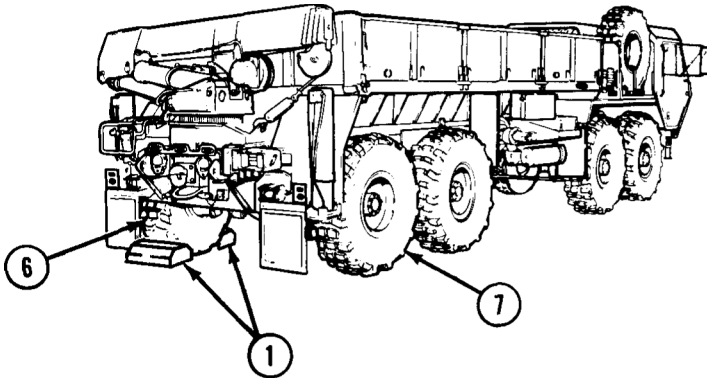

Figure 2.

3. Position jack base plate (2) and jack (3) under equalizer beam (8) 4 to 5 in. (102 to 127 mm) from center pivot point (9) towards axle to be raised (No. 4 axle shown).

INSTALL LIMP HOME SETUP ON PASSENGER SIDE FRONT OR ANY REAR WHEEL - Continued

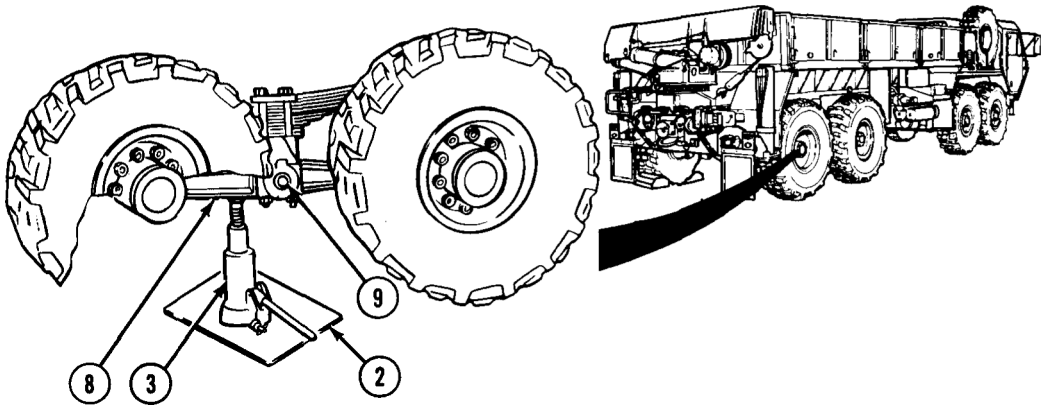

Figure 3.

4. Raise jack (3) until it touches equalizer beam (8).
5. Raise jack (3) until axle (10) is as close as it will go to axle stop (11).

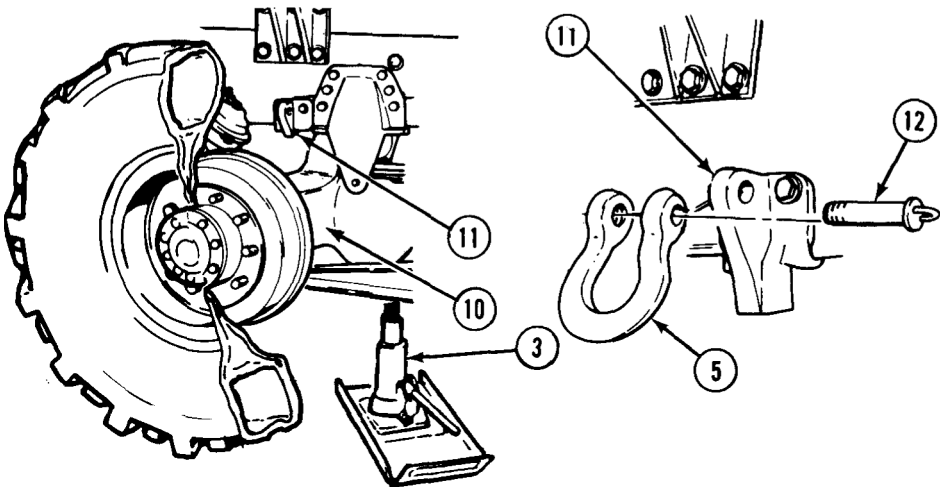

Figure 4.

6. Install shackle (5) on axle stop (11) with pin (12).

INSTALL LIMP HOME SETUP ON PASSENGER SIDE FRONT OR ANY REAR WHEEL - Continued**CAUTION**

Do not wrap 7 ft. (2.1 m) chain around any air line or brake chamber bracket. Air line could be crushed and damaged to bracket could result.

7. Route 7 ft. (2.1 m) chain (4) through shackle (5).

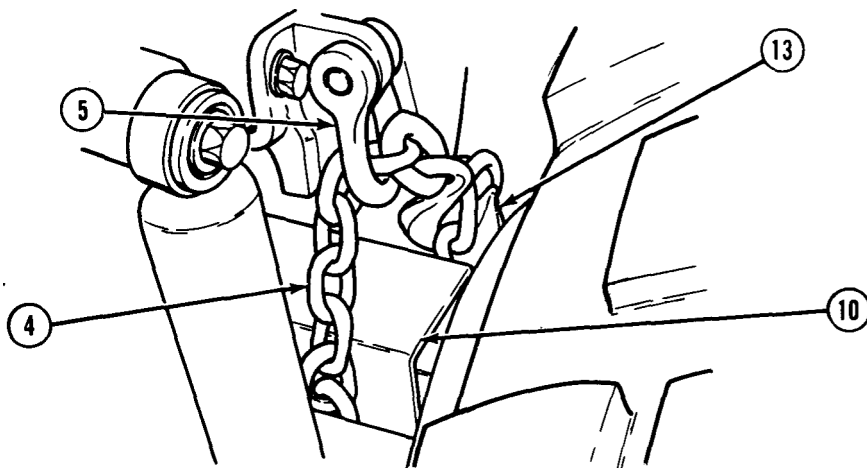

Figure 5.

8. Loop end of 7 ft. (2.1 m) chain (4) around axle (10).
9. Bring 7 ft. (2.1 m) chain (4) up to chain hook (13) and fasten as tight as possible.

WARNING

Keep hands away from chain when lowering jack. Hands and fingers could be crushed. Failure to comply may result in injury or death to personnel.

NOTE

Axle will drop slightly when jack is lowered.

10. Lower jack (3) and remove jack from under equalizer beam (8).

INSTALL LIMP HOME SETUP ON PASSENGER SIDE FRONT OR ANY REAR WHEEL - Continued

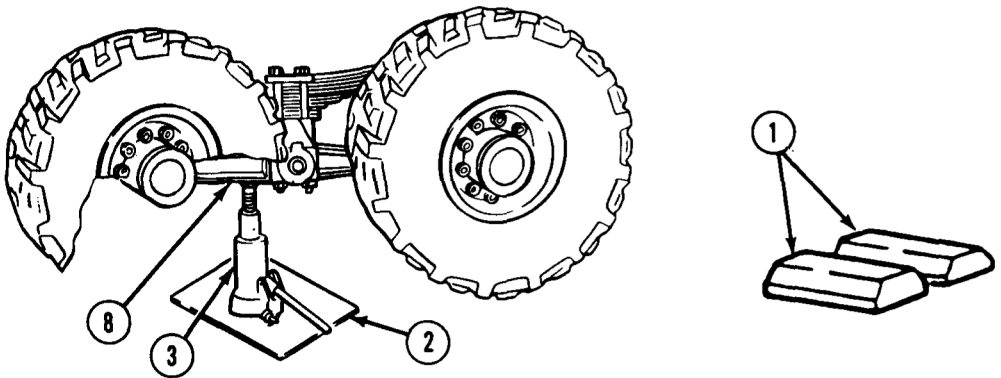

Figure 6.

11. Return jack (3), and jack base plate (2) to stowage.
12. Remove and stow two wheel chocks (1).

REMOVE LIMP HOME SETUP FROM PASSENGER SIDE FRONT OR ANY REAR WHEEL

1. Remove two wheel chocks (1), jack base plate (2), and jack (3) from stowage.

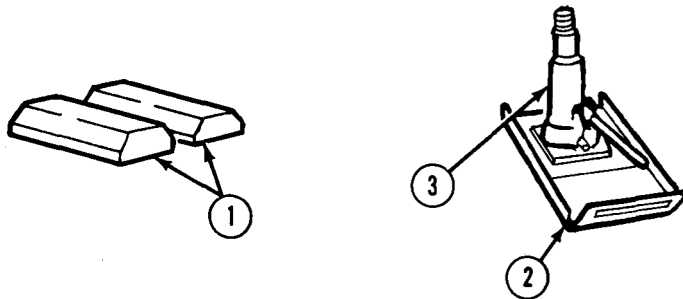

Figure 7.

2. Install two wheel chocks (WP 0077) (1) in front of and behind tire (4) across from tire (5) being raised.

REMOVE LIMP HOME SETUP FROM PASSENGER SIDE FRONT OR ANY REAR WHEEL - Continued

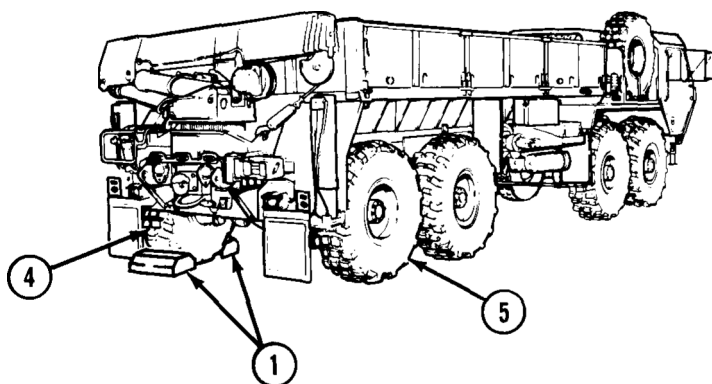

Figure 8.

3. Position jack base plate (2) and jack (3) under equalizer beam (6) 4 to 5 in. (102 to 127 mm) from center pivot point (7).

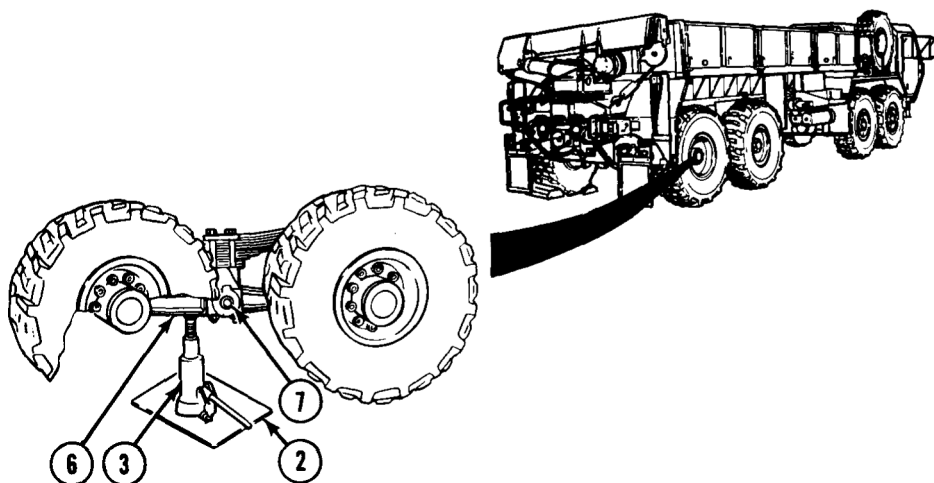

Figure 9.

4. Raise jack (3) until it touches equalizer beam (6).

REMOVE LIMP HOME SETUP FROM PASSENGER SIDE FRONT OR ANY REAR WHEEL - Continued

Figure 10.

5. Raise jack (3) until axle (8) is as close as it will go to axle stop (9).
6. Unhook 7 ft. (2.1 m) chain (10) and remove from shackle (11) and axle (8).

REMOVE LIMP HOME SETUP FROM PASSENGER SIDE FRONT OR ANY REAR WHEEL - Continued

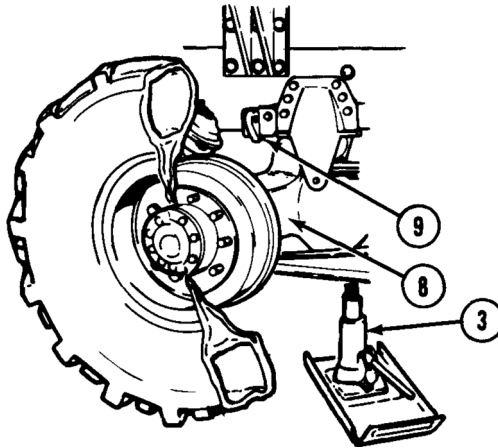
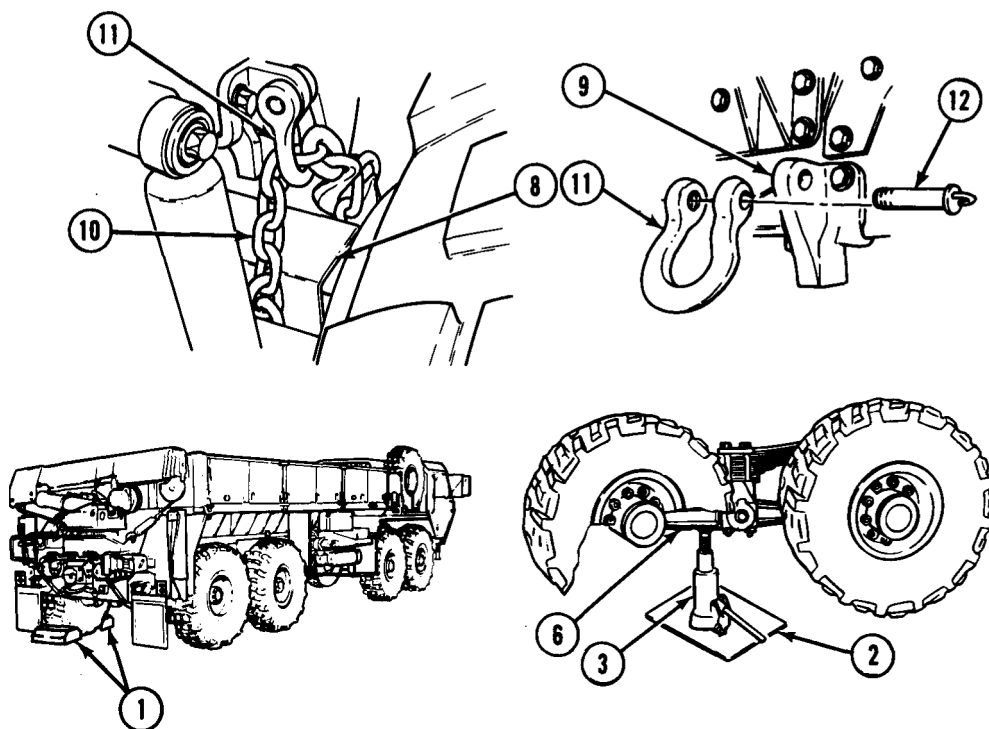

Figure 11.

7. Remove pin (12) from shackle (11) and axle stop (9).
8. Remove shackle (11) from axle stop (9) and reinstall pin (12) in shackle (11).
9. Lower jack (3) and remove jack (3) from equalizer beam (6).
10. Return jack base plate (2), jack (3), 7 ft. (2.1 m) chain (10), and shackle (11) to stowage.
11. Remove and stow two wheel chocks (1).

INSTALL LIMP HOME SETUP/DRIVER SIDE FRONT

CAUTION

- Do not use this procedure on fully loaded M983 vehicle with trailer in tow. Limp home setup will not support extra weight and equipment could be damaged.

INSTALL LIMP HOME SETUP/DRIVER SIDE FRONT - Continued

- Vehicle must not be driven faster than 10 mph (16 km/h) or farther than 30 miles (48 km) in limp home condition.

NOTE

- Use limp home procedure for emergency only in case of wheel bearing failure, wheel damage, or when unable to change wheel and tire.
 - Limp home setup No. 1 axle is shown. Setup for No. 2 axle is done in same manner.
 - For limp home setup on other axles, refer to passenger side front or any rear wheel section above.
1. Remove two wheel chocks (1), jack base plate (2), jack (3), and 7 ft. (2.1 m) chain (4) from stowage.

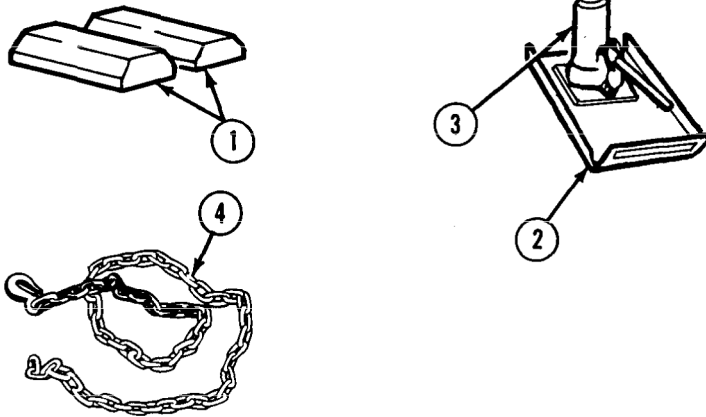
*Figure 12.*

2. Install two wheel chocks (WP 0077) (1) in front of and behind tire (5) across from tire (6) being raised.

INSTALL LIMP HOME SETUP/DRIVER SIDE FRONT - Continued

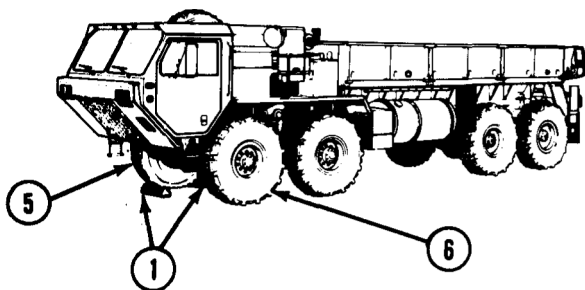

Figure 13.

3. Place jack base plate (2) and jack (3) under end of equalizer beam (7).

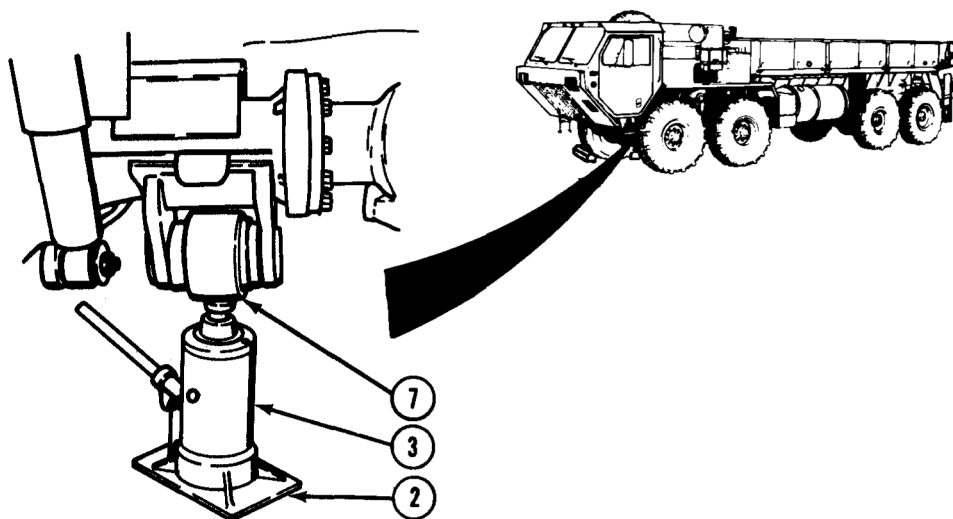

Figure 14.

4. Raise jack (3) until it touches end of equalizer beam (7).
5. Raise jack (3) until axle (8) is as close as it will go to axle stop (9).

INSTALL LIMP HOME SETUP/DRIVER SIDE FRONT - Continued

Figure 15.

CAUTION

Do not wrap 7 ft. (2.1 m) chain around lateral torque rod or shift cables as they could be crushed. Failure to comply may result in damage to equipment.

6. Loop end of 7 ft. (2.1 m) chain (4) around frame (10) and axle (8).

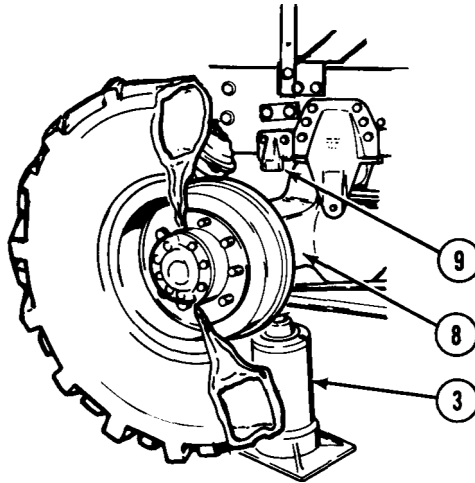
INSTALL LIMP HOME SETUP/DRIVER SIDE FRONT - Continued

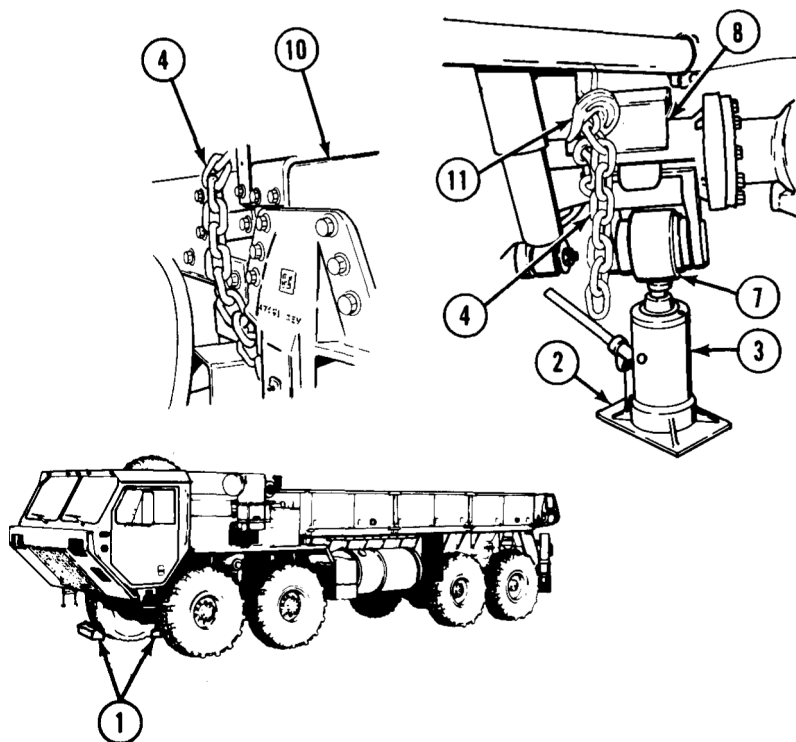

Figure 16.

WARNING

Keep hands away from chain when lowering jack. Hands and fingers could be crushed. Failure to comply may result in injury or death to personnel.

7. Bring end of 7 ft. (2.1 m) chain (4) up to chain hook (11) and fasten back into itself as tight as possible.

NOTE

Axle will drop slightly when jack is lowered.

8. Lower jack (3) and remove jack (3) from end of equalizer beam (7).

INSTALL LIMP HOME SETUP/DRIVER SIDE FRONT - Continued

9. Return jack base plate (2), and jack (3) to stowage.
10. Remove and stow two wheel chocks (1).

REMOVE LIMP HOME SETUP/DRIVER SIDE FRONT

1. Remove two wheel chocks (1), jack base plate (2), and jack (3) from stowage.

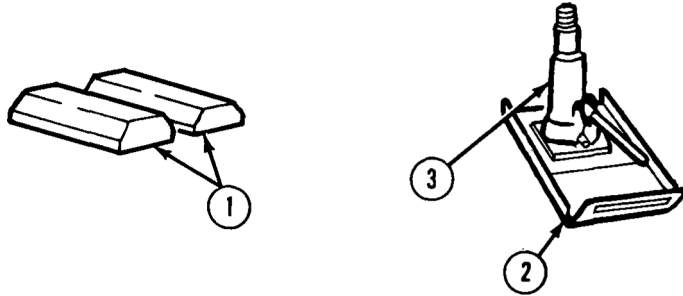
*Figure 17.*

2. Install two wheel chocks (1) in front of and behind tire (4) across from tire (5) being raised.

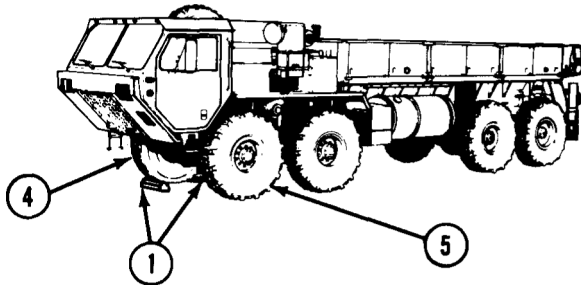
*Figure 18.*

3. Place jack base plate (2) and jack (3) under end of equalizer beam (6).

REMOVE LIMP HOME SETUP/DRIVER SIDE FRONT - Continued

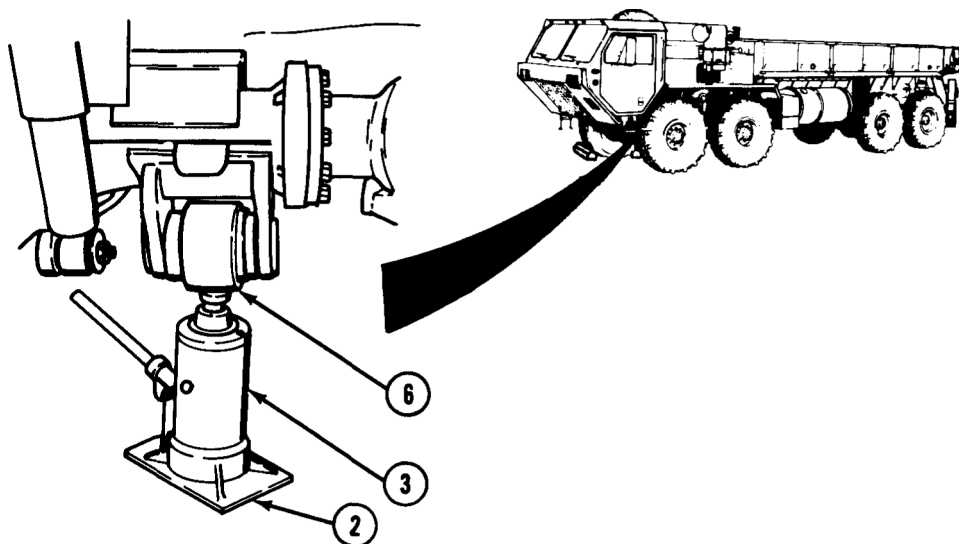

Figure 19.

4. Raise jack (3) until it touches end of equalizer beam (6).
5. Raise jack (3) until axle (7) is as close as it will go to axle stop (8).

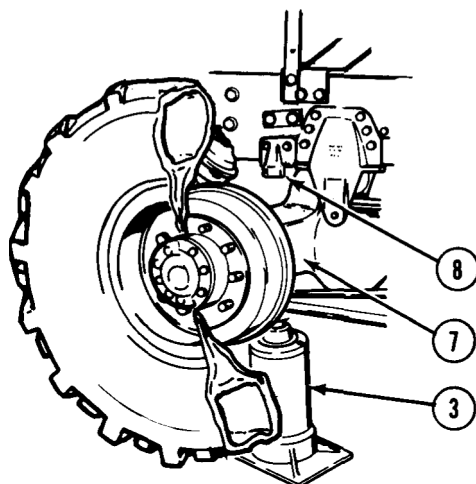
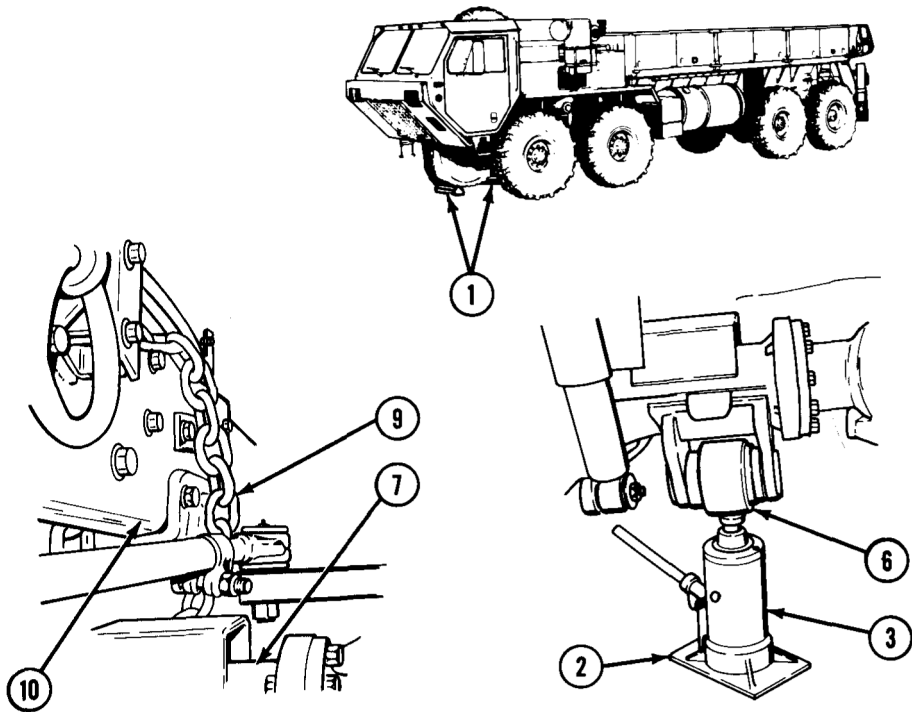

Figure 20.

6. Unhook 7 ft. (2.1 m) chain (9) and remove from around frame (10) and axle (7).

REMOVE LIMP HOME SETUP/DRIVER SIDE FRONT - Continued*Figure 21.*

7. Lower jack (3) and remove jack from equalizer beam (6).
8. Return jack base plate (2), jack (3), and 7 ft. (2.1 m) chain (9) to stowage.
9. Remove and stow two wheel chocks (1).

END OF TASK**END OF WORK PACKAGE**

OPERATOR MAINTENANCE
PERFORM IMMEDIATE ACTION FOR LOSS OF AIR SUPPLY SYSTEM PRESSURE

INITIAL SETUP:

Not Applicable

PERFORM PROCEDURE

1. If AIR indicator (1) illuminates and warning buzzer sounds while driving vehicle, check AIR PRESS gauge (2).

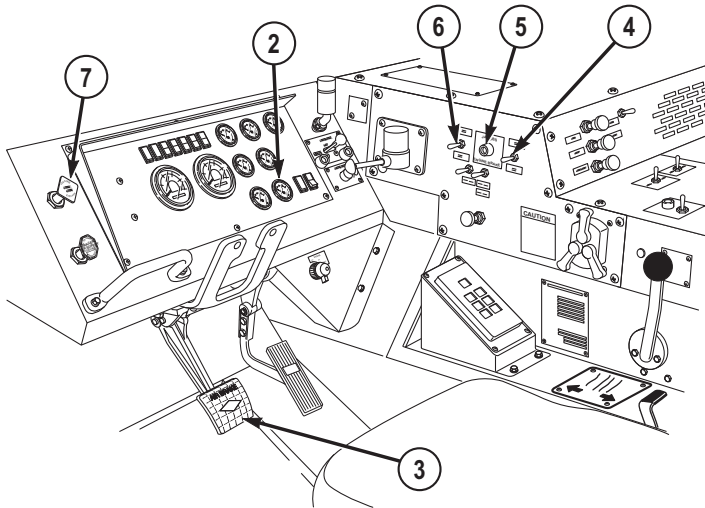

Figure 1.

NOTE

If both red needle and green needle on AIR PRESS gauge read zero, skip to Step (4).

2. If red pointer on AIR PRESS gauge (2) is at zero and green needle shows normal air pressure of 100 to 120 psi (690 to 827 kPa), complete the following:
 - a. Continue operation of vehicle. Brakes on all eight wheels and trailer will work even if air pressure from No. 2 air tank has been lost.
 - b. Notify field level maintenance as soon as possible.

PERFORM PROCEDURE - Continued**WARNING**

When green pointer of AIR PRESS gauge is at zero, braking capability is greatly reduced. Extra care must be used to avoid collision. Failure to comply may result in injury or death to personnel.

NOTE

If both red needle and green needle on AIR PRESS gauge read zero, skip to Step (4).

3. If green needle on AIR PRESS gauge (2) is at zero and red needle shows normal air pressure of 100 to 120 psi (690 to 827 kPa), complete the following:
 - a. Continue operation of vehicle. Brakes on third and fourth axles and trailer will work even if air pressure from No. 3 air tank has been lost.
 - b. Leave additional distance between vehicles.
 - c. Apply service brake pedal (3) earlier than usual when slowing vehicle.
 - d. Downshift as necessary, when slowing vehicle.

WARNING

Do not use engine brake when vehicle is on slippery surface. If engine brake is used incorrectly, vehicle may skid out of control. Failure to comply may result in injury or death to personnel.

- e. If necessary to slow vehicle, set Jacobs engine brake HIGH/LOW switch (6) to LOW and set ON/OFF switch (7) to ON.
 - f. Notify field level maintenance as soon as possible.
4. If both red needle and green needle on AIR PRESS gauge (2) read zero, complete the following:
 - a. Downshift as needed to control vehicle speed until place is found to stop.

PERFORM PROCEDURE - Continued**WARNING**

Use of service brake pedal will not slow or stop vehicle when both pointers of AIR PRESS gauge read zero. Use the following procedure to safely stop vehicle after loss of air pressure. Failure to comply may result in injury or death to personnel.

NOTE

When spring brakes are applied, vehicle will stop quickly. Vehicle cannot be driven again until malfunction is repaired and there is enough air supply for operation of service brakes.

- b. Look for place to stop vehicle without blocking other traffic.
- c. When suitable area is found to stop vehicle, pull out PARKING BRAKE control (8) to apply spring brakes on four rear wheels.
- d. Notify field level maintenance.

END OF TASK**END OF WORK PACKAGE**

OPERATOR MAINTENANCE INSTALL/REMOVE TIRE CHAINS

INITIAL SETUP:

Personnel Required

Operator and Assistant - - - (2)

INSTALL TIRE CHAINS

CAUTION

When tire chains are used, they must be used on all four rear wheels. Chains must not be used when driving on hard surfaces where there is no wheel slippage. Improper use of tire chains may result in equipment damage.

NOTE

- This procedure is a two soldier task.
 - Tire chains on No. 3 and No. 4 axle tires are all installed the same. Passenger side No. 4 axle shown.
 - Maximum speed limit for vehicles driving with chains in city or on highway is 10 mph (16 km/h).
 - Maximum speed limit for vehicles driving with chains off-road is 15 mph (24 km/h).
1. With aid of an assistant, place tire chain (1) on ground with cross chain connecting links (2) facing down.

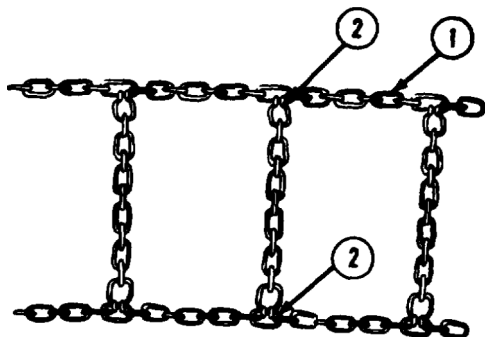
INSTALL TIRE CHAINS - Continued*Figure 1.***NOTE**

Assistant shall ensure vehicle is stopped when only tire in contact with tire chains is tire being equipped.

2. Move vehicle onto tire chain (1) while assistant guides vehicle so tire (3) is about one-third of way on tire chain.

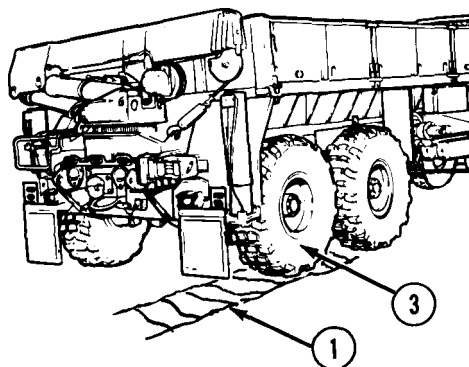
*Figure 2.***NOTE**

Ensure only tire in contact with tire chains is tire being equipped.

3. Park vehicle. (WP 0056)
4. With aid of an assistant, wrap tire chain (1) around tire (3).

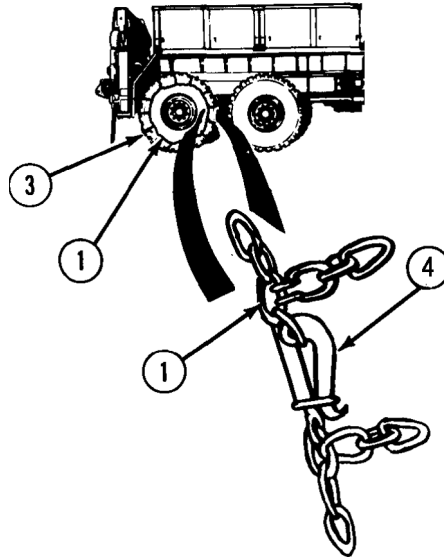
INSTALL TIRE CHAINS - Continued*Figure 3.*

5. With aid of an assistant, connect and secure inside and outside clamps (4) so tire chain (1) is as tight as possible.
6. With aid of an assistant, repeat Steps (1) through (5) on remaining tires of No. 3 and No. 4 axles.
7. Drive vehicle forward (WP 0050) about 15 ft. (4.6 m) and then drive vehicle in reverse (WP 0051) about 15 ft. (4.6 m) as guided by assistant.
8. Park vehicle. (WP 0056)

NOTE

Tire chains on No. 3 and No. 4 axle tires are all tightened up the same.
 Passenger side No. 4 axle shown.

9. With aid of an assistant, disconnect inside clamp (4) of tire chain (1) on tire (3).

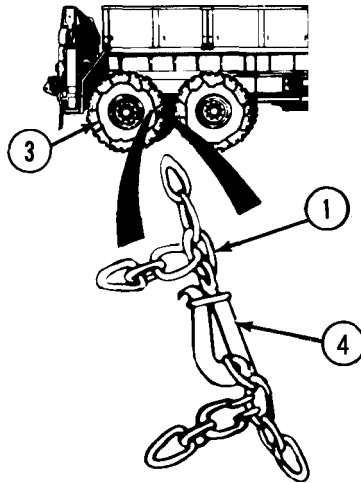
INSTALL TIRE CHAINS - Continued*Figure 4.*

10. With aid of an assistant, take up slack in tire chain (1).
11. With aid of an assistant, connect inside clamp (4).
12. With aid of an assistant, disconnect outside clamp (4) of tire chain (1) on tire (3).
13. With aid of an assistant, take up slack in tire chain (1).
14. With aid of an assistant, connect outside clamp (4).
15. With aid of an assistant, take up slack in tire chains on other three rear tires by repeating Steps (10) through (15).

REMOVE TIRE CHAINS**NOTE**

- This procedure is a two soldier task.
- Tire chains on No. 4 axle tires are both removed the same. Passenger side shown.

1. Move vehicle into position so tire chain (1) and clamps (2) on tire (3) are at 4 o'clock position while assistant guides vehicle.

REMOVE TIRE CHAINS - Continued

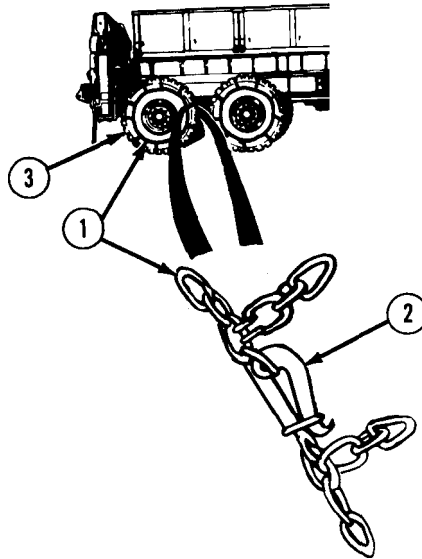

Figure 5.

2. Park vehicle. (WP 0056)
3. With aid of an assistant, disconnect inside and outside clamps (2) of tire chain (1).

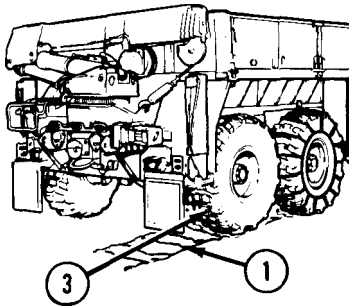

Figure 6.

4. With aid of an assistant, unwrap tire chain (1) from tire (3) and spread tire chain out on ground behind vehicle.
5. Drive vehicle forward (WP 0050) off tire chain (1) while assistant guides vehicle.
6. With aid of an assistant, repeat Steps (2) through (5) for opposite side tire.

REMOVE TIRE CHAINS - Continued**NOTE**

Tire chains on No. 3 axle tires are both removed the same. Passenger side shown.

7. Move vehicle into position so tire chain (4) and clamps (5) on tire (6) are at 8 o'clock position while assistant guides vehicle.

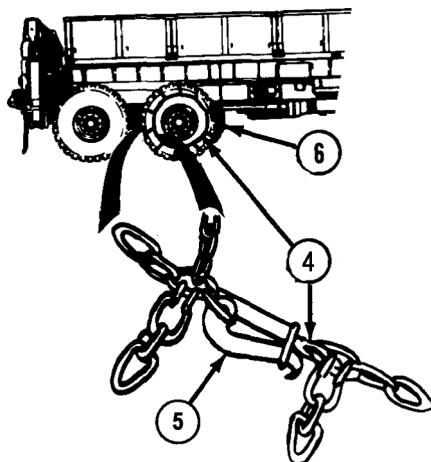

Figure 7.

8. Park vehicle. (WP 0056)
9. With aid of an assistant, disconnect inside and outside clamps (5) of tire chain (4).
10. With aid of an assistant, unwrap tire chain (4) from tire (6) and spread tire chain out on ground in front of tire.

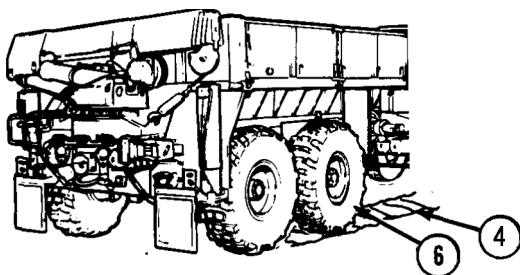

Figure 8.

11. Drive vehicle forward (WP 0050) off tire chain (4) while assistant guides vehicle.

REMOVE TIRE CHAINS - Continued

12. With aid of an assistant, repeat Steps (7) through (11) for opposite side tire.

END OF TASK

END OF WORK PACKAGE

**OPERATOR MAINTENANCE
FORD WATER OBSTACLE**

INITIAL SETUP:

Not Applicable

WARNING

Do not ford water unless depth is known. Water deeper than 4 ft. (1.2 m) may enter vehicle. Failure to comply may result in injury or death to personnel.

NOTE

After vehicle fords water obstacle, service all lubrication points below fording depth and check submerged gearboxes for presence of water upon return from mission (refer to lubrication instructions (WP 0151) for more information).

CAUTION

Towing a trailer may affect maximum fording depth (refer to applicable trailer operators manual). Do not ford water obstacle deeper than maximum depth allowed by either vehicle or trailer (whichever depth is less). Failure to comply may result in damage to equipment.

1. Ensure depth of fording site is not more than 4 ft. (1.2 m).
2. Ensure bottom at fording site is firm enough that 4 ft. (1.2 m) maximum fording depth will not be exceeded and vehicle will not become mired.
3. Stop vehicle at edge of water.
4. If brakes have been used heavily and are hot, allow drums and shoes to cool before entering water if possible.
5. Ensure engine is operating correctly before entering water.
6. Set TRANSFER CASE shift lever (1) to LO, 8X8 drive indicator (2) will illuminate.

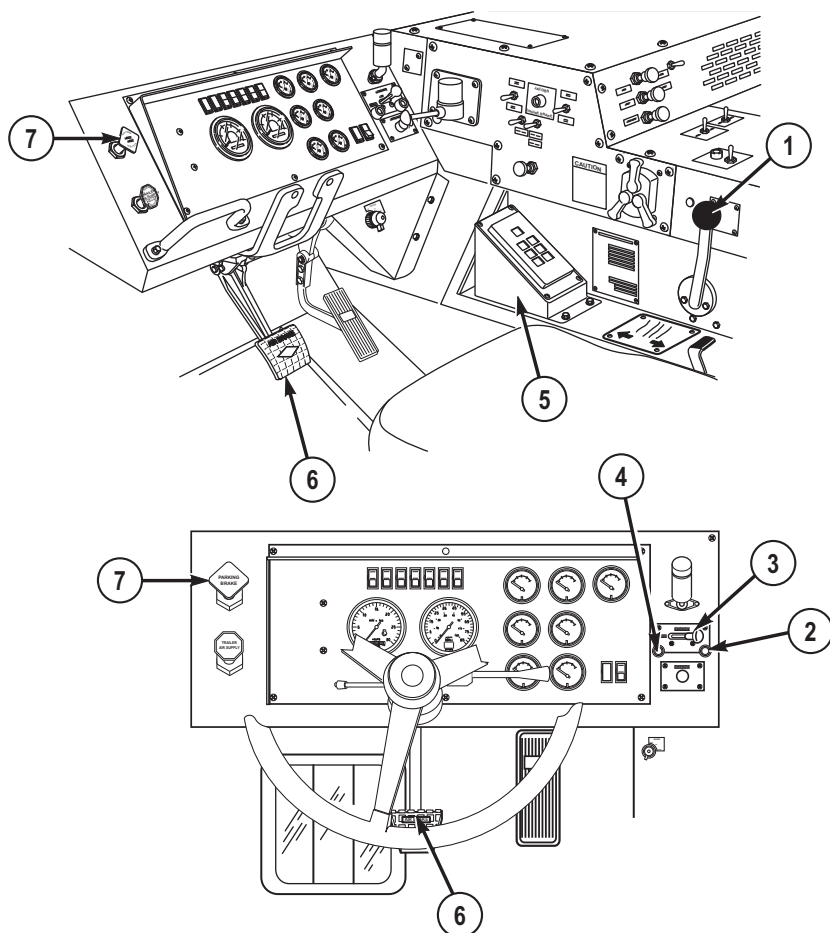

Figure 1.

7. Set TRACTION CONTROL lever (3) to INTER-AXLE DIFF. LOCK for added traction, INTER-AXLE LOCK indicator light (4) will come on.
8. Set transmission range selector (5) to 1 (1st gear range).
9. Drive vehicle slowly into water.
10. If engine stops, immediately attempt to restart engine. If engine will not start, tow or winch vehicle from water with another vehicle as soon as possible.
11. Drive vehicle at 3 to 4 mph (5 to 6 km/h) or less, through water.
12. Unless absolutely necessary, do not stop while in water.
13. If vehicle accidentally enters water deeper than 4 ft. (1.2 m), do the following:
 - a. Apply service brake pedal (6) and hold to stop vehicle.

- b. Set transmission range selector (5) to R (reverse).
 - c. Release service brake pedal (6).
 - d. Slowly back vehicle out of deep water.
14. After leaving water, lightly press service brake pedal (6) and hold while driving slowly to dry out brake linings.
 15. When clear of fording area, stop vehicle.
 16. Apply and release PARKING BRAKE control (WP 0045) (7) several times to remove water from brake components.
 17. Remove water and clean deposits from all vehicle parts as soon as possible.
 18. Deliver vehicle to field level maintenance as soon as possible.

END OF TASK

END OF WORK PACKAGE

**OPERATOR MAINTENANCE
INTERIM NUCLEAR, BIOLOGICAL, AND CHEMICAL (NBC) DECONTAMINATION
PROCEDURES**

INITIAL SETUP:

Not Applicable

INTRODUCTION AND PROCEDURES

NOTE

To reduce the effects of contamination in an NBC-contaminated environment, the HEMTT series vehicle should be operated with all windows, doors, and stowage boxes closed.

1. The HEMTT series vehicle is capable of being operated by personnel wearing nuclear, biological, or chemical (NBC) protective clothing without special tools or supporting equipment. Refer to FM 3-11.5 (WP 0161) for information on decontamination procedures. Specific procedures for the HEMTT series vehicle are as follows:
 - a. Rubber sleeves and other rubber items, rope, and gaskets will absorb and retain chemical agents. Replacement of these items is the recommended method of decontamination.
 - b. Lubricants or fluids may be present on the external surfaces of the HEMTT series vehicle or its components due to leaks or normal operation. These fluids will absorb NBC agents. The preferred method of decontamination is removal of these fluids using conventional decontamination methods in accordance with FM 3-11.5. (WP 0161)
 - c. Continued decontamination of the external HEMTT series vehicle surfaces with supertropical bleach (STB)/decontamination solution number 2 (DS2) will degrade clear plastic (e.g., hydraulic fluid reservoir sight glass) to the point where looking through it will become impossible. This problem will become more evident for soldiers wearing protective masks. Therefore, the use of STB or DS2 decontamination in the area of clear plastic should be minimized. Clear plastic should be decontaminated with warm, soapy water.
 - d. External surfaces of the HEMTT series vehicle and related equipment such as the remote control units that are marked with painted or stamped lettering will not withstand repeated decontamination with STB or DS2 without degradation of this lettering. Therefore, the recommended method of decontamination for these areas is washing with warm, soapy water.

INTRODUCTION AND PROCEDURES - Continued**NOTE**

Replacement of hardware, as well as conventional methods of decontamination, are the preferred methods of decontamination for the areas listed below.

2. Areas that will entrap contaminants, making efficient decontamination extremely difficult include the following:
 - a. Exposed heads of screws.
 - b. Areas adjacent to and behind exposed hydraulic lines.
 - c. Hinged areas or access doors on the stowage boxes.
 - d. Retaining chains for lynchpins and lockpins.
 - e. Areas around the tiedowns, lifting rings, crevices around access doors, external valves and drains, and exposed hydraulic connectors.
 - f. Areas behind knobs, levers, externally-mounted equipment, specification and advisory data plates, and roller and locking mechanisms.
 - g. Winch cable and winch hook assembly.
3. Conventional methods of decontamination should be used on all areas listed in Steps (1) and (2), while stressing the importance of thoroughness, and the probability of some degree of continuing contact, including vapor hazard.
4. For additional NBC information, refer to FM 3-11.3 (WP 0161) and FM 3-11.4. (WP 0161)

END OF TASK**END OF WORK PACKAGE**

OPERATOR MAINTENANCE SELF-RECOVER VEHICLE USING SELF-RECOVERY WINCH

INITIAL SETUP:

Personnel Required

Operator and Assistant - - - (2)

WINCH MIRED VEHICLE FORWARD

NOTE

- For additional information on vehicle self-recovery, refer to FM 4-30.31. (WP 0161)
 - Vehicle self-recovery is a two soldier task. Soldiers must communicate by hand signals.
1. Shut off engine. (WP 0057)
 2. Adjust mirror (1) so assistant can be clearly seen during procedure.

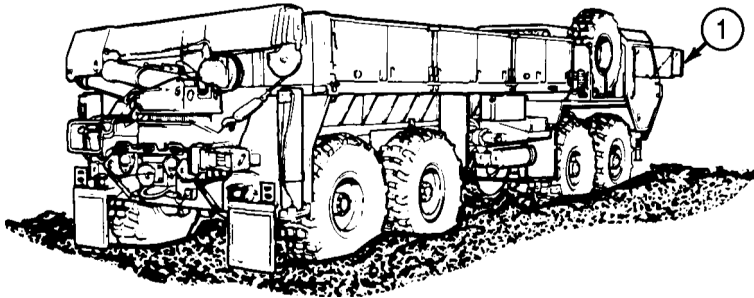

Figure 1.

CAUTION

PTO ENGAGE switch must be in OFF position before moving hydraulic selector valve control to prevent equipment damage.

3. Set PTO ENGAGE switch (2) to OFF position. Indicator light (3) will go out.

WINCH MIRED VEHICLE FORWARD - Continued

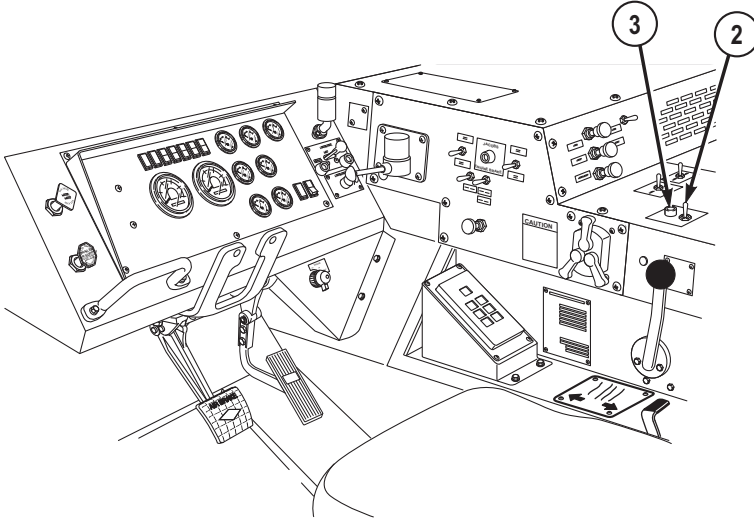
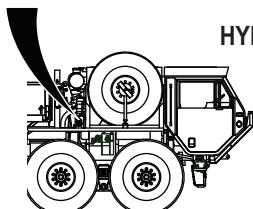
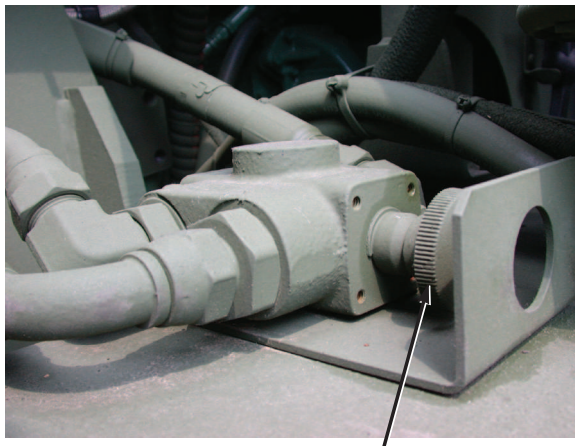

Figure 2.

4. Pull out hydraulic selector valve control.

WINCH MIRED VEHICLE FORWARD - Continued

**HYDRAULIC SELECTOR
VALVE CONTROL**

Figure 3.

5. Start engine. (WP 0044)
6. Set PTO ENGAGE switch (2) to ON position. Indicator light (3) will illuminate.

WINCH MIRED VEHICLE FORWARD - Continued

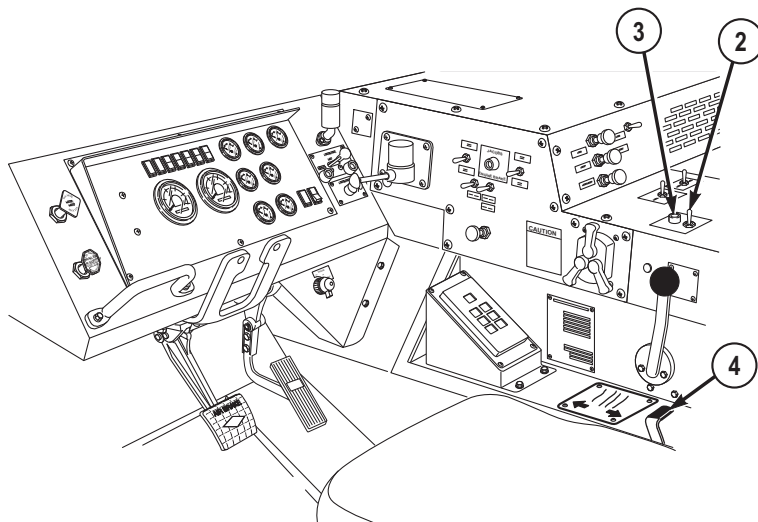

Figure 4.

7. Move winch shift lever (4) to OUT position to pay out small amount of cable.
8. Release winch shift lever (4) to center position.
9. Set PTO ENGAGE switch (2) to OFF position. Indicator light (3) will go out.
10. Remove cotter pin (5) from pin (6).

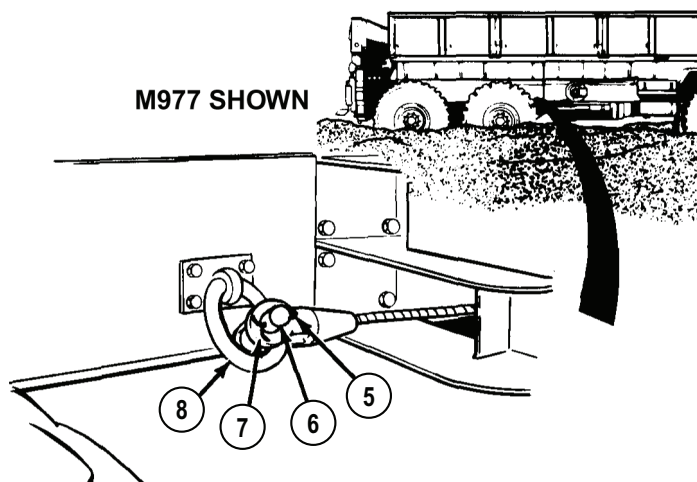

Figure 5.

WINCH MIRED VEHICLE FORWARD - Continued

11. Remove pin (6) from clevis (7) and disconnect clevis (7) from tiedown ring (8).

WARNING

- Always wear protective gloves when handling winch cable. Never let cable run through hands. Frayed cables can cut severely. Failure to comply may result in injury or death to personnel.
 - Never operate winch with less than five wraps of cable on winch drum. Failure to comply may result in injury or death to personnel.
12. Route winch cable (9) around, and over top of winch (10) toward front of vehicle (as shown).

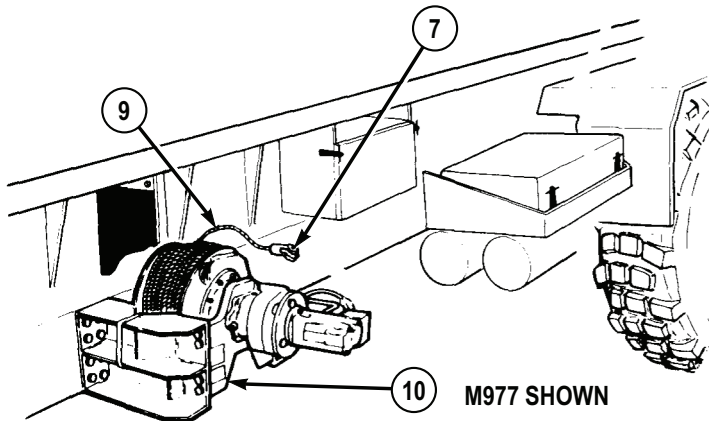

Figure 6.

13. Set PTO ENGAGE switch (2) to ON position. Indicator light (3) will illuminate.

WINCH MIRED VEHICLE FORWARD - Continued

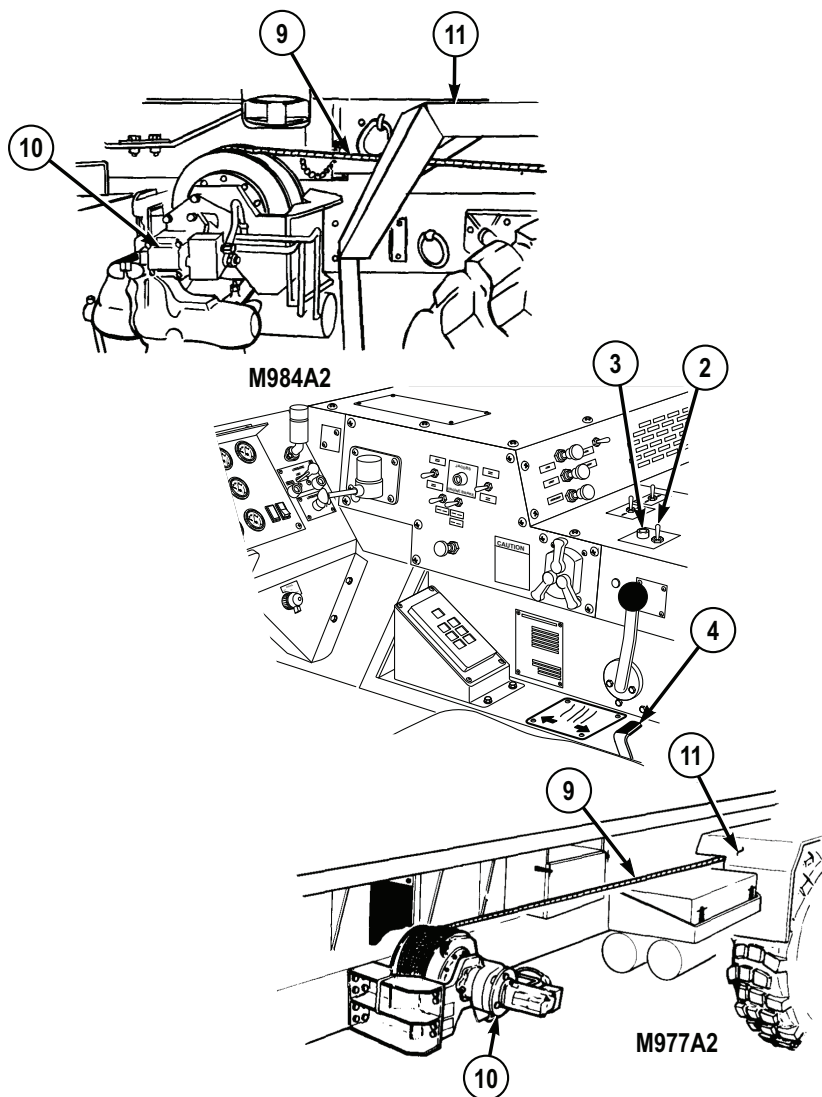

Figure 7.

14. Move winch shift lever (4) to OUT and pay out winch cable (9), while assistant routes cable (9) through notch in fender (11).

NOTE

- Do not place cable between tensioning device pulleys at this time.

WINCH MIRED VEHICLE FORWARD - Continued

- When pulling cable through tensioning device, push sheave towards frame rail to allow clevis to pass through.

15. Pay out cable (9) while assistant pulls cable (9) until it is 6 in. to 1 ft. (15 cm to 30 cm) past the front roller guide (12).

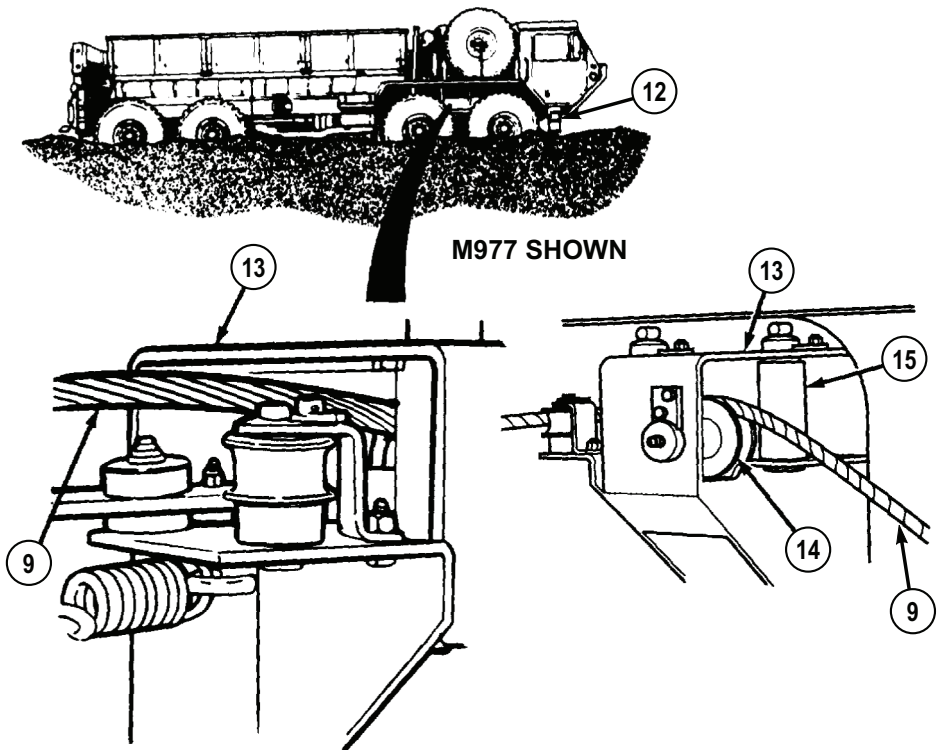

Figure 8.

16. Stop paying out cable (9).
17. Assistant routes cable (9) through cable guide (13), over sheave (14), between roller (15), and side of cable guide (13).
18. Pay out winch cable (9) as assistant routes cable over first axle and 1 ft. (30 cm) past front roller guide assembly (12).

WINCH MIRED VEHICLE FORWARD - Continued

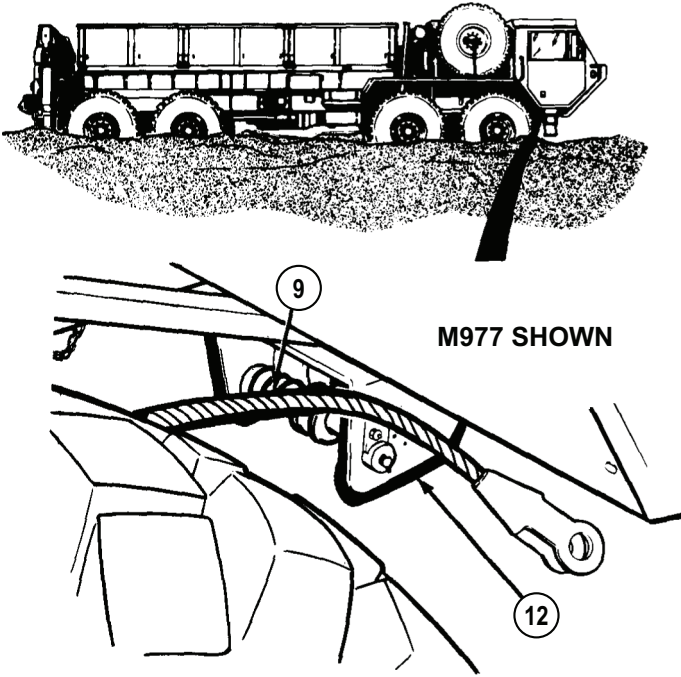

Figure 9.

19. Release winch shift lever (4) to center position.

WINCH MIRED VEHICLE FORWARD - Continued

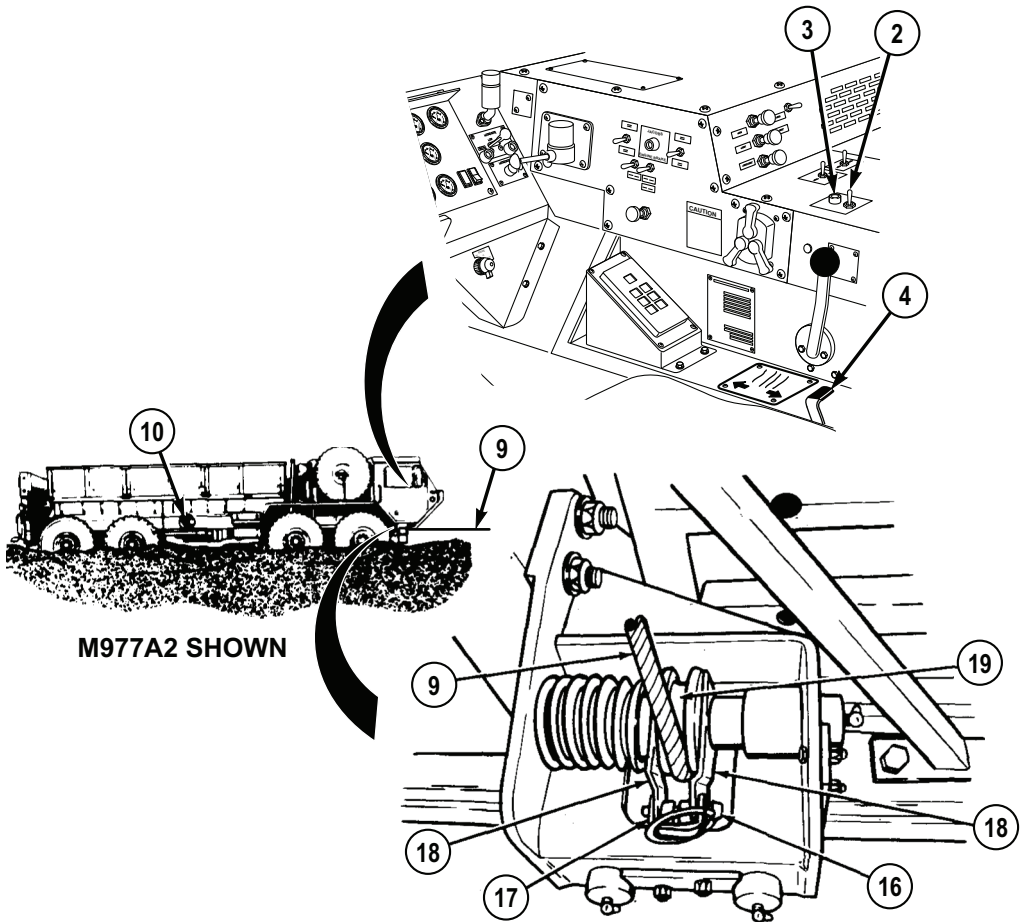

Figure 10.

20. Set PTO ENGAGE switch (2) to OFF position. Indicator light (3) will go out.
21. Remove quick release pin (16) and guide bracket (17). Move cable guide brackets (18) apart so cable (9) can be placed against bottom of sheave (19).
22. Move cable guide brackets (18) together and install guide bracket (17) and quick release pin (16).
23. Set PTO ENGAGE switch (2) to ON position. Indicator light (3) will illuminate.
24. Move winch shift lever (4) to OUT and pay out winch cable (9) while assistant pulls cable to tree, another heavy vehicle (WP 0089), or another heavy object refer to FM 4-30.31. (WP 0161)

WINCH MIRED VEHICLE FORWARD - Continued

25. When winch cable (9) is let out to heavy object, release winch shift lever (4) to center position.
26. Set PTO ENGAGE switch (2) to OFF position. Indicator light (3) will go out.
27. If snatch block must be used for self-recovery operation, attach self-recovery winch cable (9) to snatch block (WP 0088) and connect end of self-recovery winch cable to mired vehicle left front towing eye. (WP 0089) Attach snatch block to tree, another vehicle, or heavy object refer to FM 4-30.31. (WP 0161)

CAUTION

There must always be at least five wraps of cable on winch. If load is applied with less than five wraps of cable on winch, cable may come loose on drum.

28. Check that there are at least five wraps of winch cable (9) left on winch (10). If there are not at least five wraps of winch cable left on self-recovery winch, stop using self-recovery winch and continue with Step (54) of this procedure.

CAUTION

Do not go over winch pull capacity or winch may be damaged.

29. Ensure weight of mired vehicle and amount of winch cable (9) left on self-recovery winch (10) does not go over pull capacity (refer to FM 4-30.31 (WP 0161) and Self-Recovery Winch Pull Capacity table below). If pull will go over capacity, stop using self-recovery winch and continue with Step (54) of this procedure.

Table 1. Self-Recovery Winch Pull Capacity.

Cable Layer	Maximum Line Pull
1st layer (five wraps)	20,000 lbs (9 080 kg)
2nd layer	18,173 lbs (8 251 kg)
3rd layer	16,663 lbs (7 565 kg)
4th layer	15,361 lbs (6 974 kg)
5th layer	14,254 lbs (6 471 kg)

NOTE

If winch cable will be connected to another vehicle acting as a stationary anchor, refer to FM 4-30.31 (WP 0161) or Connect/Disconnect Self-

WINCH MIRED VEHICLE FORWARD - Continued

Recovery Winch Cable to Another Vehicle (WP 0089) for connecting procedures.

30. If it is determined using self-recovery winch (10) will not go over winch pull capacity, connect winch cable (9) to heavy object.
31. Ensure winch shift lever (4) is at center position.
32. Ensure PTO ENGAGE switch (2) is set to OFF position. Indicator light (3) will go out.

WARNING

Do not operate winch while personnel are working on or around tensioning device. Failure to comply may result in injury or death to personnel.

33. Pull back and hold tension pulley lever (20).

WINCH MIRED VEHICLE FORWARD - Continued

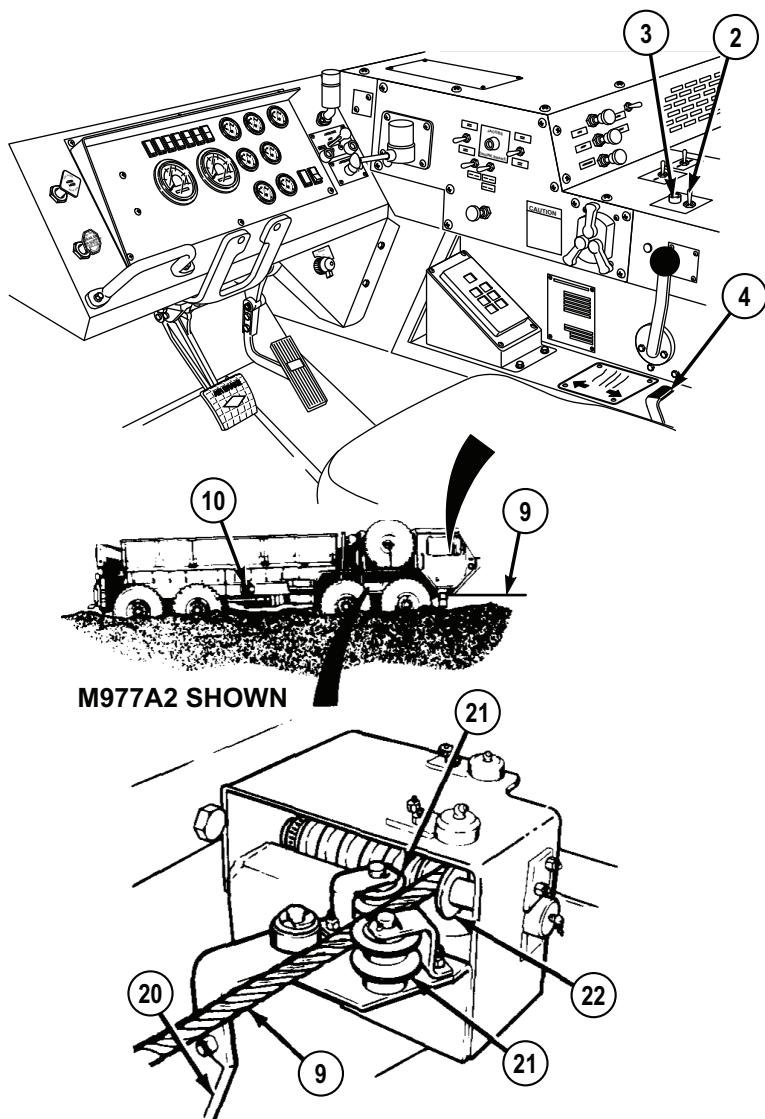

M977A2 SHOWN

Figure 11.

34. Put winch cable (9) between tensioning device pulleys (21).
35. Release tension pulley lever (20).
36. Check that winch cable (9) rests inside grooves of both tensioning device pulleys (21) and sheave (22).

WINCH MIRED VEHICLE FORWARD - Continued

37. Check that winch cable (9) is not caught on vehicle or any other objects.

WARNING

Keep all personnel clear of area near winch cable when tension is on cable. Failure to comply may result in injury or death to personnel.

38. Ensure all personnel are clear of self-recovery winch (10) and winch cable (9).
39. Set PTO ENGAGE switch (2) to ON position. Indicator light (3) will illuminate.
40. Move winch shift lever (4) to IN until slack is out of cable.
41. Release winch shift lever (4) to center position.

WARNING

Keep all personnel clear of area near winch cable when tension is on cable. Failure to comply may result in injury or death to personnel.

CAUTION

- Self-recovery winch is not designed to winch mired vehicle by itself. Mired vehicle drive system power must always be used with winch to self-recover vehicle, or damage to equipment can result.
 - If winch does not move mired vehicle, stop using winch, overheat damage may result.
42. Ensure TRANSFER CASE shift lever (23) is set to LO.

WINCH MIRED VEHICLE FORWARD - Continued

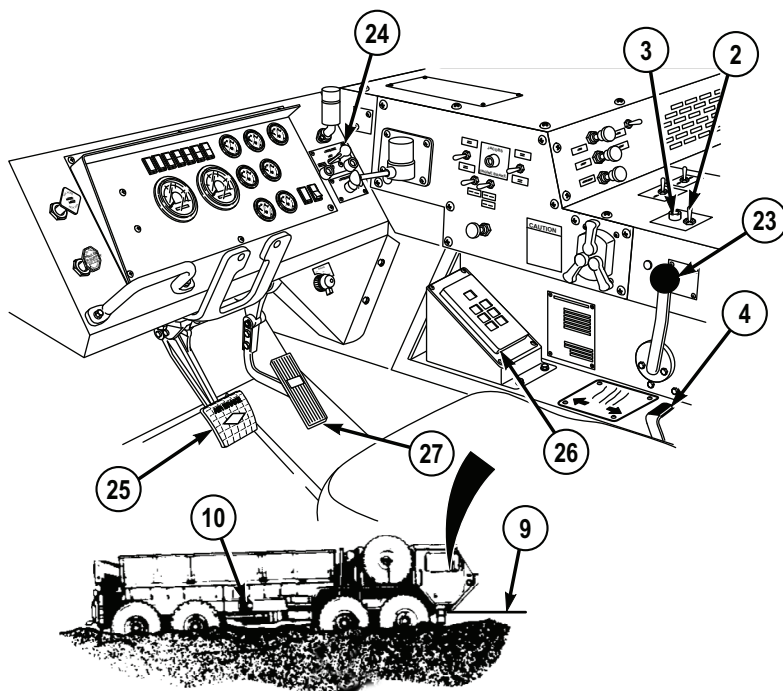

M977A2 SHOWN

Figure 12.

43. Ensure TRACTION CONTROL lever (24) is set to INTER-AXLE DIFF. LOCK.
44. Apply service brake pedal (25).
45. Set transmission range selector (26) to 1 (1st gear range).
46. Release service brake pedal (25).
47. Move winch shift lever (4) to IN and apply slight pressure to throttle pedal (27).

NOTE

Keep winch cable tight at all times so cable does not get tangled with vehicle.

48. Adjust position of throttle pedal (27) to change engine speed as needed to keep winch cable (9) tight and vehicle moving.
49. When mired vehicle is on solid ground, release winch shift lever (4) to center position.
50. Park vehicle. (WP 0056)

WINCH MIRED VEHICLE FORWARD - Continued

51. Set winch shift lever (4) to OUT and pay out winch cable (9) until all tension is off cable.
52. When all tension is off winch cable (9), release winch shift lever (4) to center position.
53. Set PTO ENGAGE switch (2) to OFF position. Indicator light (3) will go out.

NOTE

If winch cable is connected to another vehicle, refer to Connect/ Disconnect Self-Recovery Winch Cable to Another Vehicle (WP 0089) for disconnecting procedures.

54. Disconnect winch cable (9) from heavy object.
55. If snatch block was used, disconnect end of winch cable (10) from vehicle and remove snatch block from winch cable and from tree, other vehicle, or heavy object refer to FM 4-30.31. (WP 0161)

CAUTION

Do not reel clevis end of winch cable through roller guides. Clevis may catch on roller guide and cause cable or roller guide to break.

56. Set PTO ENGAGE switch (2) to ON position. Indicator light (3) will illuminate.
57. Move winch shift lever (4) to IN.

WARNING

- Always wear protective gloves when handling winch cable. Never let cable run through hands. Frayed cables can cut severely. Failure to comply may result in injury or death to personnel.
 - Never operate winch with less than five wraps of cable on winch drum. Failure to comply may result in injury or death to personnel.
58. Reel in winch cable (9) while assistant uses tire iron extension handle to guide cable (9) onto self-recovery winch (10) so cable wraps are level across face of self-recovery winch (10).
 59. When end of cable (9) is near front of vehicle, release winch shift lever (4) to center position.
 60. Set PTO ENGAGE switch (2) to OFF position. Indicator light (3) will go out.

WINCH MIRED VEHICLE FORWARD - Continued

61. Remove quick release pin (16) and guide bracket (17). Move cable guide brackets (18) apart so winch cable (9) can be removed from sheave (19).

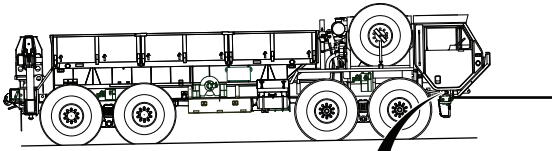

M977 SHOWN

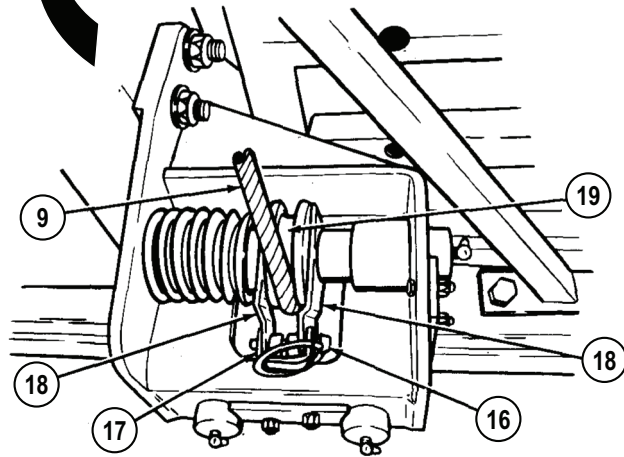
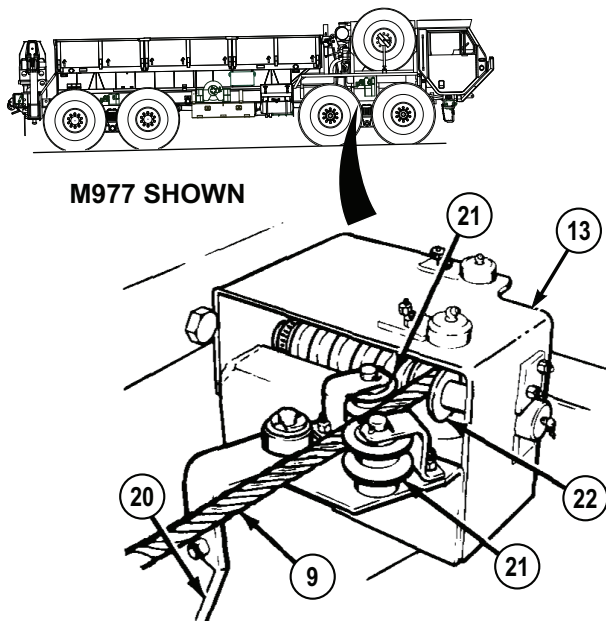

Figure 13.

62. Move cable guide bracket (18) together. Install guide bracket (17) and quick release pin (16).
63. Pull back and hold tension pulley lever (20).

WINCH MIRED VEHICLE FORWARD - Continued**M977 SHOWN***Figure 14.*

64. Lift winch cable (9) out of tensioning device pulleys (21).
65. Release tension pulley lever (20).
66. Pull winch cable (9) back and out of cable guide (13).
67. Set PTO ENGAGE switch (2) to ON position. Indicator light (3) will illuminate.

WINCH MIRED VEHICLE FORWARD - Continued

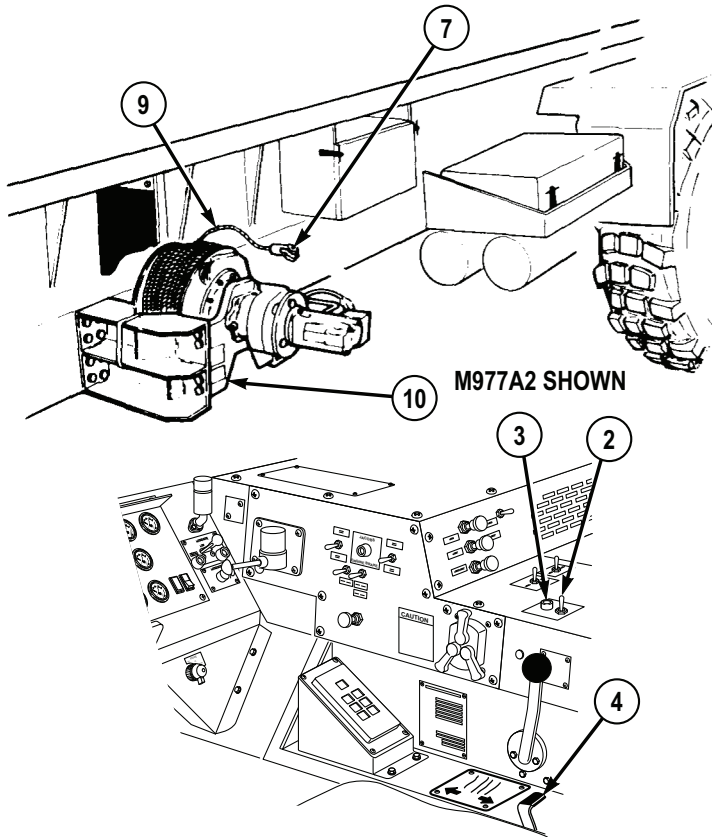

Figure 15.

68. While assistant guides winch cable (9), move winch shift lever (4) to IN.
69. When clevis (7) is approximately 2 ft. (61 cm) from winch (10), release winch shift lever (4) to center position.
70. Set PTO ENGAGE switch (2) to OFF position. Indicator light (3) will go out.
71. Assistant routes end of winch cable (9) down along front face of winch (10).

WINCH MIRED VEHICLE FORWARD - Continued

Figure 16.

72. Assistant routes end of winch cable (9) under winch (10) and out through hole in bottom of rear winch frame (28).
73. Assistant connects clevis (7) at end of winch cable (9) to tiedown ring (8) with pin (6) and cotter pin (5).

WINCH MIRED VEHICLE FORWARD - Continued

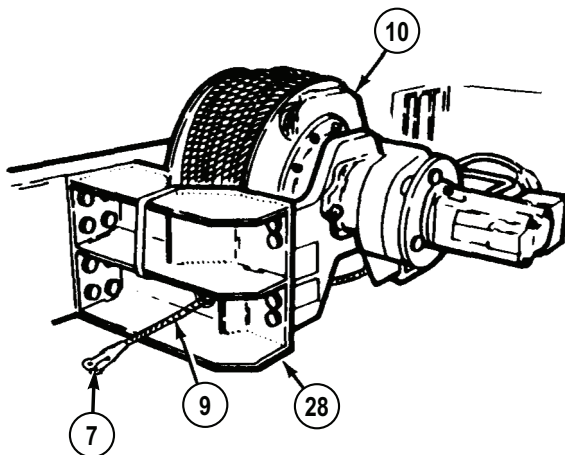
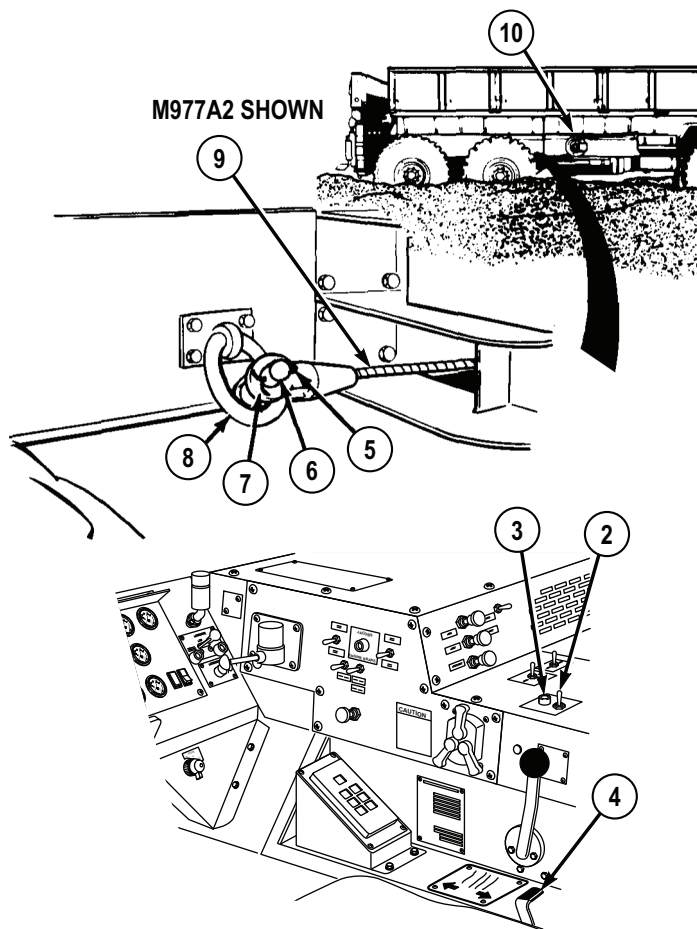

Figure 17.

74. Set PTO ENGAGE switch (2) to ON position. Indicator light (3) will illuminate.

WARNING



Keep all personnel clear of area near winch cable when tension is on cable. Failure to comply may result in injury or death to personnel.

WINCH MIRED VEHICLE FORWARD - Continued

75. Order all personnel to stand clear of area near winch (10).

CAUTION

Do not reel in winch cable too tightly. If too much tension is applied, cable or tiedown ring can break, or winch may be damaged.

76. Once assistant and all other personnel are clear of area, move winch shift lever (4) to IN and take all slack out of winch cable (9).
77. When winch cable (9) is tight, release winch shift lever (4) to center position.
78. Set PTO ENGAGE switch (2) to OFF position. Indicator light (3) will go out.
79. Shut off engine. (WP 0057)
80. Push in hydraulic selector valve control.

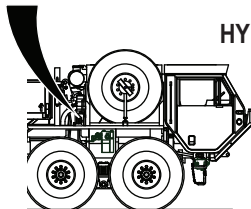
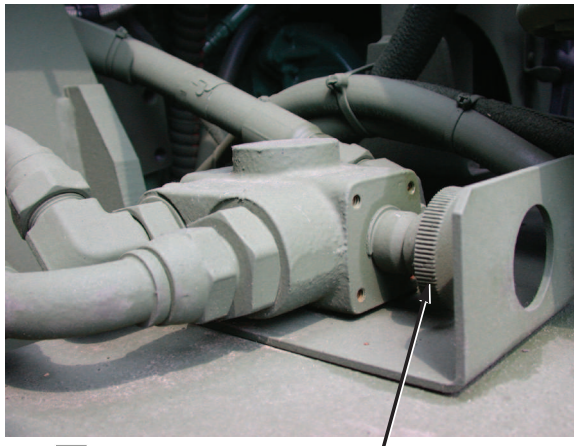

**HYDRAULIC SELECTOR
VALVE CONTROL**

Figure 18.

81. Adjust mirror (1) for driving.

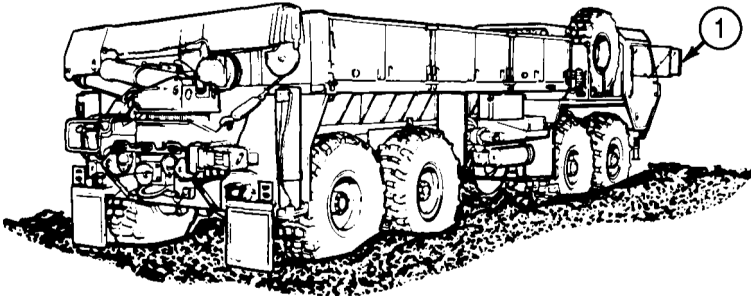
WINCH MIRED VEHICLE FORWARD - Continued*Figure 19.***WINCH MIRED VEHICLE TO THE REAR****NOTE**

- For additional information on vehicle self-recovery refer to FM 4-30.31. (WP 0161)
- Vehicle self-recovery is a two soldier task. Soldiers must communicate by hand signals.

1. Shut off engine. (WP 0057)
2. Adjust mirror (1) so assistant can be clearly seen during procedure.

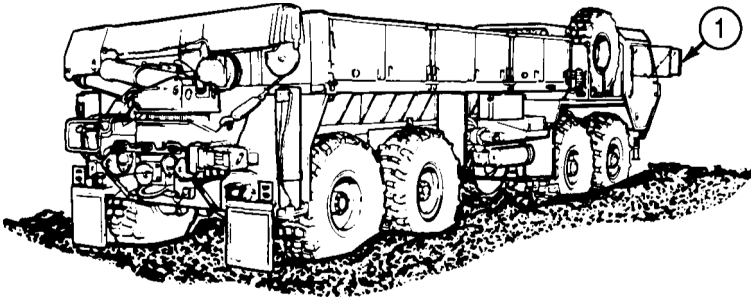
*Figure 20.*

3. Set PTO ENGAGE switch (2) to OFF position. Indicator light (3) will go out.

WINCH MIRED VEHICLE TO THE REAR - Continued

Figure 21.

4. Pull out hydraulic selector valve control.

WINCH MIRED VEHICLE TO THE REAR - Continued

**HYDRAULIC SELECTOR
VALVE CONTROL**

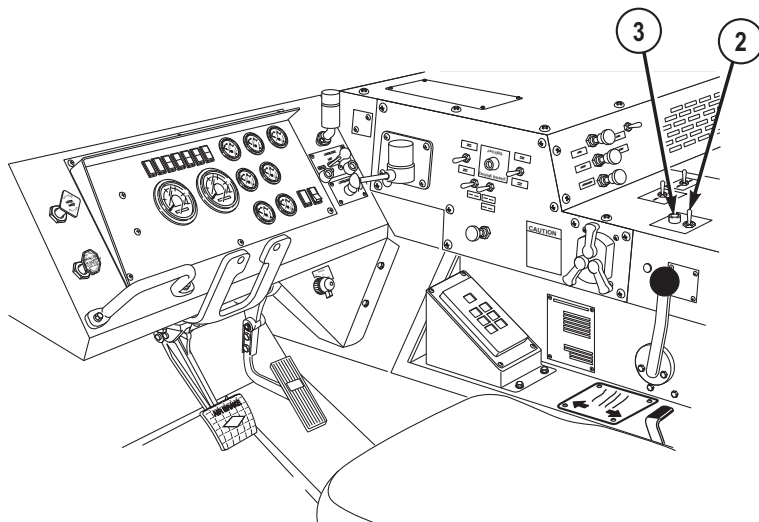
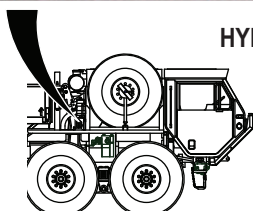
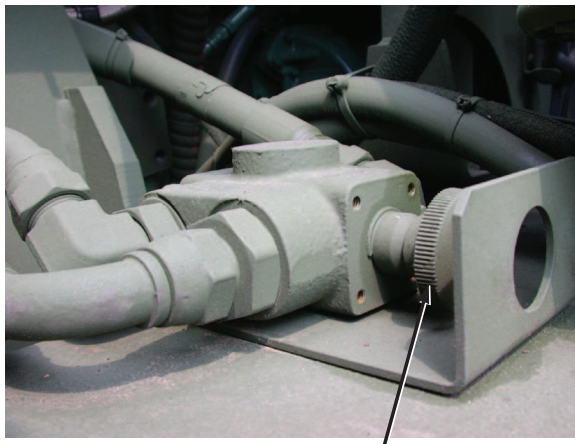
Figure 22.

5. Set PTO ENGAGE switch (2) to ON position. Indicator light (3) will illuminate.

WINCH MIRED VEHICLE TO THE REAR - Continued

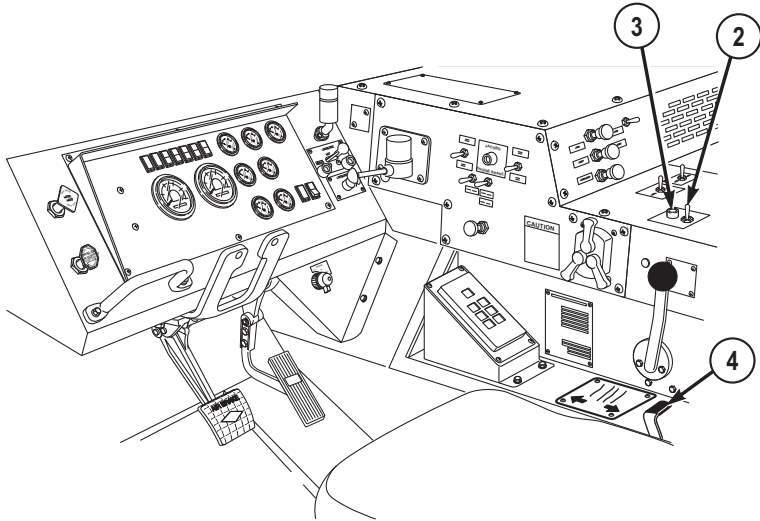

Figure 23.

6. Move winch shift lever (4) to OUT position to pay out small amount of cable.
7. Release winch shift lever (4) to center position.
8. Set PTO ENGAGE switch (2) to OFF position. Indicator light (3) will go out.
9. Remove cotter pin (5) from pin (6).

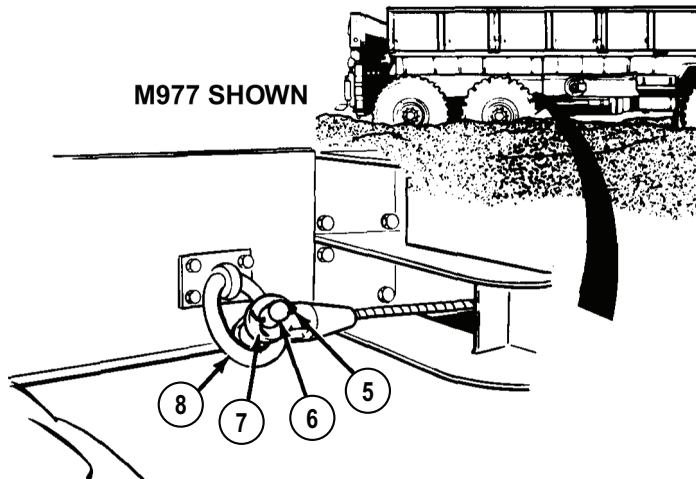

Figure 24.

WINCH MIRED VEHICLE TO THE REAR - Continued

10. Remove pin (6) from clevis (7) and disconnect clevis from tiedown ring (8).
11. Set PTO ENGAGE switch (2) to ON position. Indicator light (3) will illuminate.

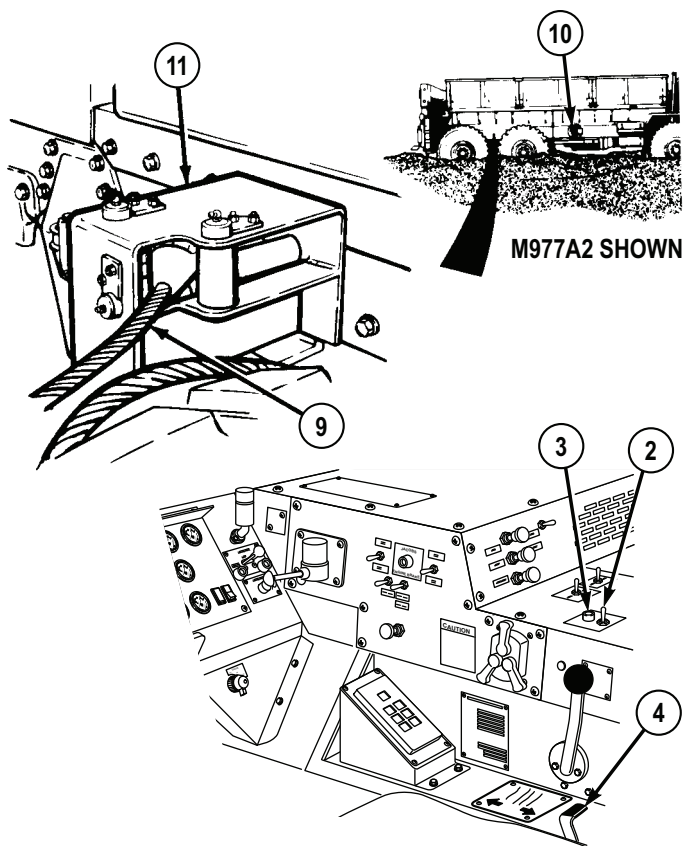

Figure 25.

WARNING

- Always wear protective gloves when handling winch cable. Never let cable run through hands. Frayed cables can cut severely. Failure to comply may result in injury or death to personnel.

WINCH MIRED VEHICLE TO THE REAR - Continued

- Never operate winch with less than five wraps of cable on winch drum. Failure to comply may result in injury or death to personnel.
12. Move winch shift lever (4) to OUT while assistant pulls winch cable (9) from self-recovery winch (10) toward rear of vehicle.

NOTE

- Do not place cable between tensioning device pulleys at this time.
 - When pulling cable through tensioning device, push sheave towards frame rail to allow clevis to pass through.
13. Continue to pay out winch cable (9) while assistant routes cable through cable guide (11).
 14. Continue to pay out winch cable (9) while assistant routes cable through hole (12) in fender and through roller guide (13).

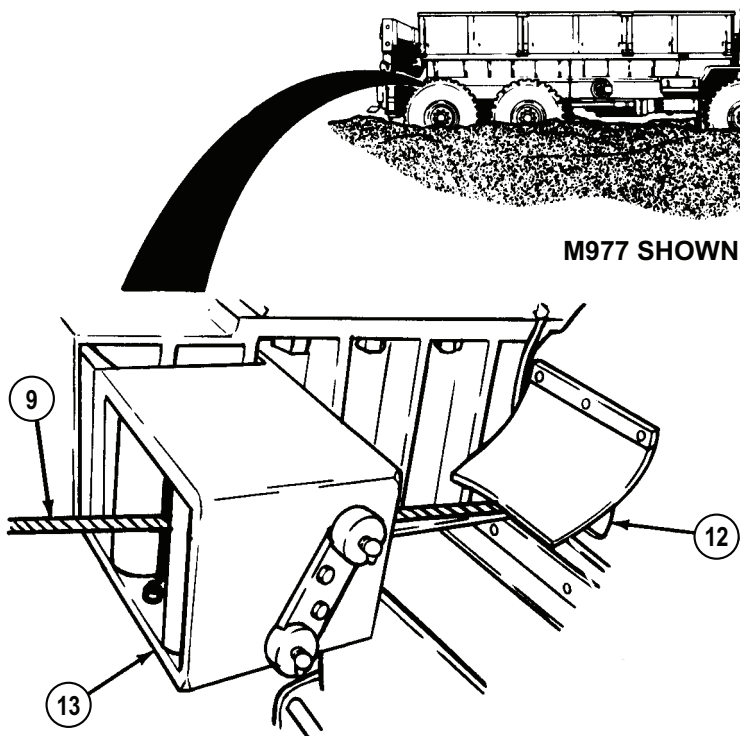
*Figure 26.*

WINCH MIRED VEHICLE TO THE REAR - Continued

15. Pay out winch cable (9) while assistant pulls cable to tree, another vehicle, or heavy object refer to FM 4-30.31. (WP 0161)
16. When winch cable (9) is let out to tree, another vehicle, heavy object, release winch shift lever (4) to center position.
17. Set PTO ENGAGE switch (2) to OFF position. Indicator light (3) will go out.

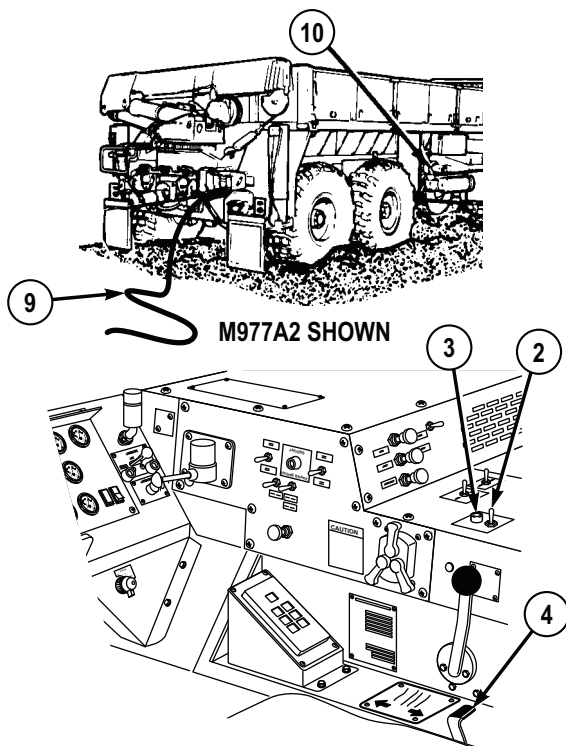

Figure 27.

18. If snatch block must be used for self-recovery operation, attach self-recovery winch cable (9) to snatch block (WP 0088) and connect end of self-recovery winch cable to mired vehicle left rear towing eye. (WP 0089) Attach snatch block to a tree, another vehicle, or heavy object refer to FM 4-30.31. (WP 0161)

CAUTION

There must be at least five wraps of cable on winch. If load is applied with less than five wraps of cable on winch, cable may come loose on drum.

WINCH MIRED VEHICLE TO THE REAR - Continued

19. Check that there are at least five wraps of winch cable (9) left on winch (10). If there are not at least five wraps of winch cable left on winch (10), stop using self-recovery winch (10) and continue with Step (46) of this procedure.

CAUTION

Do not go over winch pull capacity or winch could be damaged.

20. Ensure weight of mired vehicle and amount of winch cable (9) left on winch (10) does not go over pull capacity refer to FM 4-30.31 (WP 0161) and Self-Recovery Winch Pull Capacity table below). If pull will go over capacity, stop using self-recovery winch and continue with Step (46) of this procedure.

Table 2. Self-Recovery Winch Pull Capacity.

Cable Layer	Maximum Line Pull
1st layer (five wraps)	20,000 lbs (9 080 kg)
2nd layer	18,173 lbs (8 251 kg)
3rd layer	16,663 lbs (7 565 kg)
4th layer	15,361 lbs (6 974 kg)
5th layer	14,254 lbs (6 471 kg)

NOTE

If winch cable will be connected to another vehicle acting as a stationary anchor, refer to FM 4-30.31 (WP 0161) or Connect/Disconnect Self-Recovery Winch Cable to Another Vehicle (WP 0089) for connecting procedures.

21. If it is determined using self-recovery winch (10) will not go over winch pull capacity, connect winch cable (9) to heavy object.
22. Ensure winch shift lever (4) is at center position.
23. Set PTO ENGAGE switch (2) to OFF position. Indicator light (3) will go out.

WINCH MIRED VEHICLE TO THE REAR - Continued**WARNING**

Do not operate winch while personnel are working on or around tensioning device. Failure to comply may result in injury or death to personnel.

24. Pull back and hold tension pulley lever (14).

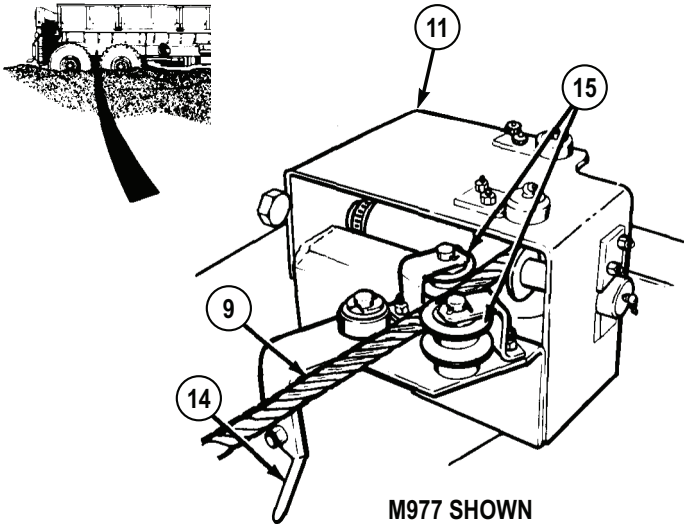

Figure 28.

25. Route winch cable (9) between pulleys (15).
 26. Release tension pulley lever (14).
 27. Ensure winch cable (9) rests inside grooves of both pulleys (15).
 28. Ensure winch cable (9) is not caught on vehicle or any other objects.
 29. Ensure all personnel are clear of winch (10) and winch cable (9).

WINCH MIRED VEHICLE TO THE REAR - Continued

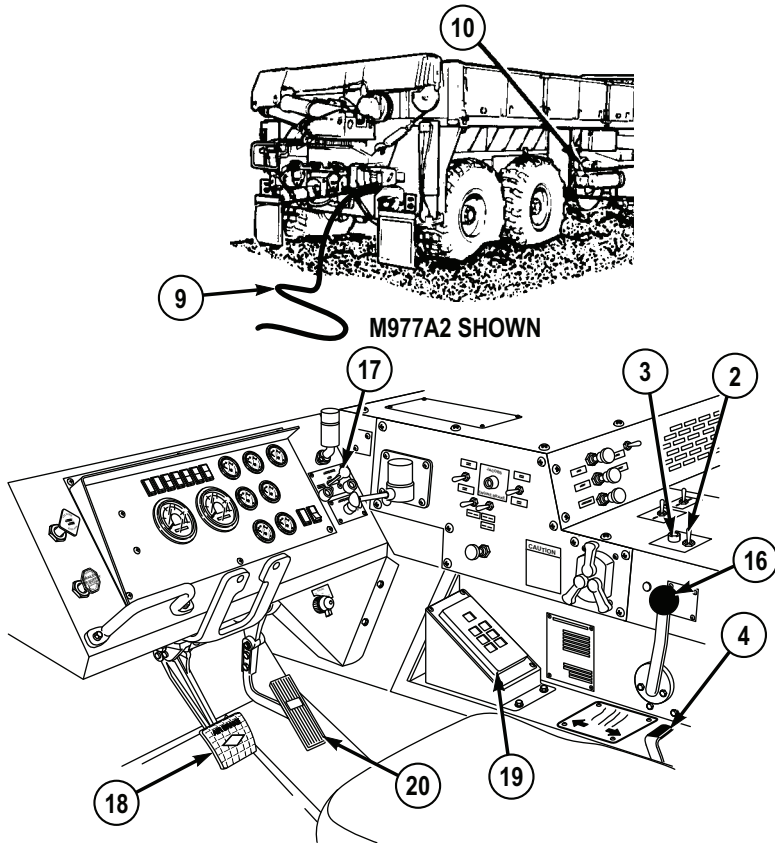

Figure 29.

30. Set PTO ENGAGE switch (2) to ON position. Indicator light (3) will illuminate.
31. Move winch shift lever (4) to IN until slack is out of winch cable (9).
32. Release winch shift lever (4) to center position.

WARNING

Keep all personnel clear of area near winch cable when tension is on cable. Failure to comply may result in injury or death to personnel.

WINCH MIRED VEHICLE TO THE REAR - Continued**CAUTION**

- Self-recovery winch is not designed to winch mired vehicle by itself. Mired vehicle drive system power must always be used with winch to self-recover vehicle, or damage to equipment can result.
- If winch does not move mired vehicle, stop using winch, overheat damage may result.

33. Ensure that TRANSFER CASE shift lever (16) is set to LO.
34. Ensure TRACTION CONTROL lever (17) is set to INTER-AXLE DIFF. LOCK.
35. Apply service brake pedal (18).
36. Set transmission range selector (19) to R (reverse).
37. Release service brake pedal (18).
38. Slightly press throttle pedal (20) and move winch shift lever (4) to IN.

NOTE

Keep winch cable tight at all times so cable does not get tangled with vehicle.

39. Adjust position of throttle pedal (20) to change engine speed as needed to keep winch cable (9) tight and mired vehicle moving.
40. When mired vehicle is on solid ground, release winch shift lever (4) to center position.
41. Park vehicle. (WP 0056)
42. Set winch shift lever (4) to OUT and pay out winch cable (9) until all tension is released.
43. When all tension is off winch cable (9), release winch shift lever (4) to center position.
44. Set PTO ENGAGE switch (2) to OFF position. Indicator light (3) will go out.

NOTE

If winch cable is connected to another vehicle, refer to Connect/ Disconnect Self-Recovery Winch Cable to Another Vehicle (WP 0089) for disconnecting procedures.

45. Disconnect winch cable (9) from heavy object.
46. If snatch block was used, disconnect end of winch cable (9) from vehicle. (WP 0089) Remove snatch block from winch cable (WP 0088) and tree, another vehicle, or heavy object refer to FM 4-30.31. (WP 0161)

WINCH MIRED VEHICLE TO THE REAR - Continued**CAUTION**

Do not reel clevis end of winch cable through roller guides. Clevis may catch on roller guide and cause cable or roller guide to break.

47. Set PTO ENGAGE switch (2) to ON position. Indicator light (3) will illuminate.
48. Set winch shift lever (4) to IN.
49. When end of cable is near rear of vehicle, release winch shift lever (4) to center position.
50. Set PTO ENGAGE switch (2) to OFF position. Indicator light (3) will go out.

WARNING

- Always wear protective gloves when handling winch cable. Never let cable run through hands. Frayed cables can cut severely. Failure to comply may result in injury or death to personnel.
 - Never operate winch with less than five wraps of cable on winch drum. Failure to comply may result in injury or death to personnel.
51. Pull clevis (7) end of winch cable (9) forward through roller guide (13) and hole (12) in fender.

WINCH MIRED VEHICLE TO THE REAR - Continued

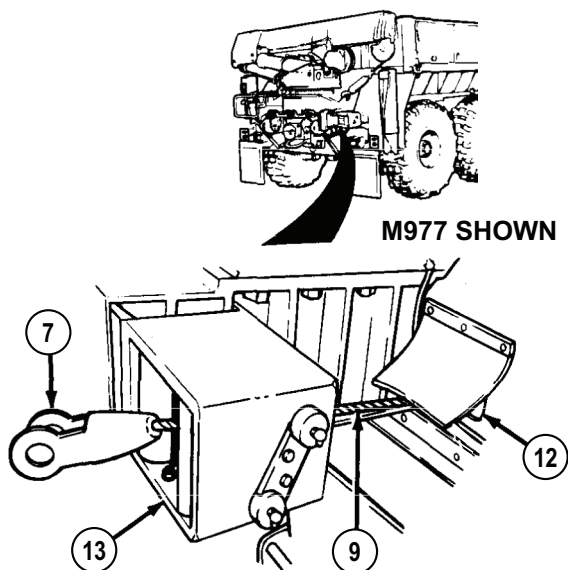

M977 SHOWN

Figure 30.

52. Pull back and hold tension pulley lever (14).

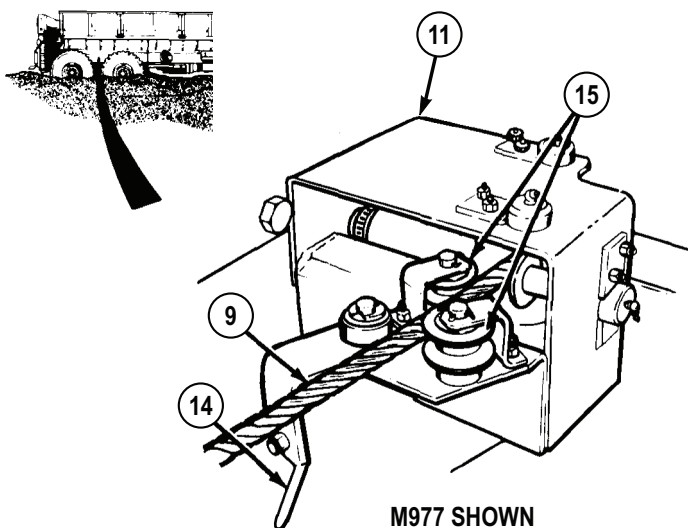

M977 SHOWN

Figure 31.

WINCH MIRED VEHICLE TO THE REAR - Continued

53. Lift winch cable (9) out of pulleys (15).
54. Release tension pulley lever (14).
55. Pull winch cable (9) forward and out of cable guide (11).
56. Set PTO ENGAGE switch (2) to ON position. Indicator light (3) will illuminate.

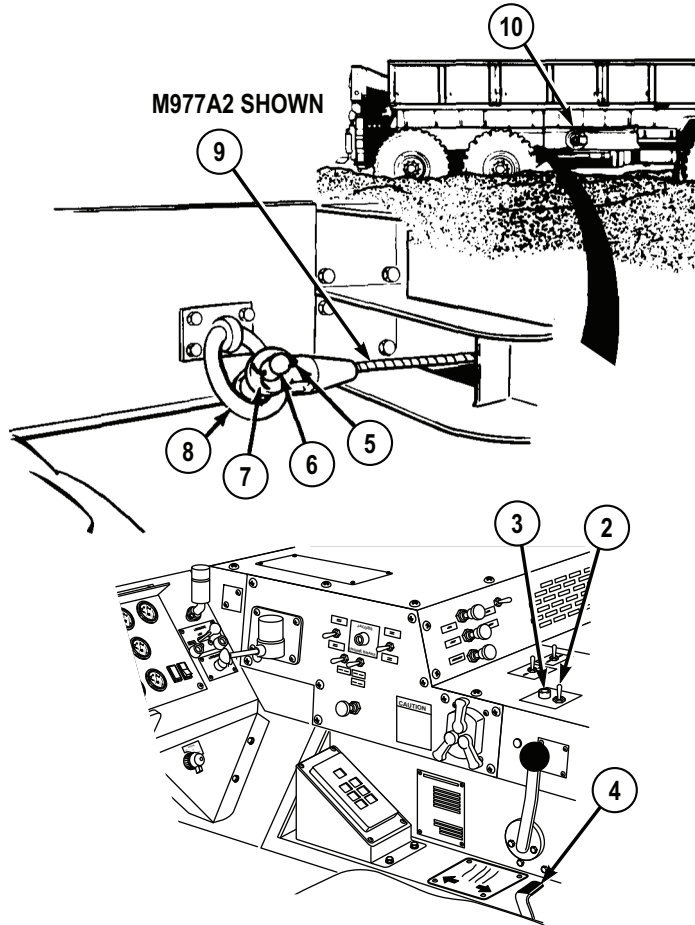

Figure 32.

57. Move winch shift lever (4) to IN position to reel in cable while assistant guides winch cable (9) to tiedown ring (8).
58. When clevis (7) is approximately 2 ft. (61 cm) from winch (10), release winch shift lever (4) to center position.

WINCH MIRED VEHICLE TO THE REAR - Continued

59. Assistant connects clevis (7) to tiedown ring (8) with pin (6) and cotter pin (5).

WARNING

Keep all personnel clear of area near winch cable when tension is on cable. Failure to comply may result in injury or death to personnel.

60. Order all personnel to stand clear of area near winch (10).

CAUTION

Do not reel in winch cable too tightly. If too much tension is applied, cable or tiedown ring can break, or winch may be damaged.

61. Once assistant and all other personnel are clear of area, move winch shift lever (4) to IN and take all slack out of winch cable (9).
62. When cable is tight, release winch shift lever (4) to center position.
63. Set PTO ENGAGE switch (2) to OFF position. Indicator light (3) will go out.
64. Shut off engine. (WP 0057)
65. Push in hydraulic selector valve control.

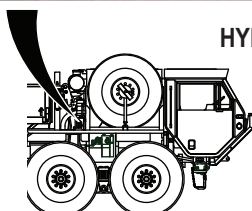
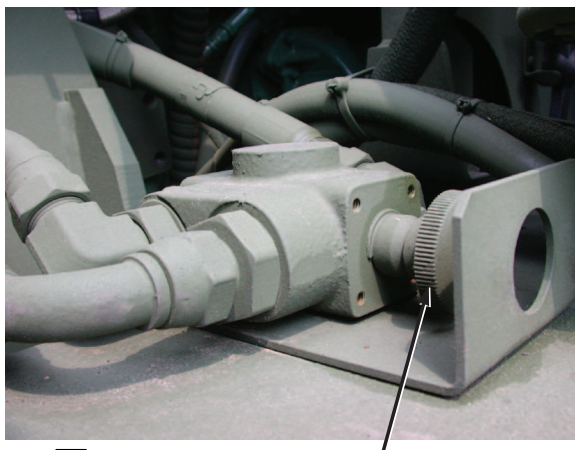
WINCH MIRED VEHICLE TO THE REAR - Continued

**HYDRAULIC SELECTOR
VALVE CONTROL**

Figure 33.

66. Adjust mirror (1) for driving.

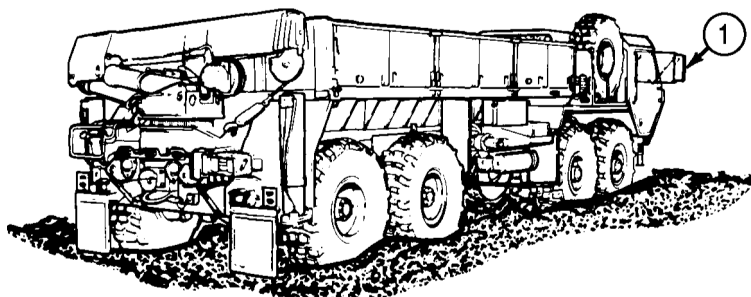

Figure 34.

END OF TASK

END OF WORK PACKAGE

OPERATOR MAINTENANCE SNATCH BLOCK INSTALLATION/REMOVAL

INITIAL SETUP:

Not Applicable

ATTACH SNATCH BLOCK TO SELF-RECOVERY WINCH CABLE

1. Remove snatch block (1) from stowage.

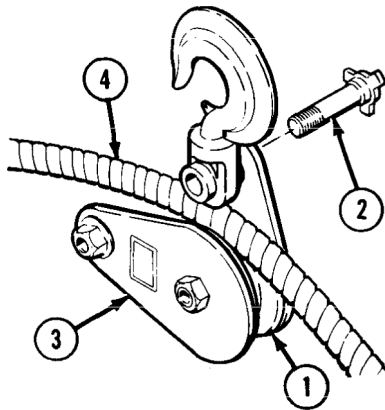

Figure 1.

2. Remove screw (2).
3. Move plate (3) to side to open snatch block (1).
4. Place winch cable (4) in snatch block (1).
5. Close plate (3) and align holes.
6. Install screw (2).
7. Ensure screw (2) is tight and winch cable (4) can be moved freely through snatch block (1).
8. Continue with self-recovery operation (WP 0087).

REMOVE SNATCH BLOCK FROM SELF-RECOVERY WINCH CABLE

1. Check that there is enough slack in winch cable (1).

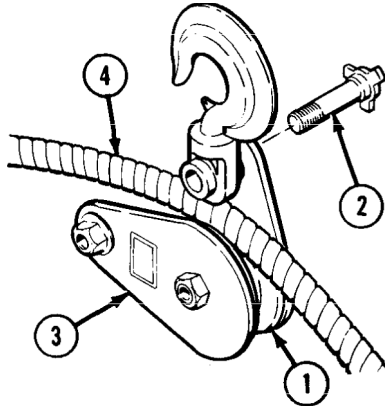

Figure 2.

2. Remove screw (2).
3. Move plate (3) to side to open snatch block (4).
4. Take winch cable (1) out of snatch block (4).
5. Close plate (3) and align holes.
6. Install screw (2).
7. Stow snatch block (4) in stowage box.
8. Continue with self-recovery operation (WP 0087).

END OF TASK

END OF WORK PACKAGE

OPERATOR MAINTENANCE
CONNECT/DISCONNECT SELF-RECOVERY WINCH CABLE TO ANOTHER VEHICLE

INITIAL SETUP:

Not Applicable

CONNECT CABLE TO VEHICLE

CAUTION

When attaching self-recovery winch cable to another vehicle, that vehicle must be used only as an anchor point or damage to equipment can result.

NOTE

There are three tiedown rings on each side of vehicle.

1. Unscrew one tiedown ring (1) from mounting plate (2).

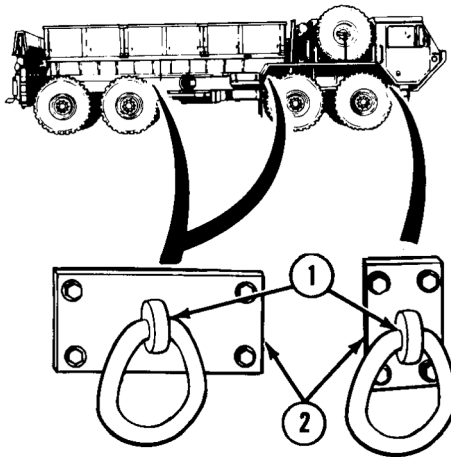
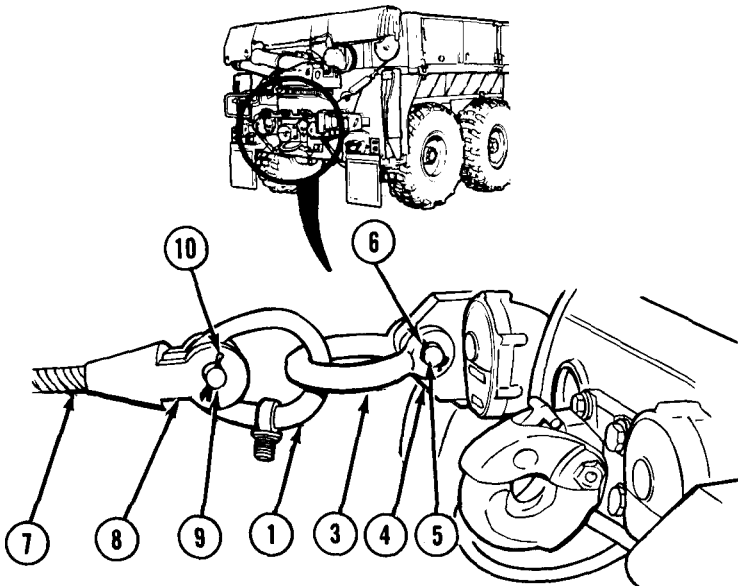

Figure 1.

2. Remove lifting shackle (3) from stowage.

CONNECT CABLE TO VEHICLE - Continued*Figure 2.*

3. Insert lifting shackle (3) through tiedown ring (1).
4. Connect lifting shackle (3) to left front of left rear tow eye (4) with pin (5).
5. Install cotter pin (6).
6. Connect self-recovery winch cable (7) with clevis (8) to tiedown ring (1) with pin (9).
7. Install cotter pin (10).
8. Continue with self-recovery winch operation. (WP 0087)

DISCONNECT CABLE FROM VEHICLE

1. Ensure there is enough slack in winch cable (1).

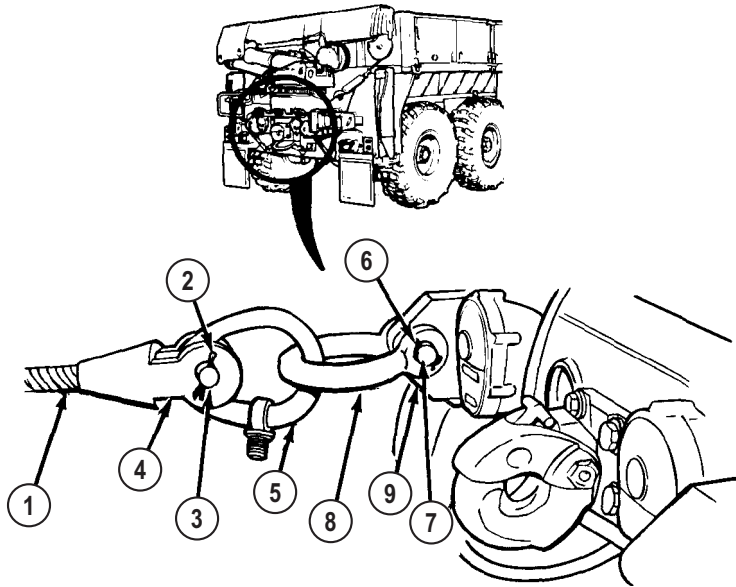
DISCONNECT CABLE FROM VEHICLE - Continued*Figure 3.*

2. Remove cotter pin (2).
3. Remove pin (3) and disconnect clevis (4) from tiedown ring (5).
4. Remove cotter pin (6).
5. Remove pin (7) and disconnect lifting shackle (8) from tow eye (9).
6. Remove tiedown ring (5) from lifting shackle (8).
7. Stow lifting shackle (8).

NOTE

There are three tiedown rings on each side of vehicle.

8. Install tiedown ring (5) into mounting plate (10).

DISCONNECT CABLE FROM VEHICLE - Continued

Figure 4.

9. Continue with self-recovery winch operation. (WP 0087)

END OF TASK

END OF WORK PACKAGE

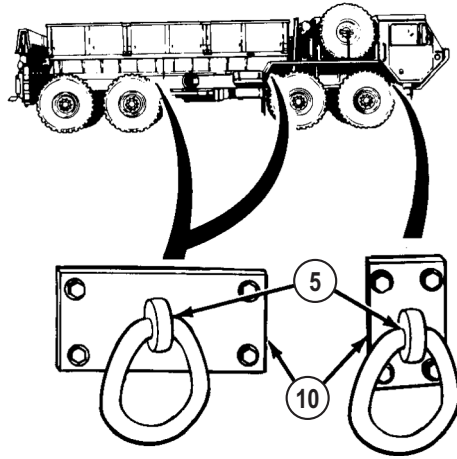
**OPERATOR MAINTENANCE
TOW DISABLED VEHICLE**

INITIAL SETUP:

Not Applicable

TOW DISABLED VEHICLE**CAUTION**

- When towing another vehicle, do not go over GCWR given in equipment data (WP 0006). Failure to comply may result in damage to equipment.
- Propeller shaft must be removed by field level maintenance before towing disabled vehicle or equipment may be damaged.

NOTE

Disabled vehicles must be prepared and moved in accordance with FM 21-305 . If instructed to do so, manually release spring brakes (WP 0101) as part of preparing disabled vehicle for towing.

1. Install and operate portable beacon lights. (WP 0074)
2. Set TRANSFER CASE shift lever (1) to NEUT (neutral) position.
3. Set TRACTION CONTROL lever (2) to OFF.

TOW DISABLED VEHICLE - Continued

Figure 1.

4. Push in PARKING BRAKE control on disabled vehicle (refer to operator's manual).
5. Push in TRAILER AIR SUPPLY control (4) on recovery vehicle.
6. Transport disabled vehicle.

END OF TASK

END OF WORK PACKAGE

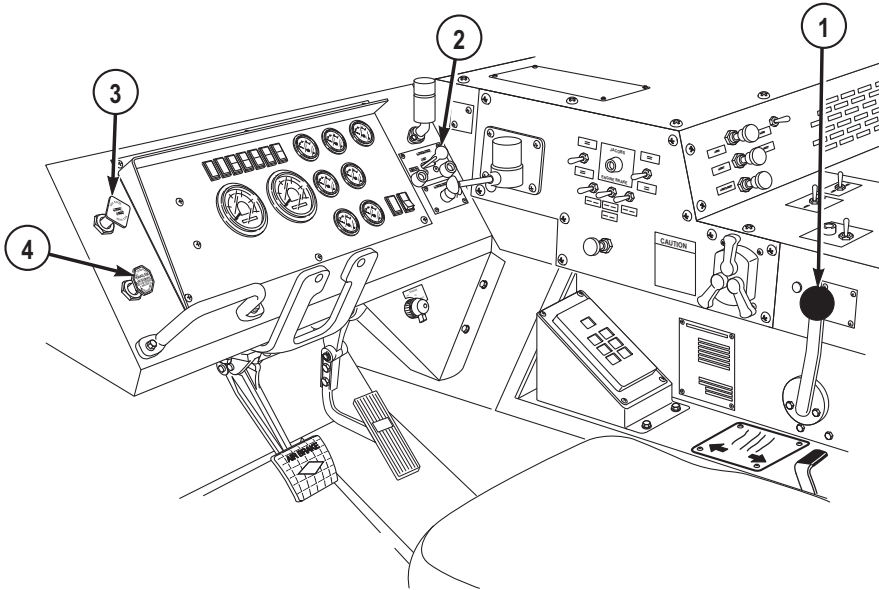
OPERATOR MAINTENANCE CONNECT/DISCONNECT TOW BAR

INITIAL SETUP:

Personnel Required

Operator and Assistant(s) - - - (3)

CONNECT TOW BAR

WARNING



Do not use 10-ton tow bar with self-guided coupler (normally found on some M1120 LHS and M1977 CBT models). Self-guided coupler is not compatible with 10-ton tow bar. Failure to comply may result in injury or death to personnel

WARNING



Tow bar is heavy. Do not attempt to lift or move tow bar without the aid of two assistants and a lifting device. Failure to comply may result in injury or death to personnel.

NOTE

- This procedure is a three soldier task.
 - The 10-ton tow bar should always be used in conjunction with two 16 ft. (5 m) safety chains.
 - Allow ample distance between towing vehicle and disabled vehicle to connect 10-ton tow bar.
1. Align rear of towing vehicle near front of disabled vehicle.

CONNECT TOW BAR - Continued**WARNING**

Tow bar is heavy. Do not attempt to lift or move tow bar without the aid of two assistants and a lifting device. Failure to comply may result in injury or death to personnel.

2. With aid of two assistants and a lifting device, remove tow bar (1) from stowage.

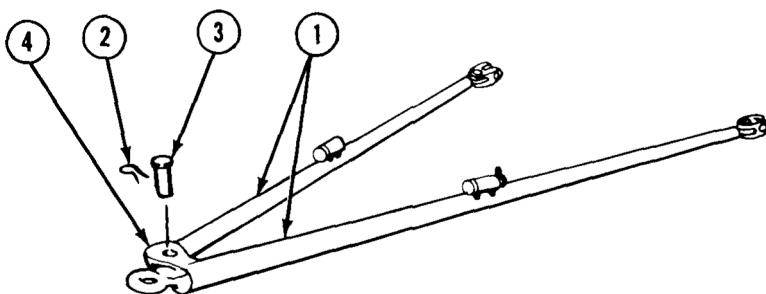

Figure 1.

3. Remove cotter hairpin (2) and pin (3) from tow bar (1).
4. Separate tow bar (1) at pivot point (4).

NOTE

Towing eyes on all models of HEMTT series vehicles are same in appearance, operation, and location. HEMTT M977 shown.

5. Position legs of tow bar (1) in front of disabled vehicle with spare pins (5) facing up.

CONNECT TOW BAR - Continued

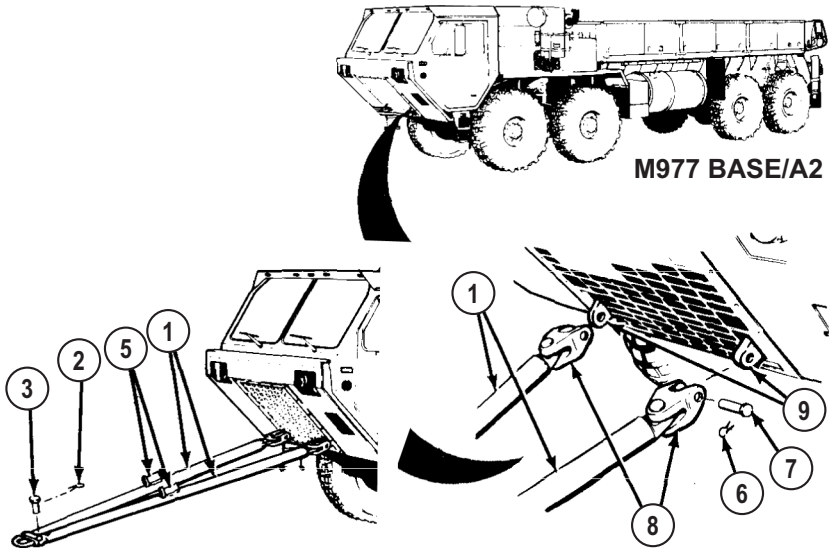

Figure 2.

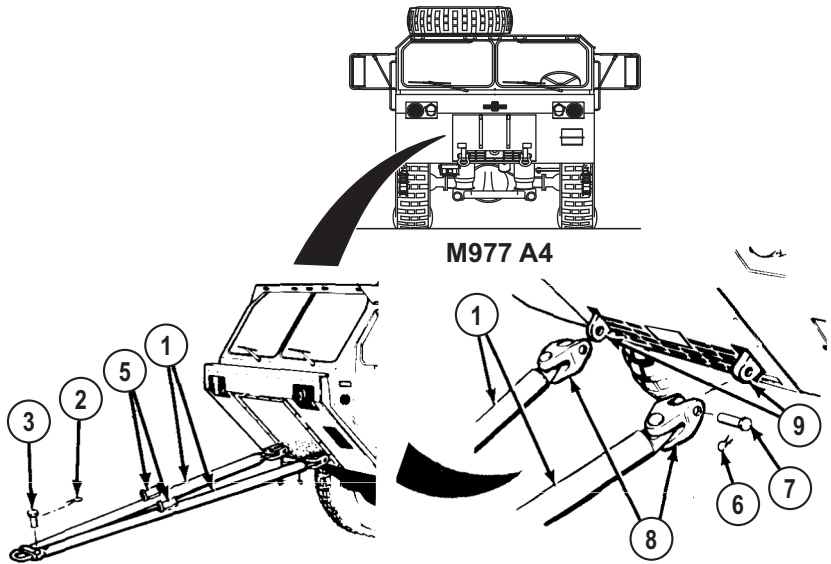

Figure 3.

6. Remove two cotter hairpins (6) and pins (7) from tow bar shackles (8).

CONNECT TOW BAR - Continued**WARNING**

Tow bar is heavy. Do not attempt to lift or move tow bar without the aid of two assistants and a lifting device. Failure to comply may result in injury or death to personnel.

7. While two assistants hold one leg of tow bar (1) and align shackle (8) with towing eye (9), install pin (7) and cotter hairpin (6).
8. Repeat Step (7) for other leg of tow bar (1).
9. Align legs of tow bar (1) at pivot point (4) and install pin (3) and cotter hairpin (2).

WARNING

Do not use 10-ton tow bar with self-guided coupler (normally found on some M1120 LHS and M1977 CBT models). Self-guided coupler is not compatible with 10-ton tow bar. Failure to comply may result in injury or death to personnel

NOTE

Pintle hook on all models of HEMTT series vehicles are same in appearance, operation, and location. HEMTT M977 shown.

10. Position the towing vehicle so pintle hook is aligned with tow bar lunette eye.
11. Remove cotter pin (10) from pintle hook (11).

CONNECT TOW BAR - Continued

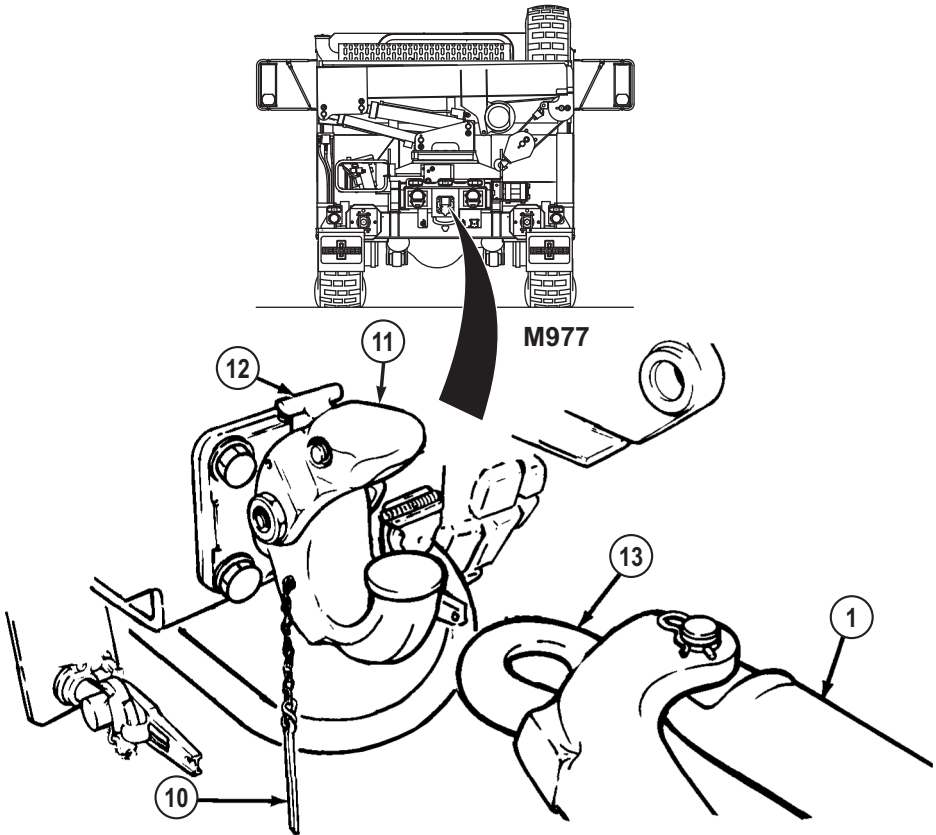

Figure 4.

12. Pull latch (12) away from vehicle and hold.
13. Lift top of pintle hook (11) and let go of latch (12). Pintle hook (11) will be locked open.

WARNING

Tow bar is heavy. Do not attempt to lift or move tow bar without the aid of two assistants and a lifting device. Failure to comply may result in injury or death to personnel.

CONNECT TOW BAR - Continued**WARNING**

Do not put hands near pintle hook while aligning lunette eye with pintle hook. Failure to comply may result in injury or death to personnel.

14. While two assistants lift tow bar (1), slowly back up towing vehicle until tow bar lunette eye (13) connects to pintle hook (11).
15. Pull latch (12) and close top half of pintle hook (11).
16. Install cotter pin (10) in pintle hook (11).

NOTE

If air system of disabled vehicle is damaged, manually release spring brakes (WP 0101) and skip to Step (20).

17. Remove two inter-vehicular air lines (14) from stowage.

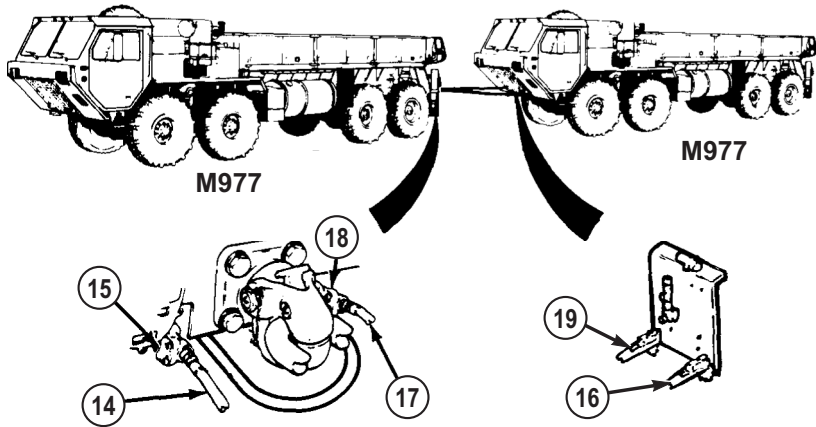
CONNECT TOW BAR - Continued*Figure 5.***NOTE**

Gladhands on all models of HEMTT series vehicles are same in appearance, operation, and location. HEMTT M977 shown.

18. Connect first intervehicular air line (14) to driver side rear gladhand (15) of towing vehicle and driver side front gladhand (16) of disabled vehicle.
19. Connect second intervehicular air line (17) to passenger side rear gladhand (18) of towing vehicle and passenger side front gladhand (19) of disabled vehicle.
20. Remove two 16 ft. (5 m) safety chains (20) from stowage.

NOTE

- Both driver side and passenger side walking beams are same. Driver side shown.
- If disabled vehicle is either a BASE or A2 model HEMTT series vehicle (refer to data plate on inside of drivers door), complete Step

CONNECT TOW BAR - Continued

(21). If disabled vehicle is an A4 model HEMTT series vehicle (refer to data plate on inside of drivers door), skip to Step (22).

21. Route one 16 ft. (5 m) safety chain (20) over walking beam (21) behind No. 1 axle (22) on disabled vehicle, and hook 16 ft. (5 m) safety chain (20) back into itself under walking beam (21) as shown.

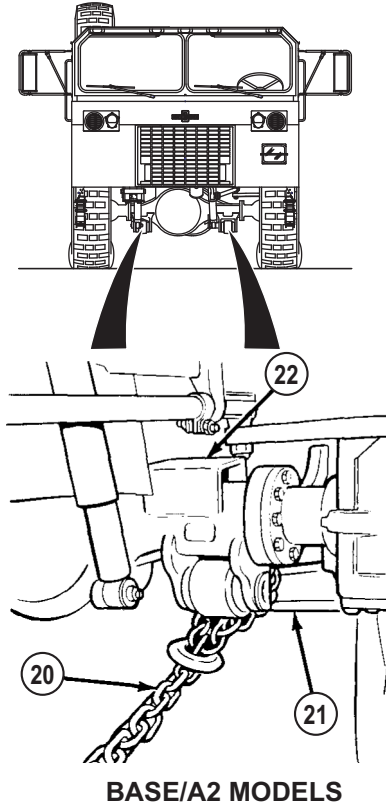

Figure 6.

CAUTION

Special care should be taken when connecting 16 ft. (5 m) safety chain to tiedown ring. The procedure listed below routes the 16 ft. (5 m) safety chain in such a way as to minimize excessive contact with vehicle air suspension air springs during towing. Failure to comply may result in damage to equipment.

CONNECT TOW BAR - Continued**NOTE**

Both driver side and passenger side tiedown rings are same. Driver side shown.

22. Connect 16 ft. (5 m) safety chain (20) to disabled vehicle tiedown ring (23):
 - a. Route end (without safety shackle) of 16 ft. (5 m) safety chain (20) through tiedown ring (23) from inboard to outboard until grab hook (24) hangs just below bottom of air spring (25).

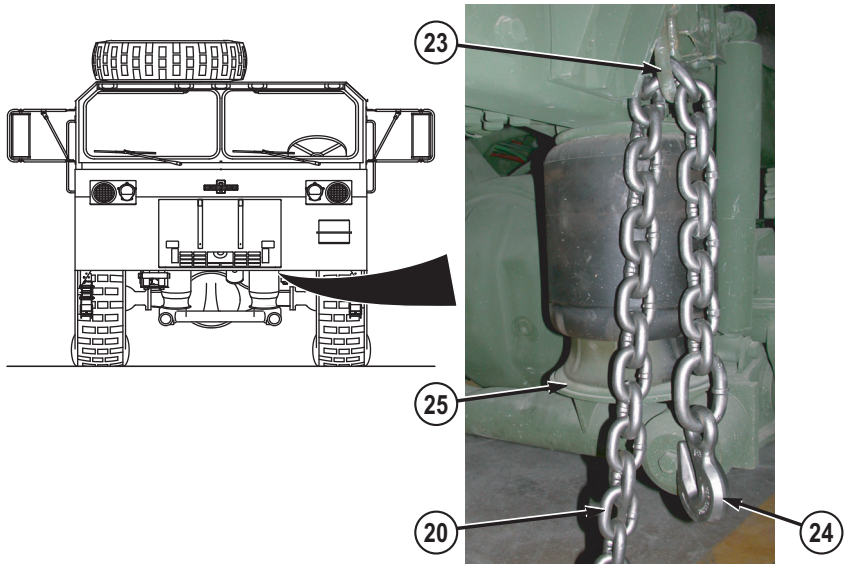

Figure 7.

- b. Hook 16 ft. (5 m) safety chain (20) back to itself. Grab hook (24) should open towards ground (shown) when tension is applied to 16 ft. (5 m) safety chain (20).

CONNECT TOW BAR - Continued

Figure 8.

23. Repeat Steps (21) or (22) for other side of disabled vehicle.

NOTE

- 16 ft. (5 m) safety chain may be attached to either safety chain loop or towing shackles.
 - 16 ft. (5 m) safety chain should be attached so they are just above, but not in contact with the ground.
24. Route free ends of two 16 ft. (5 m) safety chain (20) through safety chain loop (26) on towing vehicle and attach each 16 ft. (5 m) safety chain (20) back into itself as shown.

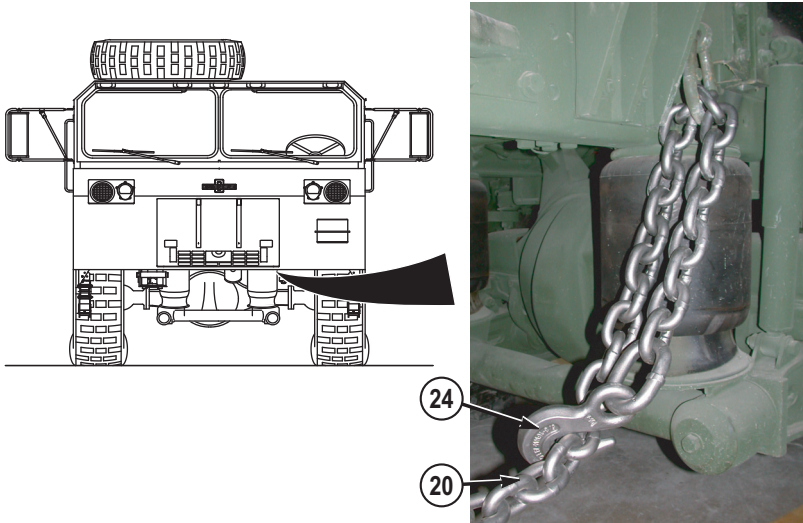
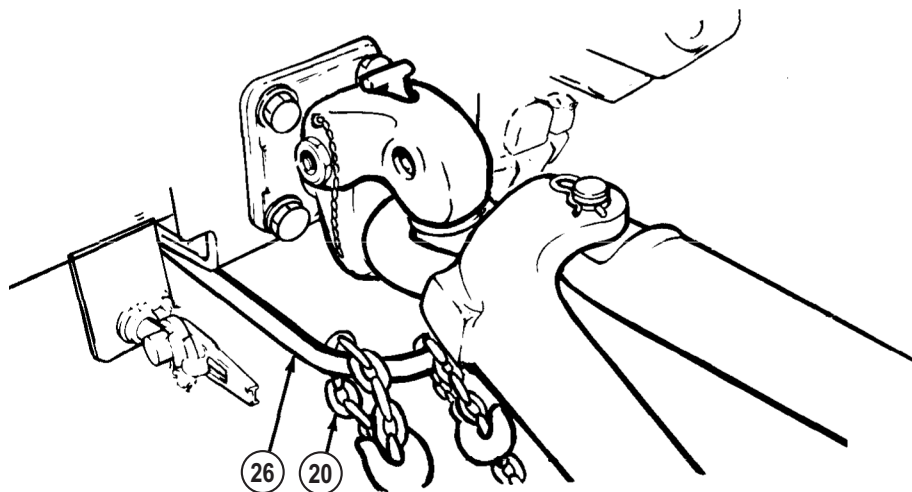
CONNECT TOW BAR - Continued*Figure 9.*

25. Tow disabled vehicle. (WP 0090)

DISCONNECT TOW BAR**NOTE**

- This procedure is a three soldier task.
- Vehicle should be parked and disconnected on level ground.

1. Park towing vehicle. (WP 0056)
2. Pull out TRAILER AIR SUPPLY control (1) on towing vehicle.

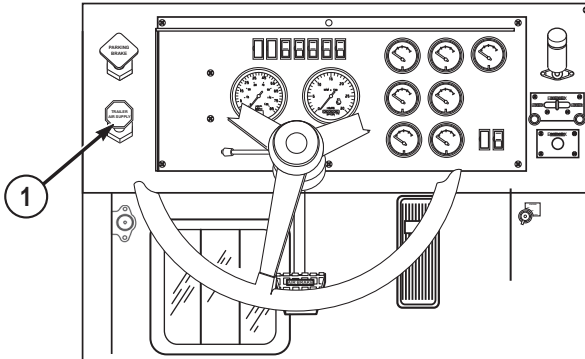
DISCONNECT TOW BAR - Continued*Figure 10.***NOTE**

If disabled vehicle parking brake is inoperable and/or spring brakes on disabled vehicle were manually released, install wheel chocks (refer to operator's manual).

3. Engage parking brake on disabled vehicle (refer to operator's manual).
4. Disconnect two 16 ft. (5 m) safety chains (2) from towing vehicle and disabled vehicle. Return 16 ft. (5 m) safety chains (2) to stowage.

DISCONNECT TOW BAR - Continued

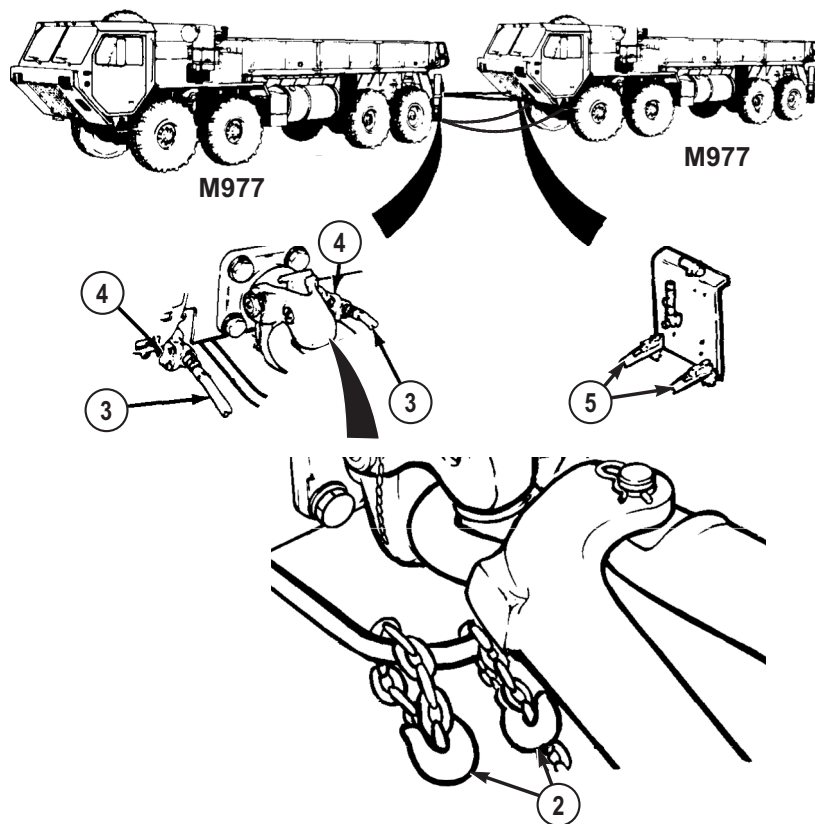
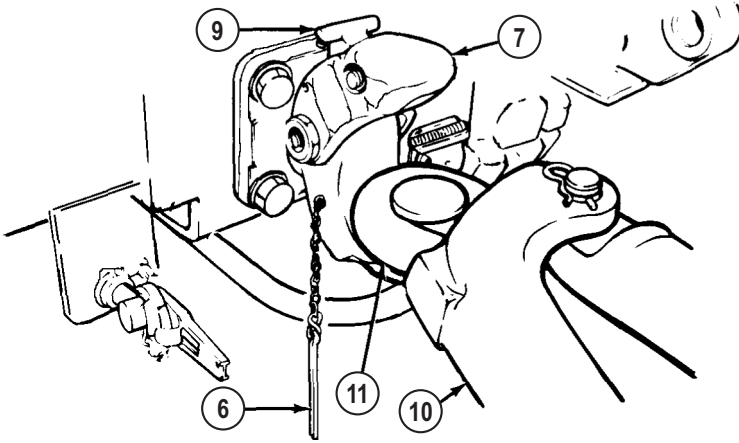

Figure 11.

NOTE

If spring brakes on disabled vehicle were manually released before towing, skip to Step (6).

5. Disconnect two intervehicular air lines (3) from towing vehicle rear gladhands (4) and from disabled vehicle front gladhands (5). Return intervehicular air lines (5) to stowage.
6. Remove cotter pin (6) from towing vehicle pintle hook (7).

DISCONNECT TOW BAR - Continued*Figure 12.*

7. Pull latch (9) away from vehicle and hold.
8. Lift top of pintle hook (7) and let go of latch (9). Pintle hook (7) will be locked open.
9. As two assistants lift tow bar (10) until lunette eye (11) is clear of pintle hook (10), drive towing vehicle forward approximately 15 ft. (4.6 m).
10. As assistants lower tow bar (10) to the ground, park towing vehicle.
11. Pull latch (9) to close towing vehicle pintle hook (7) and install cotter pin (6) in pintle hook (7).
12. Remove cotter hairpin (12) and pin (13) and separate tow bar (10) at pivot point (14).

DISCONNECT TOW BAR - Continued

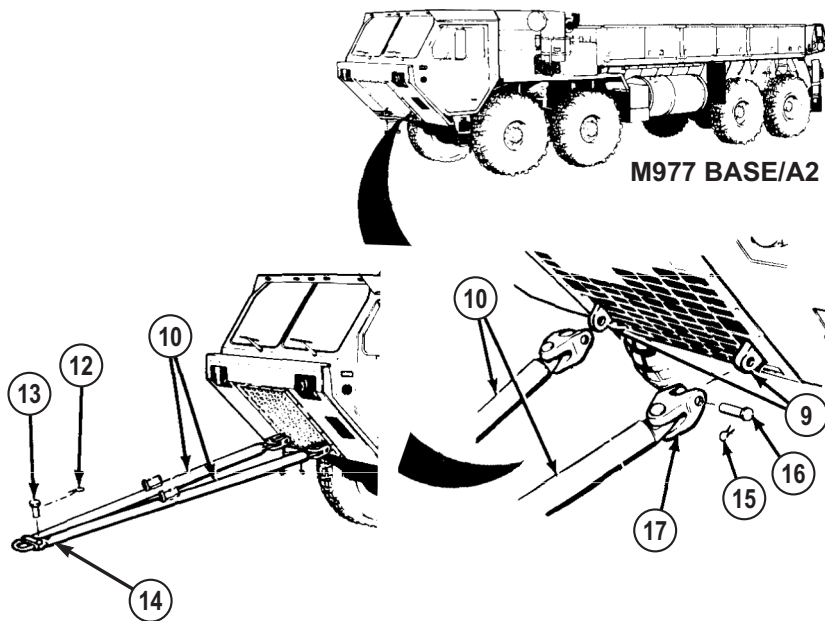

Figure 13.

DISCONNECT TOW BAR - Continued

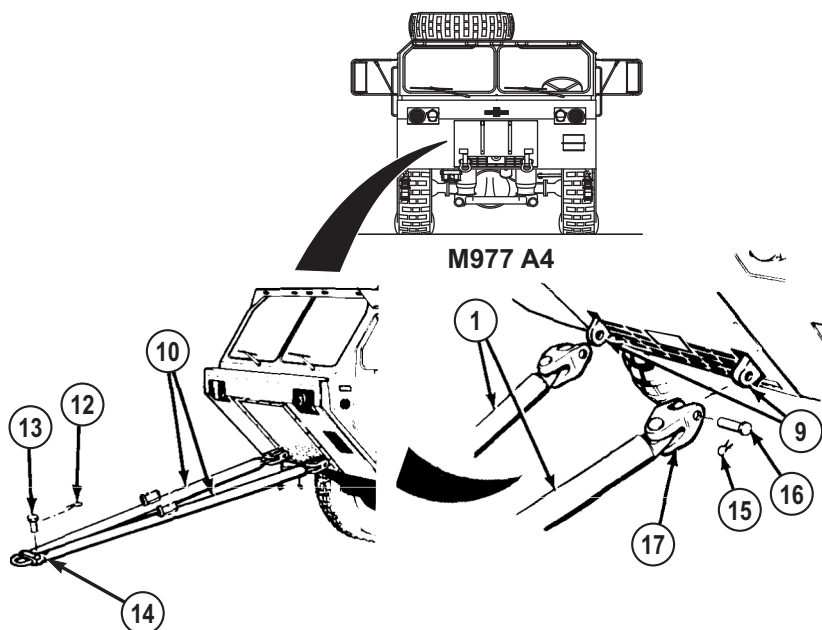

Figure 14.

13. With aid of an assistant, hold one leg of tow bar (10) while another assistant removes cotter hairpin (15) and pin (16) from shackle (17).
14. Repeat Step (13) for other leg of tow bar (10).
15. With aid of two assistants, lower tow bar (10) to the ground.
16. Install two pins (16) and cotter hairpins (15) in shackles (17).
17. Align legs of tow bar (10) at pivot point (14) and install pin (13) and cotter hairpin (12).

WARNING

Tow bar is heavy. Do not attempt to lift or move tow bar without the aid of two assistants and a lifting device. Failure to comply may result in injury or death to personnel.

DISCONNECT TOW BAR - Continued

18. With aid of two assistants and lifting device, return tow bar (10) to stowage.

END OF TASK

END OF WORK PACKAGE

OPERATOR MAINTENANCE OPERATE VEHICLE IN EXTREME HEAT

INITIAL SETUP:

Not Applicable

EXTREME HEAT OPERATION

CAUTION

- When operating vehicle in very hot temperatures of above 100°F (38°C), extra care must be taken to prevent overheating engine (temperatures over 230°F (110°C) and transmission (temperatures over 250°F, 121°C). Watch water and transmission temperature gauges closely. Failure to comply may result in damage to equipment.
- Check oil levels often and keep operating strain as low as possible. Vehicle cooling and lubrication systems support each other. Failure of one system will rapidly cause failure of other systems.

NOTE

- Close heater valves to improve the efficiency of cabin air conditioning kit.
 - Closing the heater valves disables cabin heat.
1. Keep operating temperatures as low as possible:
 - a. Set transmission range selector (1) to N (neutral) while engine is running and not required to move.
 - b. Use low gear ranges only when necessary.
 - c. Stop vehicle for cooling off periods, and idle engine as often as possible. Let engine idle for approximately 3 minutes before shutting down. Idling will cool engine faster than quick shutdown and may prevent damage from remaining engine heat.
 - d. Check oil levels often. Oil seals are more likely to leak in extreme hot weather.
 - e. Check air filter restriction indicator (2) frequently. If indicator shows red:
 - (1) Park vehicle. (WP 0056)

EXTREME HEAT OPERATION - Continued

- (2) Shut off engine. (WP 0057)
- (3) Notify field level maintenance.

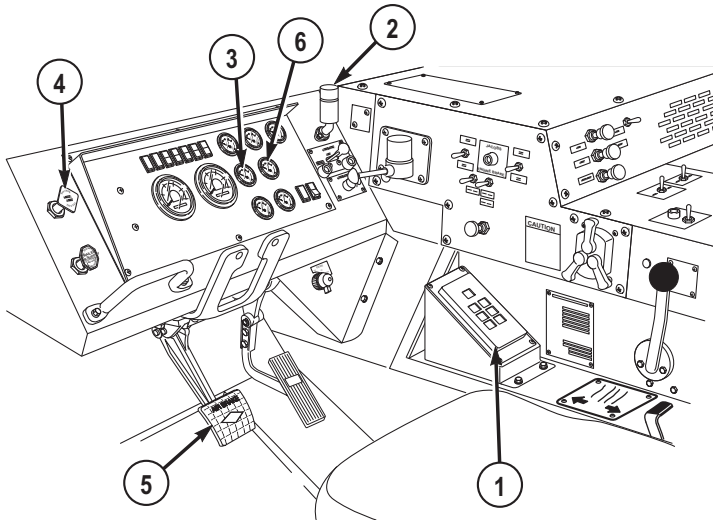

Figure 1.

2. If TRANS TEMP gauge (3) reads 250°F (121°C) or above, perform the following steps:
 - a. Slow vehicle.
 - b. Set transmission range selector (1) to next lower gear range.
 - c. Continue operation.
 - d. When TRANS TEMP gauge (3) reads normal range:
 - (1) Set transmission range selector (1) to normal gear range.
 - (2) Continue operation.
 - e. If TRANS TEMP gauge (3) does not return to normal range:
 - (1) Stop vehicle.
 - (2) Set transmission range selector (1) to N (neutral).

NOTE

Dashboard parking brake indicator will illuminate when PARKING BRAKE control is applied.

- (3) Pull out PARKING BRAKE control (4).

EXTREME HEAT OPERATION - Continued

- (4) Allow transmission to cool.
- f. When TRANS TEMP gauge (3) reads normal range:
 - (1) Apply service brake pedal (5).

NOTE

Dashboard parking brake indicator will go out when PARKING BRAKE control is released.

- (2) Push in PARKING BRAKE control (4).
 - (3) Set transmission range selector (1) to normal gear range.
 - (4) Continue operation.
3. If WATER TEMP gauge (6) indicates coolant temperature is near overheating, perform the following steps:
- a. Slow vehicle.
 - b. Set transmission range selector (1) to next lower gear range.
 - c. Continue operation.
 - d. When WATER TEMP gauge (6) reads normal range:
 - (1) Set transmission range selector (1) to normal gear range.
 - (2) Continue operation.
 - e. If WATER TEMP gauge (6) does not return to normal range:
 - (1) Stop vehicle.
 - (2) Set transmission range selector (1) to N (neutral).

NOTE

Dashboard parking brake indicator will illuminate when PARKING BRAKE control is applied.

- (3) Pull out PARKING BRAKE control (4).
- (4) Allow engine to cool.
- f. When WATER TEMP gauge (6) reads normal range:
 - (1) Apply service brake pedal (5).

NOTE

Dashboard parking brake indicator will go out when PARKING BRAKE control is released.

EXTREME HEAT OPERATION - Continued

- (2) Push in PARKING BRAKE control (4).
 - (3) Set transmission range selector (1) to normal gear range.
 - (4) Continue operation.
4. Check cooling system often and notify field level maintenance if any of the following are found:
- a. Low coolant level in radiator.
 - b. Leaking hose connections which have been tightened but still leak.
 - c. Cracked or leaking hoses.
 - d. Radiator or charge air cooler fins/grill plugged with mud, debris, etc.

NOTE

- Batteries do not hold charge well in extreme heat.
 - Battery will be tagged (white circle printed on top) for use in extreme heat conditions as specific gravity must be changed to adjust for heat (refer to TM 9-6140-200-14).
5. Keep batteries full, but do not overfill. Check battery electrolyte daily.
6. In hot, damp climates check body and chassis often and notify field level maintenance if any of the following are found:
- a. Signs of pitting or paint blistering on metal surfaces.
 - b. Signs of mildew, mold, or fungus on fabrics and rubber.
7. Adjust lubrication intervals as specified in applicable lubrication instructions (refer to PMCS).
8. Park vehicle (WP 0056) in sheltered area, out of wind if possible. If no shelter is available, park so vehicle does not face into wind.

END OF TASK**END OF WORK PACKAGE**

OPERATOR MAINTENANCE OPERATION IN EXTREME DUST

INITIAL SETUP:

Not Applicable

OPERATE VEHICLE IN EXTREME DUST

CAUTION

Clouds of dust can scratch glass surfaces. Keep glass surfaces covered as much as possible in these conditions to prevent scratching.

1. Leave glass surfaces covered if not needed for operations. Take extra care when cleaning glass to prevent scratching surfaces.
2. Keep close watch on air filter restriction indicator (1) located on top right side of driver's instrument panel.

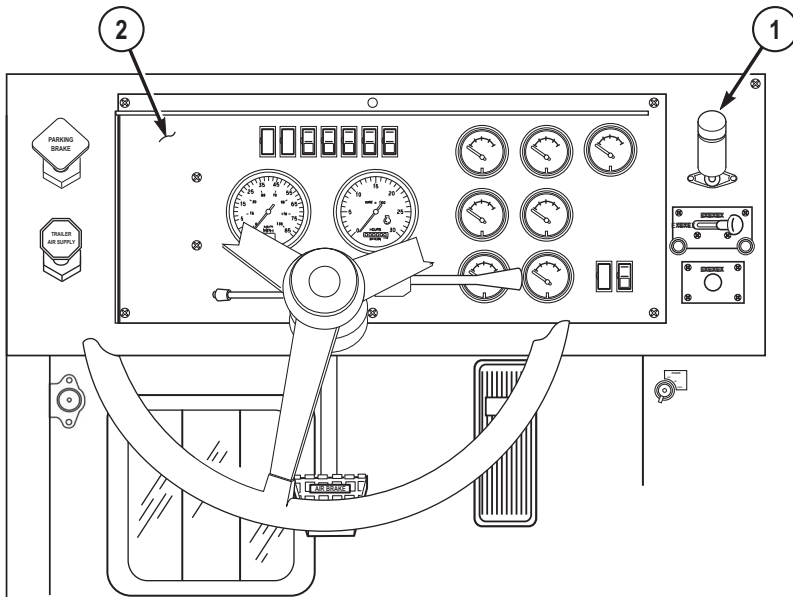

Figure 1.

OPERATE VEHICLE IN EXTREME DUST - Continued

3. Continuously scan gauges and indicators on driver's instrument panel (2) to be sure dust does not affect equipment.
4. Allow as much distance as possible between vehicles and operate at low speeds.
5. At stops, check and drain fuel/water separator (3).

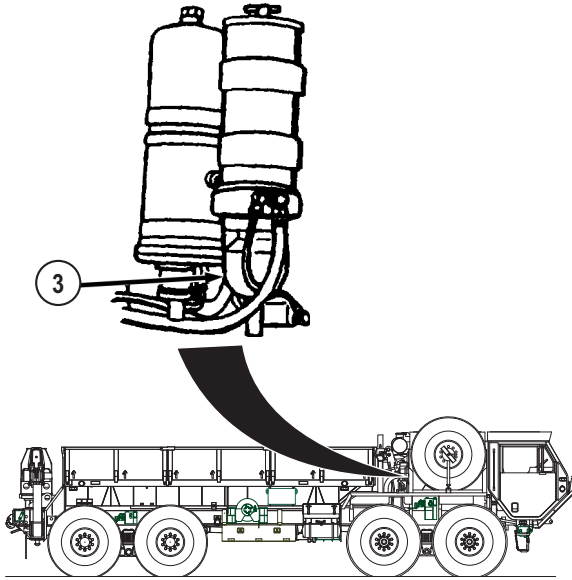

Figure 2.

6. When possible, park vehicle so it does not face into wind.

OPERATE GROVE CRANE IN EXTREME DUST**NOTE**

Lubricate outrigger bottom plate, boom wear pads, and exposed rotation gears often when cranes are operating in dusty environment (refer to PMCS - Semiannual procedures (WP 0149) for more information).

1. When operating the grove crane in a blowing dust environment, perform the following:
 - a. Check gear teeth of rotation gear bearing and pinion for an accumulation of dust within the lubricant.

OPERATE GROVE CRANE IN EXTREME DUST - Continued

Figure 3.

- b. If level of dust prevents rotation of crane, notify field level maintenance and have lubricant removed.
- c. If necessary, notify field level maintenance to apply a light coating of wax to gear teeth for rust prevention.
- d. Refer to appropriate PMCS for proper lubrication of gear teeth when returning to normal operating conditions.

END OF TASK

END OF WORK PACKAGE

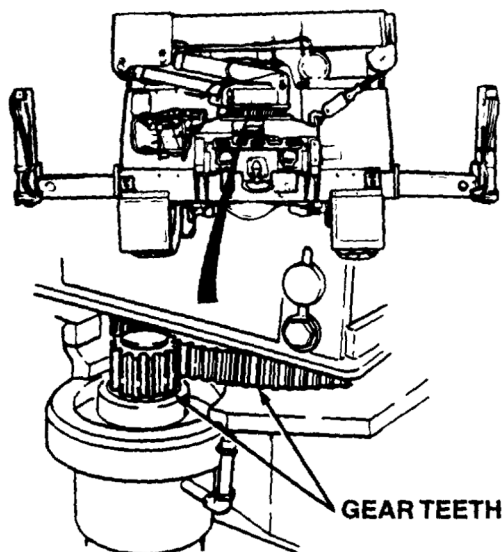
**OPERATOR MAINTENANCE
OPERATE VEHICLE IN SAND OR MUD**

INITIAL SETUP:

Not Applicable

OPERATE VEHICLE IN SAND OR MUD

CAUTION

Blowing sand may scratch glass surfaces. Glass surfaces should remain covered as much as possible in these conditions to prevent scratching.

NOTE

Operating in mud can worsen vehicle braking and speed up brake wear. If braking worsens while operating in mud, dry brakes by driving vehicle approximately 500 ft. (153 m) with service brakes frequently applied. This must be done with brake drums totally out of mud, so that drying action can take place. If adequate braking is not restored by drying brakes, notify field level maintenance.

1. Leave glass surfaces covered if not needed for operations. Extra care should be taken when cleaning glass surfaces to prevent scratching surfaces.

NOTE

Principles of driving in sand can also be applied to driving in mud. Best time to drive on sand is at night or early morning when sand is damp. Damp sand gives better traction.

- a. Check air filter restriction indicator (1) often.
2. Adjust tires to correct tire pressure for type tire and environment. (WP 0006)
3. Set TRANSFER CASE shift lever (2) to LO. 8X8 DRIVE indicator (3) will illuminate.

OPERATE VEHICLE IN SAND OR MUD - Continued

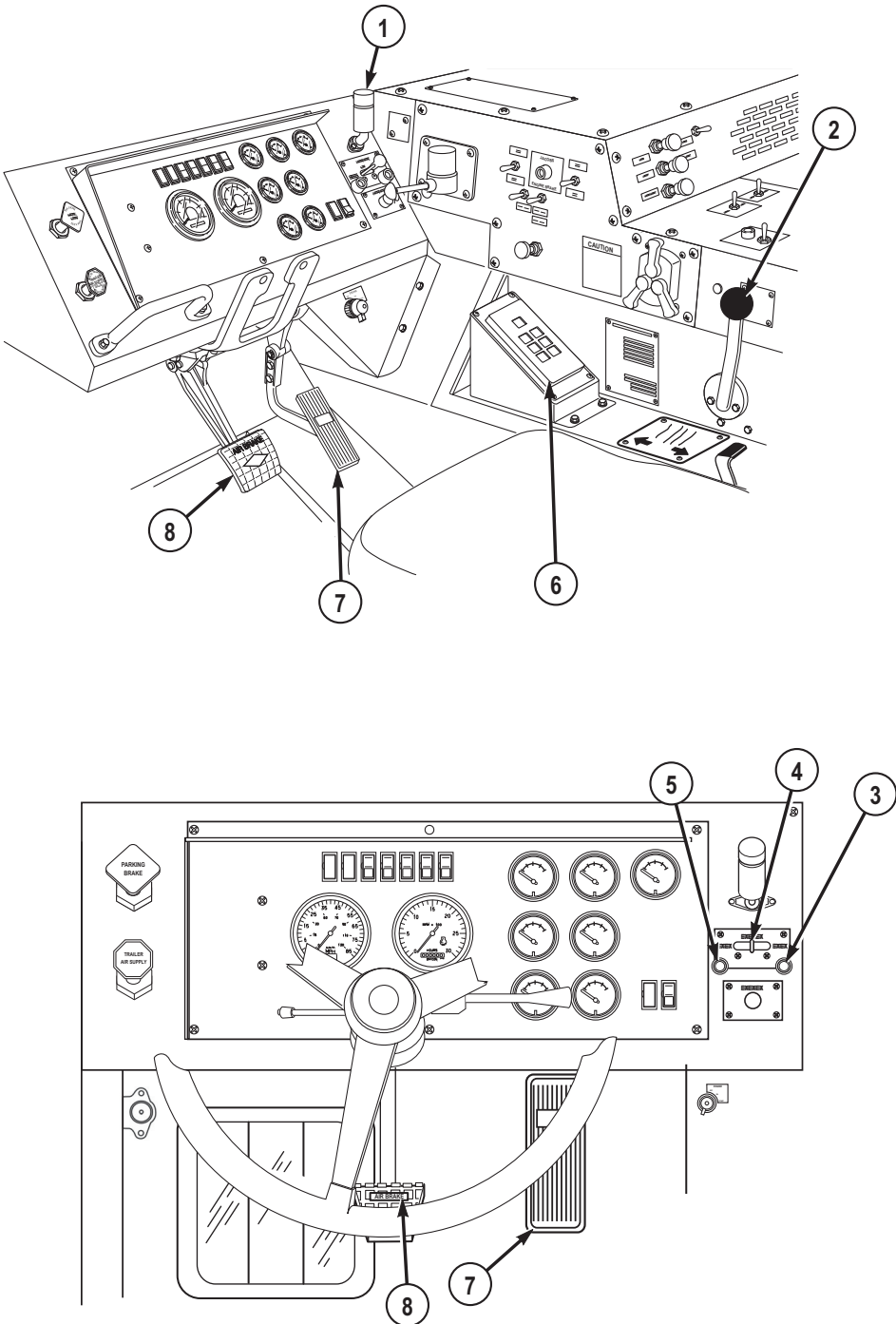

Figure 1.

OPERATE VEHICLE IN SAND OR MUD - Continued**CAUTION**

Wheel hop condition should be avoided to prevent possible damage to drivetrain. If wheel hop begins to occur, ease up on throttle to allow tires to grip surface. If wheel hop continues, release throttle and apply brakes. Apply throttle slowly as traction permits.

4. Start slowly. Do not spin wheels when starting to move vehicle.
5. Set TRACTION CONTROL lever (4) to INTER-AXLE DIFF LOCK for added traction. Indicator light (5) will illuminate.
6. Set transmission range selector (6) to 2 (2nd) or 1 (1st), as needed for added traction.
7. Do not straddle sand mounds or drive on sides of two sand mounds. Loose sand will not support vehicle on steep slopes.
8. Keep throttle pedal (7) steady after vehicle reaches desired speed.
9. Turn vehicle slowly when on loose sand or mud.
10. Steer vehicle straight up and down hills if possible.
11. To move vehicle forward and turn after vehicle is stopped in loose sand or mud, do the following:
 - a. Set transmission range selector (6) to R (reverse).
 - b. Press throttle pedal (7) and move vehicle straight back about 20 ft. (6.1 m).
 - c. Release throttle pedal (7) and press service brake pedal (8).
 - d. Set transmission range selector (6) to 1 (1st).
 - e. Release service brake pedal (8) and press throttle pedal (7) to move vehicle forward.
 - f. Turn vehicle gradually.
 - g. Set transmission range selector (6) to D (drive) when vehicle picks up speed and is moving forward smoothly.
12. If vehicle starts to skid, do the following:
 - a. Release throttle pedal (7).
 - b. Steer in direction of skid until vehicle stops skidding.
 - c. Press throttle pedal (7) slowly and steer vehicle on straight course.

OPERATE GROVE CRANE IN SAND OR MUD**CAUTION**

Take necessary precautions to ensure a firm footing for the crane outriggers by using a field-expedient blocking underneath the outrigger pads. Refer to FM 4-30.31 for additional information on vehicle recovery operations.

NOTE

Lubricate outrigger bottom plate, boom wear pads, and exposed rotation gears often when cranes are operating in dusty environment (refer to PMCS - Semiannual procedures (WP 0149) for more information).

1. When operating a grove crane in a blowing sand environment, perform the following:
2. Check gear teeth of rotation gear bearing and pinion for an accumulation of sand within the lubricant.

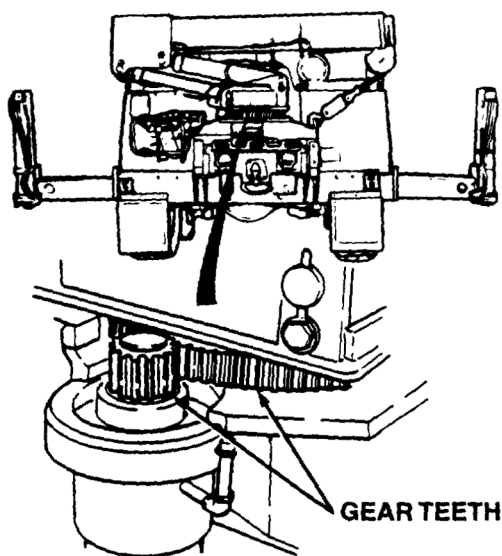

Figure 2.

3. If level of sand prevents rotation of crane, notify field level maintenance and have lubricant removed.
4. If necessary, notify field level maintenance to apply a light coating of wax to gear teeth for rust prevention.
5. Refer to PMCS for proper lubrication of gear teeth when returning to normal operating conditions.

PARK VEHICLE

1. Park vehicle as follows:
 - a. Vehicle should not face into wind.
 - b. Clean mud off vehicle as soon as possible.

CAUTION

- Do not hit axle breathers when cleaning mud from axles.
 - Do not direct high pressure water stream at glass surfaces, seals, air intake, axle breathers, exhaust outlet, or any other component of vehicle that could be easily damaged by high pressure water stream.
2. Clean mud from wheels, brakes, axles, universal joints, steering mechanism, and radiator as soon as possible.
 3. Make sure axle breather vent caps move freely on breather body.

END OF TASK**END OF WORK PACKAGE**

**OPERATOR MAINTENANCE
OPERATE VEHICLE IN DESERT ENVIRONMENT**

INITIAL SETUP:

Not Applicable

DESERT ENVIRONMENT OPERATION**NOTE**

FM 90-3 contains detailed instructions for living and working in desert.

1. Principles for operating in extreme heat (WP 0092) and extreme dust (WP 0093), sand, or mud (WP 0094) apply to desert environment.

NOTE

- Close heater valves to improve the efficiency of cabin air conditioning kit.
 - Closing the heater valves disables cabin heat.
2. Temperatures may change as much as 70°F (21°C) degrees between day and night. These changes may damage equipment if vehicle is not properly prepared.
 - a. Due to expansion and contraction of all fluids and air, care should be taken when filling fuel tank and fluid reservoirs to prevent overflow when temperatures change.
 - b. Precision instruments may be affected by temperature changes and may need adjustment more often.

END OF TASK**END OF WORK PACKAGE**

OPERATOR MAINTENANCE
OPERATE VEHICLE IN COLD ENVIRONMENT (32°F [0°C] TO -25°F [-32°C])

INITIAL SETUP:

Not Applicable

OPERATE VEHICLE IN COLD ENVIRONMENT

WARNING



Do not touch extremely cold metal (below -26°F, -32°C to -65°F, -54°C). Bare skin may freeze to cold metal. Failure to comply may result in injury or death to personnel.

CAUTION

- Before operating vehicle in extreme cold environment, ensure engine arctic kit is installed and vehicle has been prepared as described in FM 9-207 . Refer to FM 31-70 , FM 31-71 , and FM 21-305 for additional information on operations in extreme cold environment.
- Watch instrument panel closely. If any unusual readings occur, stop vehicle and shut off engine. Check engine immediately.
- Park in shelter when possible. If shelter is not available, park so vehicle does not face into wind. Place planks or brush under wheels so vehicle will not freeze in place.
- Fuel filter should be drained before topping off fuel tank. Keep fuel tank as full as possible during cold operations. Water forms in empty fuel tank as it cools. Water in fuel system could freeze and block system.
- All snow and ice should be removed from vehicle as soon as possible. Snow and ice may slow or stop movement of critical parts if allowed to pile up.
- Special care must be used during operations in extreme cold environment. In extreme cold, engine coolant and fluid in windshield

OPERATE VEHICLE IN COLD ENVIRONMENT - Continued

washer can freeze. Batteries can freeze and crack. Oil and grease may get thick and stiff. Rubber and metal parts may crack or become brittle and break easily.

- Proper component lubrication is a must for extreme cold operation.

1. Install tire chains, as needed. (WP 0084)

NOTE

Use ether start system when starting a cold engine.

2. Start engine (WP 0044) and allow engine warm up thoroughly.
3. Let engine warm up thoroughly.

NOTE

Positioning TRANSFER CASE shift lever to LO automatically activates 8X8 drive.

4. Set TRANSFER CASE shift lever (1) to LO. 8X8 DRIVE indicator (2) will illuminate.

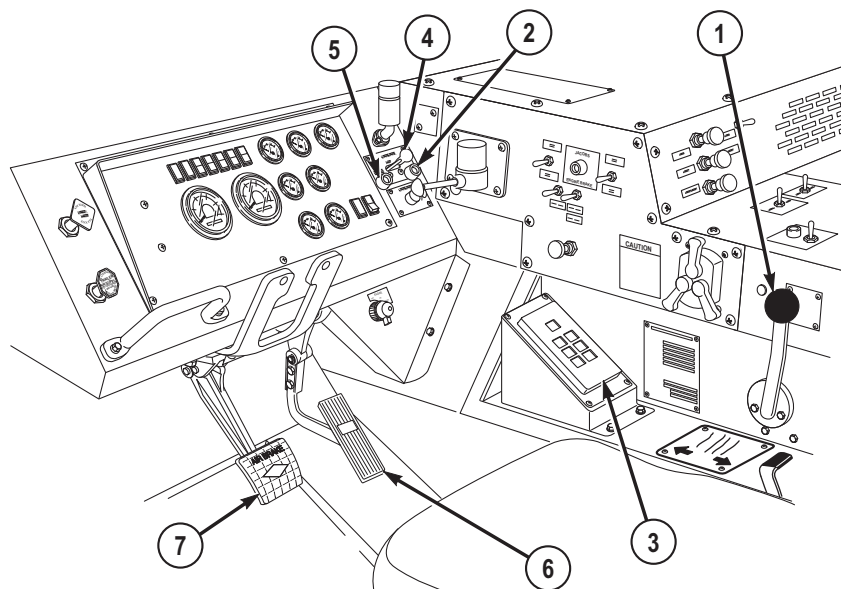

Figure 1.

5. Set transmission range selector (3) to 1 (1st gear range) and drive at lowest possible speed to warm driveline components and tires.

OPERATE VEHICLE IN COLD ENVIRONMENT - Continued

6. Drive on mud, snow, ice, and slippery surfaces as follows:

NOTE

- TRACTION CONTROL lever should be set to 8X8 DRIVE when transfer case shift lever is set to HI range while driving on slippery surfaces.
 - Positioning TRANSFER CASE shift lever to LO automatically activates 8X8 drive.
- a. Set TRANSFER CASE shift lever (1) to LO for added traction. 8X8 DRIVE indicator (2) will illuminate.

NOTE

TRACTION CONTROL lever should be set to INTER-AXLE DIFF. LOCK when transfer case shift lever is set to LO range while driving on slippery surfaces.

- b. Set TRACTION CONTROL lever (4) in INTER-AXLE DIFF LOCK (when LO range is used - recommended) or 8X8 DRIVE (if HI range is required), as needed, when driving on slippery surfaces. INTER-AXLE LOCK indicator (5) and/or 8X8 DRIVE indicator (2) will illuminate as applicable.
- c. Press throttle pedal (6) slowly when changing speed.
- d. Keep throttle pedal (6) steady after vehicle reaches desired speed.
- e. Turn vehicle slowly when on slippery surfaces.
- f. Steer vehicle away from ruts and large snowbanks.
- g. Steer vehicle straight up and down hills if possible.
- h. Use gear range 2 (2nd) or 3 (3rd) to go down medium grades.
- i. Use gear range 1 (1st) to go down steep or very slippery grades.
- j. Drive at slower speeds and stay twice normal distance from vehicle ahead.
- k. Signal turns sooner than normal to give vehicles behind ample time to safely slow down.

OPERATE VEHICLE IN COLD ENVIRONMENT - Continued**WARNING**

Do not use engine brake when vehicle is on slippery surface. If engine brake is used incorrectly, vehicle may skid out of control. Failure to comply may result in injury or death to personnel.

NOTE

Pressing service brake pedal lightly will help keep vehicle from skidding.

- i. Apply brakes sooner, and press service brake pedal (7) lightly to give early warning that vehicle will slow or stop.
- m. Downshift, if necessary, when slowing or stopping vehicle on slick surfaces.
- n. Keep windshield, windows, mirrors, headlights, stoplights, and body lights clean and free of snow and ice. Use defroster and windshield wipers to keep windshield free of snow and ice.
- o. Drive slowly and test brakes after driving through slush or water. If brakes slip, do the following:
 - (1) Continue to drive slowly.
 - (2) Apply moderate pressure on service brake pedal (7) to cause slight brake drag.
 - (3) When brakes are dry and no longer slip, release service brake pedal (7).
 - (4) Resume normal driving speed for conditions.
- p. If absolutely necessary for better traction, lower vehicle tire pressure to emergency air pressure limit:
 - (1) Ensure each tire has a valve cap.
 - (2) Drive at low speed when tire pressures are reduced.
- q. If rear of vehicle skids, do the following:
 - (1) Ease up on throttle pedal (6).
 - (2) Steer in same direction that vehicle is skidding.
 - (3) When vehicle is under control, lightly apply service brake pedal (7).
 - (4) Steer vehicle on a straight course and slowly apply throttle pedal (6).

OPERATE VEHICLE IN COLD ENVIRONMENT - Continued

- r. If vehicle starts to slide while climbing a grade, do the following:
 - (1) Ease up on throttle pedal (6).
 - (2) Steer in same direction that vehicle is skidding.
 - (3) Slowly apply throttle pedal (6) and steer vehicle on a straight course.
 - s. If vehicle becomes stuck, do the following:
 - (1) Shovel a clear path ahead of each tire.
 - (2) Put boards, brush, or similar material in cleared paths to get better traction.
 - (3) If vehicle remains stuck, use another vehicle to winch or tow stuck vehicle clear.
 - (4) If another vehicle is not available, self-recover vehicle using self-recovery winch. (WP 0087)
7. Park vehicle (WP 0056) as follows:

NOTE

If no shelter is available, park vehicle so it does not face into the wind. Vehicle facing opposite of the direction of the wind is optimal.

- a. Park vehicle in sheltered area, out of wind if possible.

NOTE

If no high, dry ground is available, spread out planks, brush, etc., to create a raised area so that vehicle tires will not freeze in snow, water, ice, or mud.

- b. Park vehicle on high, dry ground if possible.
- c. Park vehicle on level ground so vehicle body does not twist.
- d. Leave transfer case shift lever (1) in LO.

NOTE

Do not hit axle breathers when cleaning mud, snow, and ice from axles.

- 8. Clean snow, ice, and mud off vehicle as soon as possible.
- 9. Clean mud, snow, and ice from wheels, brakes, axles, universal joints, mirrors, steering mechanism, and radiator as soon as possible.

OPERATE VEHICLE IN COLD ENVIRONMENT - Continued

10. Ensure axle breather vent caps move freely on breather body.

END OF TASK

END OF WORK PACKAGE

OPERATOR MAINTENANCE OPERATION IN EXTREME COLD ENVIRONMENT

INITIAL SETUP:

Not Applicable

OPERATE VEHICLE IN EXTREME COLD ENVIRONMENT (-26°F[-32°C] to -65°F[-54°C])

WARNING

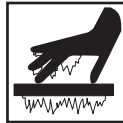

Do not touch extremely cold metal (below -26°F, -32°C to -65°F, -54°C). Bare skin may freeze to cold metal. Failure to comply may result in injury or death to personnel.

CAUTION

- Before operating vehicle in extreme cold environment, ensure engine arctic kit is installed and vehicle has been prepared as described in FM 9-207.
- Refer to FM 31-70 , FM 31-71 , and FM 21-305 for additional information on operations in extreme cold environment.
- Watch instrument panel closely. If any unusual readings occur, stop vehicle and shut off engine. Check immediately.
- Park in shelter when possible. If shelter is not available, park so vehicle does not face into wind. Place planks or brush under wheels so vehicle will not freeze in place.
- Fuel filter should be drained before topping off fuel tank. Keep fuel tank as full as possible during cold operations. Water forms in empty fuel tank as it cools. Water in fuel system could freeze and block system.
- All snow and ice should be removed from vehicle as soon as possible. Snow and ice may slow or stop movement of critical parts if allowed to pile up.

OPERATE VEHICLE IN EXTREME COLD ENVIRONMENT (-26°F[-32°C] to -65°F[-54°C]) - Continued

- Special care must be used during operations in extreme cold environment. In extreme cold, engine coolant and fluid in windshield washer can freeze. Batteries can freeze and crack. Oil and grease may get thick and stiff. Rubber and metal parts may crack or become brittle and break easily.
 - Proper component lubrication is a must for extreme cold operation.
1. Principles and procedures for operating in cold environment (WP 0096) also apply to extreme cold environment.
 2. Ensure arctic engine heater kit has been installed.
 3. Operate arctic engine heater (WP 0058) as needed.

WARNING

Do not touch extremely cold metal (below -26°F, -32°C to -65°F, -54°C). Bare skin may freeze to cold metal. Failure to comply may result in injury or death to personnel.

NOTE

If additional air is put in tires for standby periods, lower tire pressure to normal amounts before driving vehicle.

4. In areas where temperatures reach -50°F (-46°C) or colder, fill tires with air approximately 10 psi above normal for long standby periods and overnight.

OPERATE GROVE CRANE IN EXTREME COLD ENVIRONMENT (-26°F[-32°C] to -65°F [-54°C])**WARNING**

Do not touch extremely cold metal (below -26°F, -32°C to -65°F, -54°C). Bare skin may freeze to cold metal. Failure to comply may result in injury or death to personnel.

OPERATE GROVE CRANE IN EXTREME COLD ENVIRONMENT (-26°F[-32°C] to -65°F [-54°C]) - Continued

1. Before operating crane, perform warm-up as follows:
 - a. Start engine. (WP 0044)
 - b. Properly warm up vehicle.
 - c. Set PTO ENGAGE switch (1) to ON position. Indicator light (2) will illuminate.

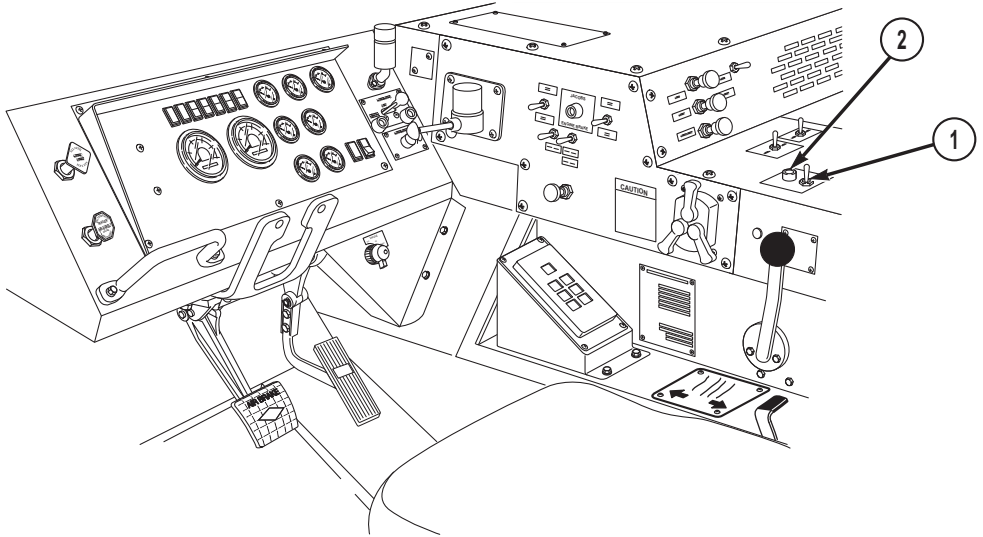

Figure 1.

- d. While engine is at low idle, fully exercise all functions of crane for at least 5 minutes.
 - e. With engine at high idle, fully exercise all functions of crane for at least 10 minutes.
2. Continue with operation of crane.

END OF TASK

END OF WORK PACKAGE

**OPERATOR MAINTENANCE
OPERATE VEHICLE IN FOREST OR ROCKY TERRAIN**

INITIAL SETUP:

Not Applicable

OPERATE VEHICLE IN FOREST OR ROCKY TERRAIN

WARNING



Ensure tire pressure is correct for vehicle operation. Failure to comply may result in injury or death to personnel.

NOTE

When driving over very rocky terrain is part of the mission route, be sure spare wheel and tire are on vehicle, in good repair, and at correct pressure for normal operations. There is greater chance of tire punctures when operating in rocky terrain.

1. Fold vehicle side mirrors in far enough so area to rear of vehicle can still be seen, but mirrors will not be damaged by rocks, trees, and other obstructions.

CAUTION

Before driving over ground obstructions such as stumps and large rocks, ensure vehicle has adequate clearance. Stumps and rocks may damage components underneath vehicle.

2. Avoid driving over obstructions if possible.

CAUTION

Ensure vehicle can clear overhanging tree limbs and other obstructions. Low overhead obstructions may damage cargo, cargo cover, and other parts on top of vehicle.

3. Avoid low overhanging obstructions if possible.

OPERATE VEHICLE IN FOREST OR ROCKY TERRAIN - Continued

4. Check traction and braking. Rocks and fallen leaves can be very slick, especially when wet.

END OF TASK

END OF WORK PACKAGE

**OPERATOR MAINTENANCE
OPERATE VEHICLE IN SALTWATER AREAS**

INITIAL SETUP:

Not Applicable

OPERATION

1. Inspect vehicle and major components (crane, tanker module, LHS, etc.) frequently for the buildup of salt deposits, rust, and corrosion.

NOTE

Do not direct high-pressure water hose nozzles, or steam cleaner nozzles into hydraulic system seals and/or electrical junction boxes.

2. If salt deposits are located, clean the affected areas using authorized local procedures.
3. Frequently wash the vehicle and major components to prevent the buildup of salt deposits.
4. If corrosion is present, notify your supervisor as these conditions need to be corrected immediately.

END OF TASK**END OF WORK PACKAGE**

**OPERATOR MAINTENANCE
SET UP/SECURE HIGHWAY EMERGENCY MARKER KIT**

INITIAL SETUP:

Not Applicable

PREPARE VEHICLE/MARKERS FOR USE

1. Turn vehicle emergency flashers on. (WP 0076)
2. Remove emergency marker kit (1) from stowage brackets (2).

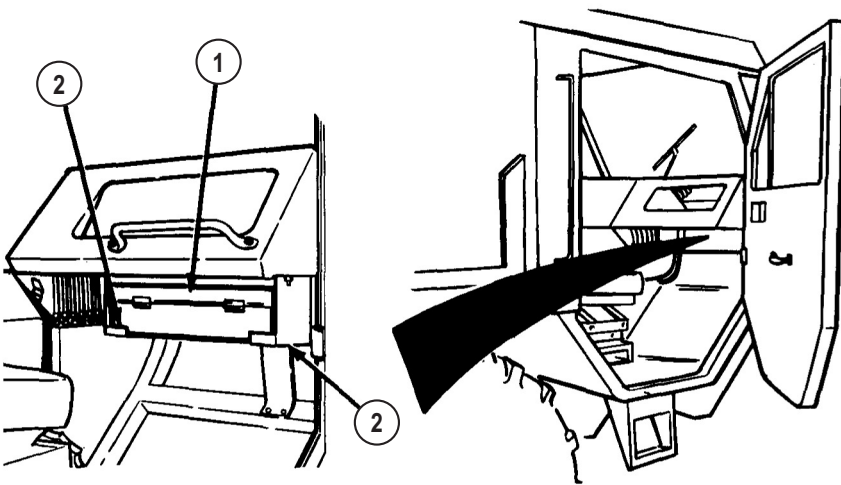

Figure 1.

3. Remove markers (3) from case.

PREPARE VEHICLE/MARKERS FOR USE - Continued

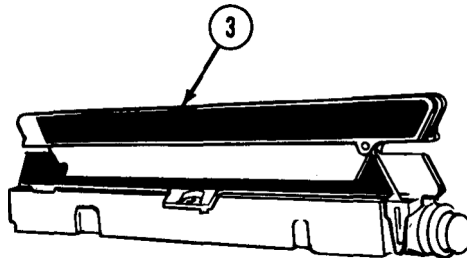

Figure 2.

4. Raise arms (4).

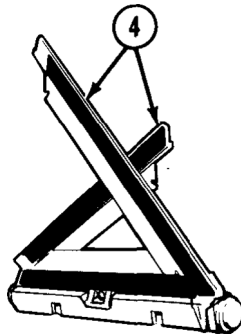

Figure 3.

5. Snap pin (5) into slot (6).

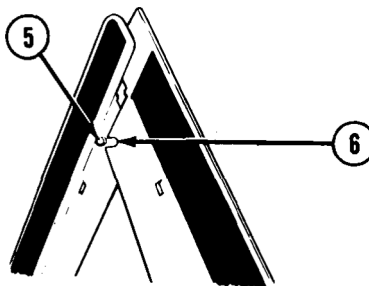
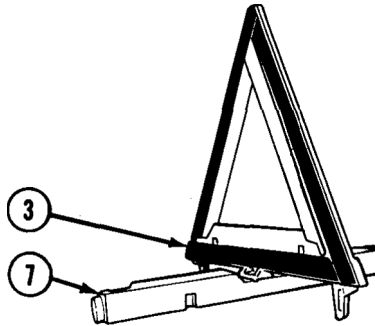
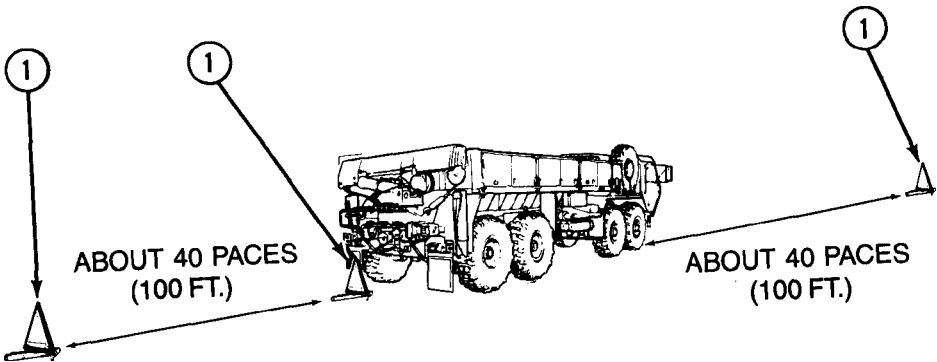

Figure 4.

6. Rotate marker (3) about 1/4 turn on base (7) until it stops.

PREPARE VEHICLE/MARKERS FOR USE - Continued*Figure 5.***PLACE MARKERS ON UNDIVIDED HIGHWAY**

1. Place one marker (1) about 40 paces (100 ft. [30 m]) in front of vehicle, so marker faces traffic approaching from front.

*Figure 6.*

2. Place another marker (1) directly behind vehicle, so marker faces traffic approaching from rear.
3. Place third marker (1) approximately about 40 paces (100 ft. [30 m]) behind vehicle, so marker faces traffic approaching from rear.

PLACE MARKERS ON DIVIDED HIGHWAY

1. Place one marker (1) directly behind vehicle, so marker faces traffic approaching from rear.

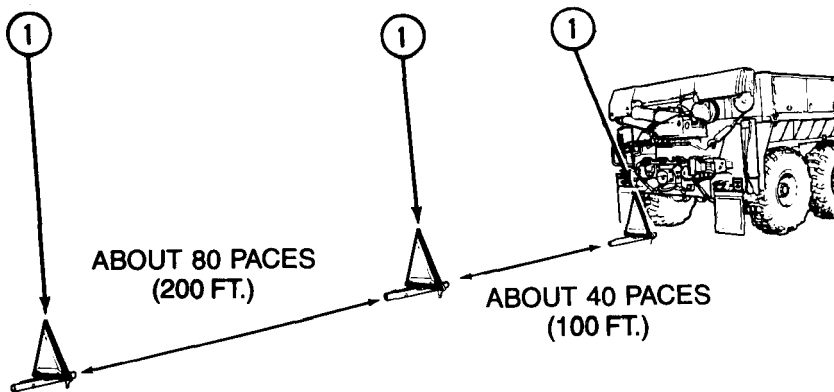
PLACE MARKERS ON DIVIDED HIGHWAY - Continued*Figure 7.*

2. Place second marker (1) about 40 paces (100 ft. [30 m]) behind vehicle, so marker faces traffic approaching from rear.
3. Place third marker (1) about 80 paces (200 ft. [60 m]) behind second marker, so marker faces traffic approaching from rear.

SECURE MARKERS

1. Rotate marker (1) over base (2).

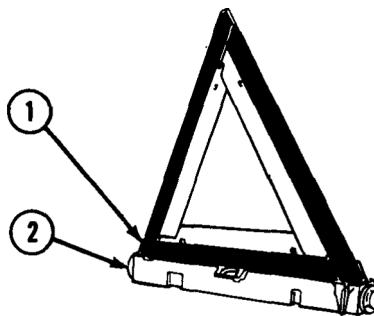
*Figure 8.*

2. Separate arms (3).

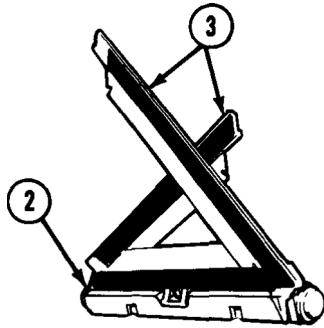
SECURE MARKERS - Continued*Figure 9.*

3. Fold arms (3) down onto base (2).

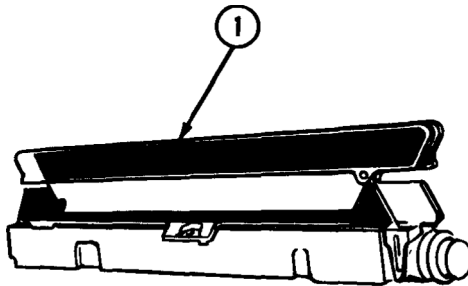
*Figure 10.*

4. Put markers (1) in case.
5. Put emergency marker kit (4) in stowage brackets (5).

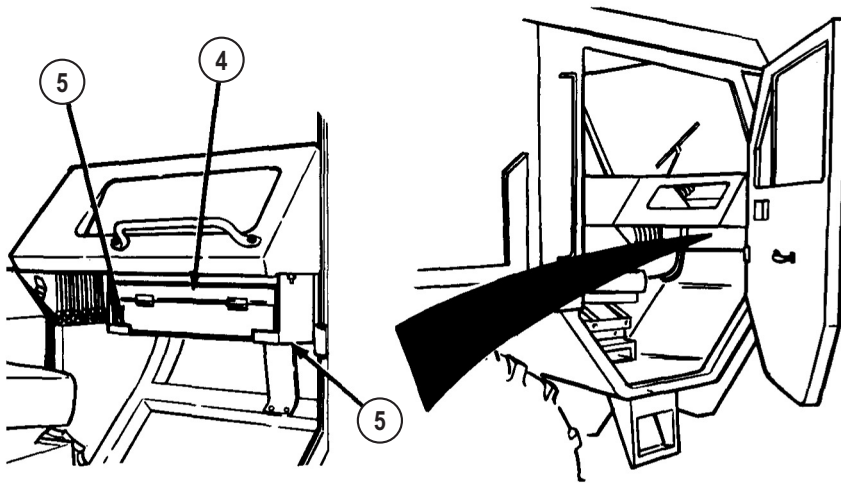
SECURE MARKERS - Continued*Figure 11.*

6. Turn vehicle emergency flashers off. (WP 0076)

END OF TASK

END OF WORK PACKAGE

**OPERATOR MAINTENANCE
MANUALLY RELEASE SPRING BRAKES**

INITIAL SETUP:

Not Applicable

CHOCK REAR WHEELS**NOTE**

This procedure should only be used when vehicle air system is totally inoperative and vehicle cannot be towed with rear end raised by wrecker.

1. Remove wheel chocks (1) from stowage.

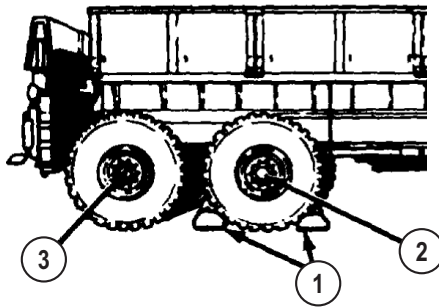

Figure 1.

2. Place wheel chocks (1) in front and back of one wheel on No. 3 (2) or No. 4 (3) axle.

RELEASE BRAKES**WARNING**

Ensure brake chamber is caged while releasing brakes. Spring is under 2,500 lbs (1,136 kg) tension. Failure to comply may result in injury or death to personnel.

NOTE

Driver side brake chamber on No. 4 axle is shown. Steps are same for No. 4 axle passenger side and No. 3 axle.

1. Remove dust cap (1) from brake chamber (2).

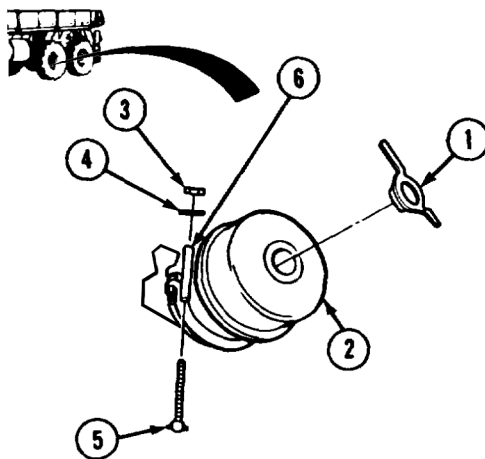
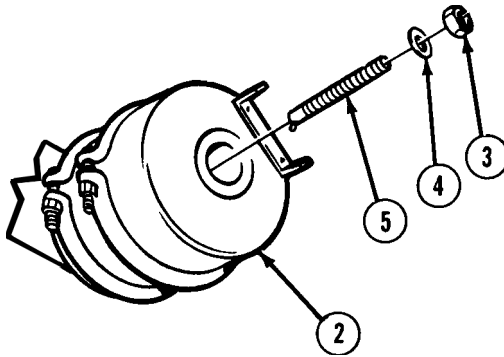
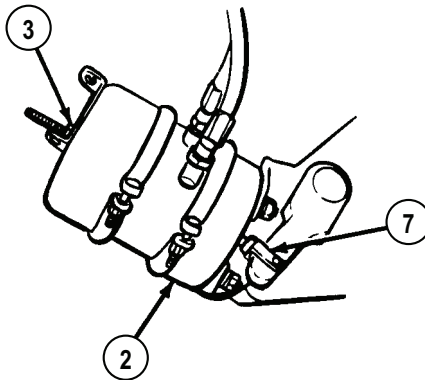

Figure 2.

2. Remove nut (3), washer (4), and release-bolt (5) from bracket (6).
3. Insert release-bolt (5) into brake chamber (2).

RELEASE BRAKES - Continued*Figure 3.*

4. Turn release-bolt (5) 1/4 turn to engage inside brake chamber (2).
5. Install washer (4) and nut (3) on release-bolt (5).
6. Tighten nut (3) until clevis (7) is pulled to rear of brake chamber (2).

*Figure 4.*

7. Repeat Steps (1) through (6) to release three remaining spring brakes on No. 3 and No. 4 axles.

END OF TASK**END OF WORK PACKAGE**



**OPERATOR MAINTENANCE
SLAVE START VEHICLE**

INITIAL SETUP:**Personnel Required**Operator and Assistant - - - (2)

PREPARE ASSIST VEHICLE**NOTE**

This procedure is a two soldier task.

1. Start engine of assist vehicle. (WP 0044)

NOTE

- Model of truck can be determined by information plate on inside of driver side cabin door.
 - Base Model HEMTT - Slave receptacle may be located either on battery box or driver side front fender.
 - A2 Model HEMTT - Slave receptacle is located on driver side front fender.
 - A4 Model HEMTT - Slave receptacle is located on driver side front fender.
2. Move assist vehicle into position beside disabled vehicle so slave receptacles (1) on both vehicles are side by side.

PREPARE ASSIST VEHICLE - Continued

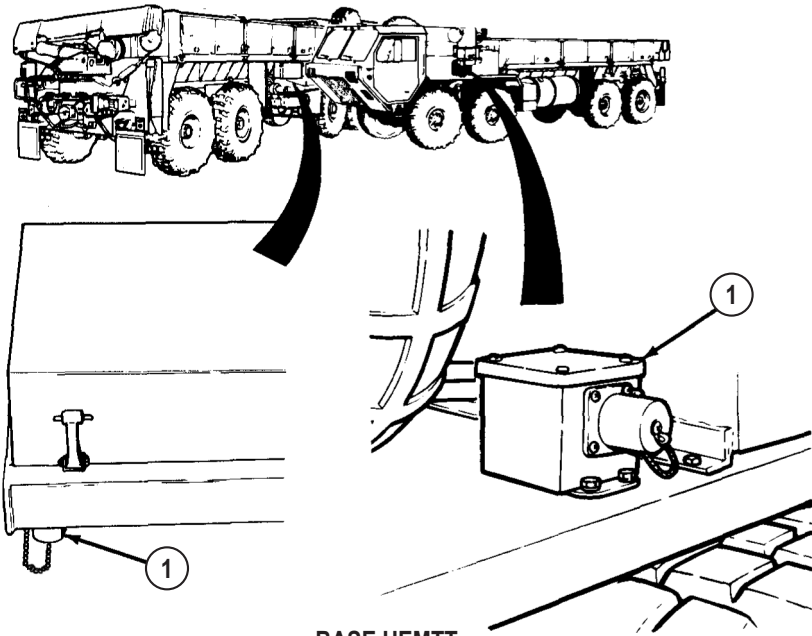

BASE HEMTT

Figure 1.

PREPARE ASSIST VEHICLE - Continued

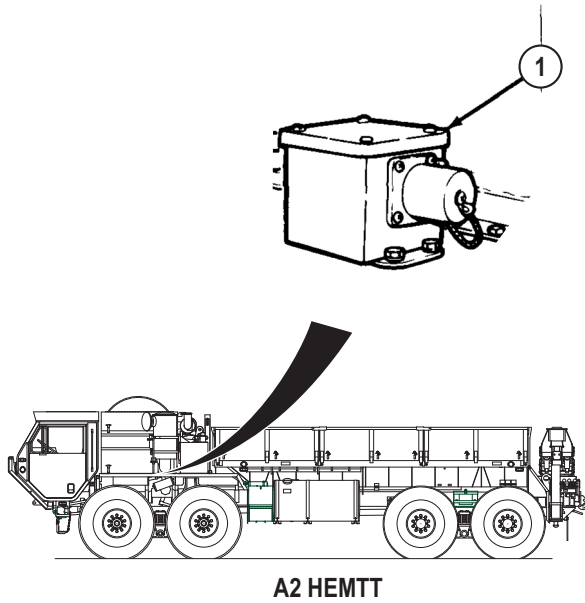

Figure 2.

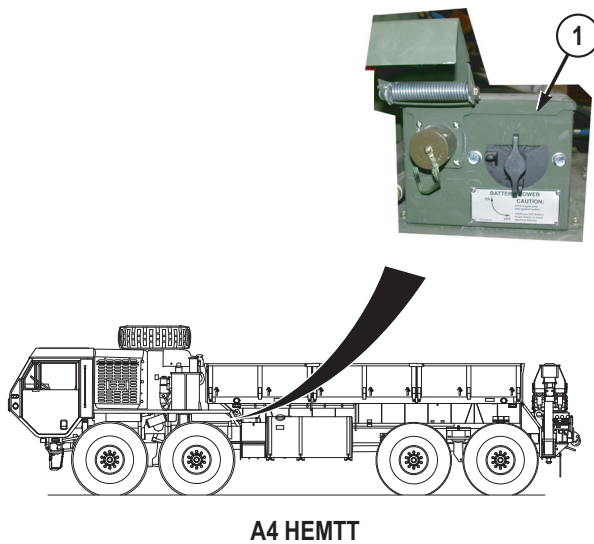

Figure 3.

3. Shut off engine of assist vehicle. (WP 0057)

SLAVE START DISABLED VEHICLE**NOTE**

- Model of truck can be determined by information plate on inside of driver side cabin door.
- Base Model HEMTT - Slave receptacle may be located either on battery box or driver side front fender.
- A2 Model HEMTT - Slave receptacle is located on driver side front fender.
- A4 Model HEMTT - Slave receptacle is located on driver side front fender.

1. Remove caps (2) from slave receptacles (1) on both vehicles.

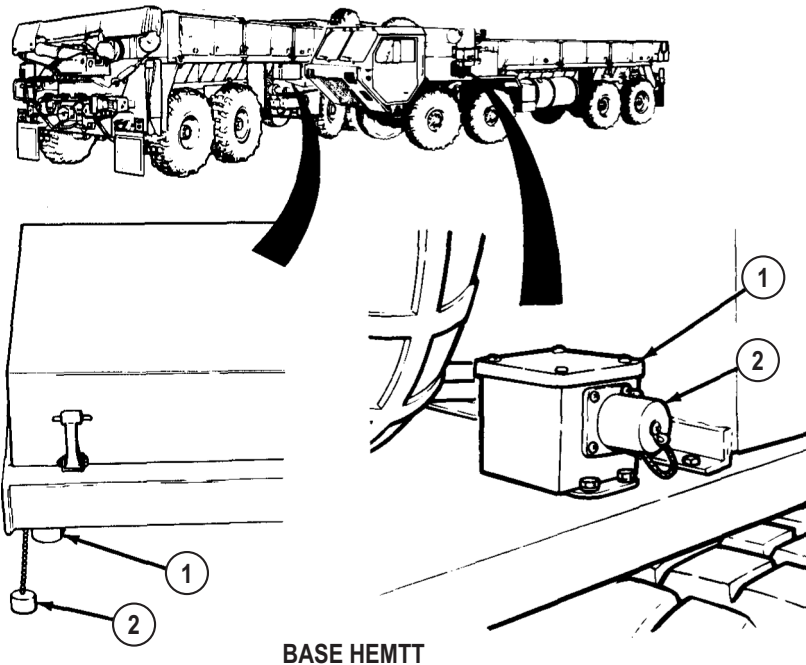
*Figure 4.*

SLAVE START DISABLED VEHICLE - Continued

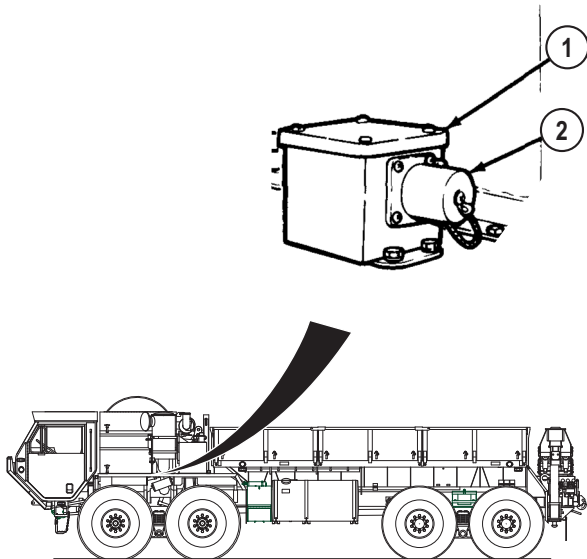

A2 HEMTT

Figure 5.

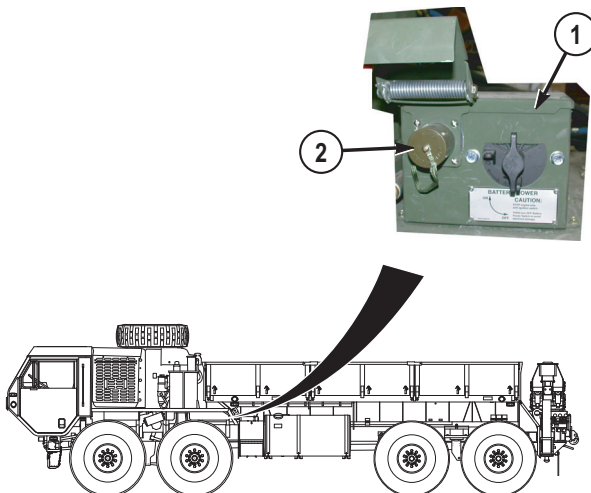

A4 HEMTT

Figure 6.

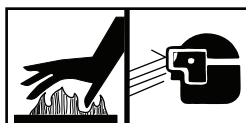
SLAVE START DISABLED VEHICLE - Continued**WARNING**

Hot transmission/oil can cause severe burns. Wear gloves and proper eye protection while performing troubleshooting or maintenance. Failure to comply may result in injury or death to personnel.

NOTE

Make sure connectors and receptacles are free from dirt, sand, and debris before use.

2. Remove NATO slave cable from stowage and plug into slave receptacles of both vehicles.
3. Start engine of assist vehicle. (WP 0044)
4. Using the throttle pedal, increase assist vehicle engine speed to more than 1000 rpm, while assistant starts engine of disabled vehicle. (WP 0044)
5. As soon as disabled vehicle engine is running smoothly, remove NATO slave cable from slave receptacles (1) on both vehicles and return to stowage.
6. Install caps (2) on slave receptacles (1) of both vehicles.
7. Move assist vehicle. (WP 0050)
8. Shut off engine of assist vehicle. (WP 0057)

NOTE

- Model of truck can be determined by information plate on inside of driver side cabin door.
 - A4 Model HEMTT does not have an AMPERES gauge. Battery voltage readout is located in top right corner of Liquid Crystal Display (LCD) on instrument panel.
 - Gauges are located in different places dependant on model HEMTT. Select correct view below for model HEMTT being serviced.
9. Check BATTERY gauge (3) of disabled vehicle. If BATTERY gauge (3) shows less than 24 volts, notify field level maintenance. If BATTERY gauge (3) shows 24 volts or more, continue with Step (11).

SLAVE START DISABLED VEHICLE - Continued

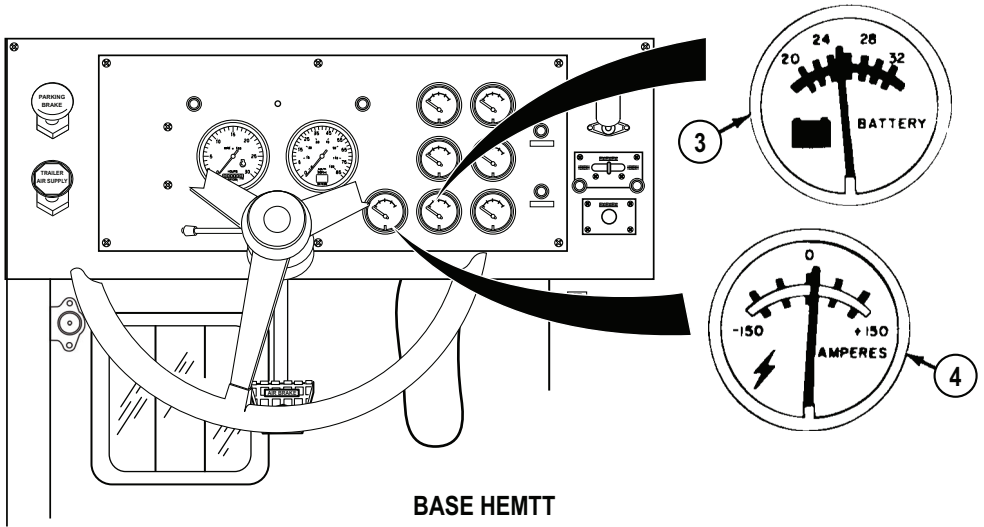

Figure 7.

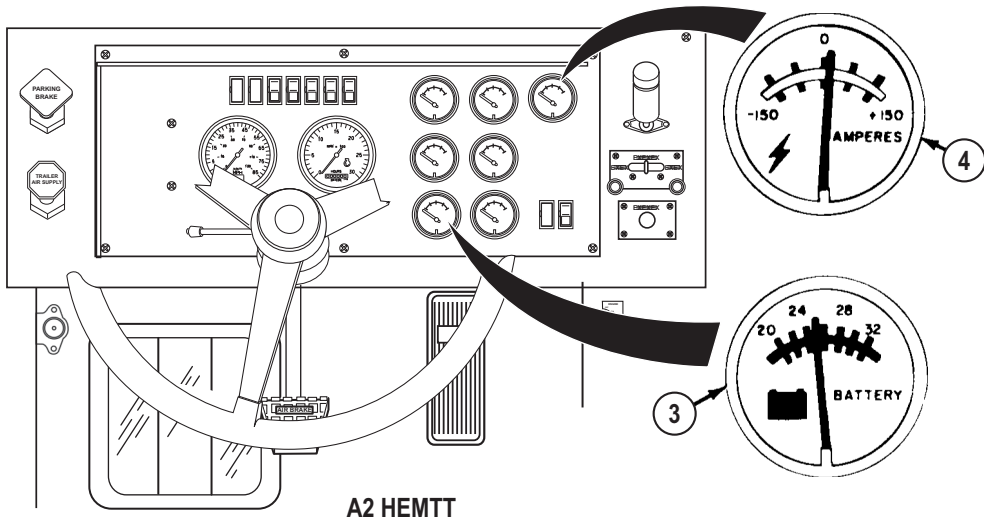
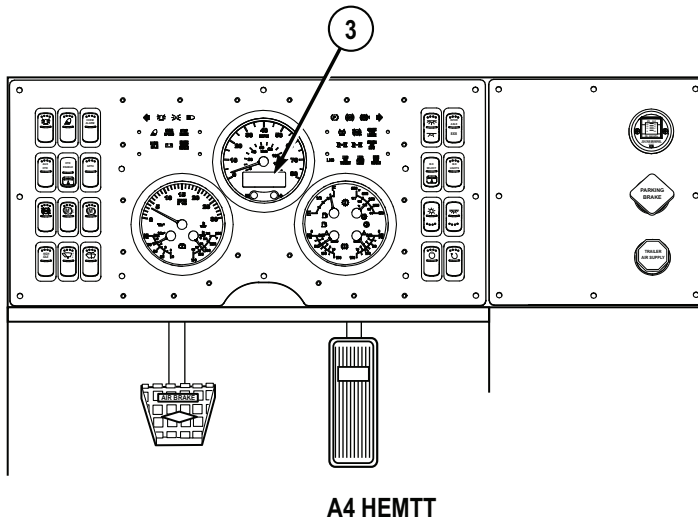

Figure 8.

SLAVE START DISABLED VEHICLE - Continued**A4 HEMTT***Figure 9.*

10. Check AMPERES gauge (4) of disabled vehicle (as applicable). If AMPERES gauge shows discharge condition, notify field level maintenance. If AMPERES gauge (4) shows charging, continue operation of vehicle.

END OF TASK**END OF WORK PACKAGE**

**OPERATOR MAINTENANCE
PERFORM IMMEDIATE ACTION FOR LOSS OF HYDRAULIC SYSTEM**

INITIAL SETUP:

Not Applicable

NOTE

Steering wheel will be harder to turn after failure of hydraulic system.

1. If failure occurs while driving, continue steering as before.

NOTE

Failure of hydraulic system will stop operation of any crane, winch, or hydraulic motor on vehicle. All cranes and winches are equipped with automatic locking mechanisms to hold cranes and winches in position they were in before hydraulics failed.

2. Do not try to continue operation of any crane or winch.
3. Do not try to repair hydraulic system. Notify your supervisor.
4. Notify field level maintenance.

END OF TASK

END OF WORK PACKAGE

**OPERATOR MAINTENANCE
PERFORM EMERGENCY HYDRAULIC OPERATION WHEN GROVE CRANE
ELECTRICAL POWER FAILS**

INITIAL SETUP:

Not Applicable

NOTE

- If crane electrical power systems fails during crane operation, crane will be locked in position it was in at time of failure.
 - Do not try to operate any electrical equipment on vehicle or crane.
 - Do not try to repair electrical system.
 - This procedure will provide emergency hydraulic power to lower crane and load when electrical power has failed.
 - Screwdriver can be put in slot in front of solenoid valve button to hold button in while operating controls.
1. Push up and hold solenoid valve button (1).
 2. Shut down crane.

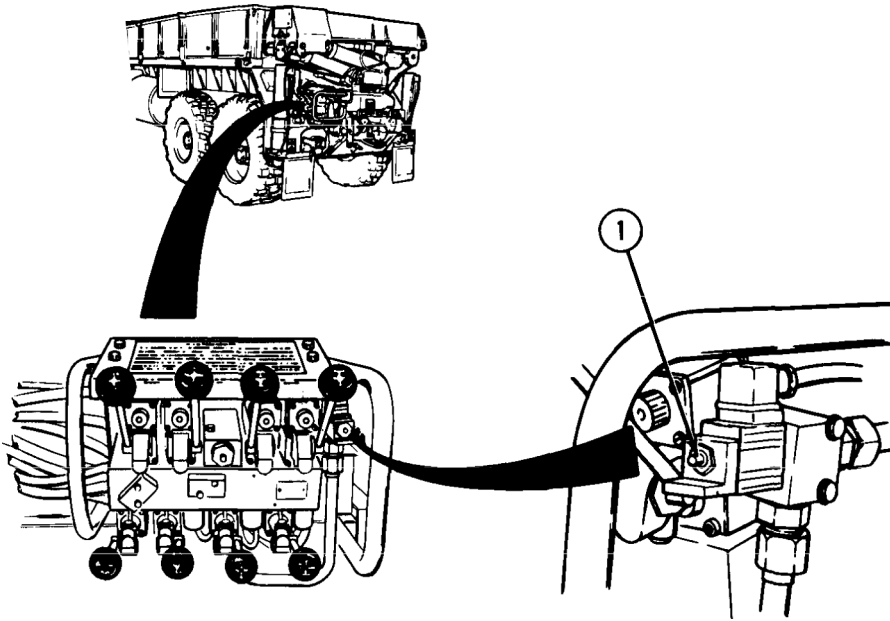

Figure 1.

3. Notify field level maintenance.

END OF TASK

END OF WORK PACKAGE

**OPERATOR MAINTENANCE
LIMP HOME/TRANSMISSION FAULT**

INITIAL SETUP:

Not Applicable

ALLISON 4500SP TRANSMISSION WILL NOT SHIFT INTO OR OUT OF GEAR (CHECK TRANSMISSION INDICATOR ILLUMINATED)

CAUTION

If transmission range selector flashes current range selection while operating vehicle (shift selection is inhibited), **DO NOT SHUT OFF ENGINE** or attempt to change range selection. Shutting off engine may result in the inability to select a drive range at startup, and diagnostic data may be lost. Move vehicle to safe place and notify field level maintenance as soon as possible.

NOTE

- HEMTT A2 series vehicles are equipped with either an Allison model 4500SP (newer) or Allison model HD4560 (older) automatic transmission. The operator is responsible for determining which transmission is applicable to vehicle.
 - This procedure is only applicable to HEMTT series vehicles equipped with Allison model 4500SP.
 - When transmission oil is below 19°F (-7 C), the only gears available are R (reverse), N (Neutral), and 3 (third gear range) when D (drive) is selected. The remaining gears in D (drive) will not be available until transmission oil in sump warms above 19°F (-7 C).
1. If check transmission indicator (1) illuminates when operating vehicle, apply service brake pedal (2) and stop vehicle.

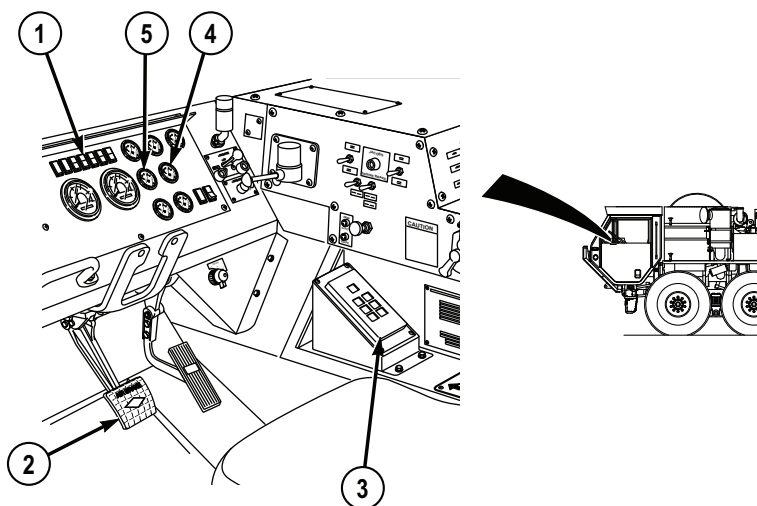
ALLISON 4500SP TRANSMISSION WILL NOT SHIFT INTO OR OUT OF GEAR (CHECK TRANSMISSION INDICATOR ILLUMINATED) - Continued*Figure 1.***NOTE****DO NOT shift transmission to N (neutral).**

2. Set transmission range selector (3) to R (reverse):
 - a. If vehicle DOES shift into R (reverse):
 - (1) Set transmission range selector (3) to appropriate position.
 - (2) Continue with mission, and notify field level maintenance when mission is completed.
 - b. If vehicle DOES NOT shift into R (reverse):

NOTE**The operator must be aware that once the engine is turned off, the vehicle will not be operable until the problem is corrected.**

- (1) The transmission may be locked into specific gear, and may not come out of that gear until the engine is turned off.

ALLISON 4500SP TRANSMISSION WILL NOT SHIFT INTO OR OUT OF GEAR (CHECK TRANSMISSION INDICATOR ILLUMINATED) - Continued**WARNING**

When operating the vehicle in the transmission limp home mode, the operator must not rely on the parking brake to hold the vehicle in place. The service brakes must also be applied. Failure to comply may result in injury or death to personnel.

NOTE

The operator should consider the following guidelines carefully with regard to type of mission, environment, terrain, etc., when deciding on whether to continue the mission, deadline, or return vehicle to field level maintenance.

- (2) No additional damage to the transmission will occur. The operator can continue to operate vehicle in the limp home mode and complete mission. However, the operator must be aware of the following guidelines:
- (a) DO NOT shut off engine until the decision is made to deadline vehicle. Once the engine is shut off, the vehicle will not be operable until the problem is corrected.
 - (b) As the engine cannot be turned off and the transmission is locked into gear, the operator will not be able to leave the cab until vehicle is deadlined.
 - (c) The vehicle will not be able to operate in R (reverse).
 - (d) Depending on gear range the transmission is locked into, the operator may not be able to drive vehicle up steep grades. (WP 0054)
 - (e) The service brake pedal (2) may need to be applied slightly earlier than normal when stopping the vehicle.
 - (f) Depending upon gear range the transmission is locked into and the terrain the vehicle is operating in, the engine and/or transmission may overheat. The operator must closely monitor the engine WATER TEMP gauge (4) and the TRANS TEMP gauge (5).

ALLISON 4500SP TRANSMISSION WILL NOT SHIFT INTO OR OUT OF GEAR (CHECK TRANSMISSION INDICATOR ILLUMINATED) - Continued**CAUTION**

If overheating occurs when operating in the transmission limp home mode, the operator should stop the vehicle (do not shut off engine), and allow the transmission and engine to cool down to normal operating levels. If the engine and transmission do not cool down, or overheating reoccurs, the operator should shut off engine and notify field level maintenance. Failure to comply may result in damage to equipment.

- (g) Notify field level maintenance as soon as possible.

END OF TASK**END OF WORK PACKAGE**

**OPERATOR MAINTENANCE
STOWAGE AND SIGN GUIDE**

Scope

This work package shows locations for data plates, decals, and stencils that are required to be in place on the HEMTT series vehicles.

General

The following figures show the location of metal signs, decals, and stencils used on the vehicle. Most of these signs and stencils contain cautions or information needed to operate the vehicle safely. For stowage locations of Components Of End Item (COEI) and Basic Issue Items (BII), refer to Components of End Item and Basic Issue Items tables. (WP 0162)

Table 1. Inside Driver Side Door.

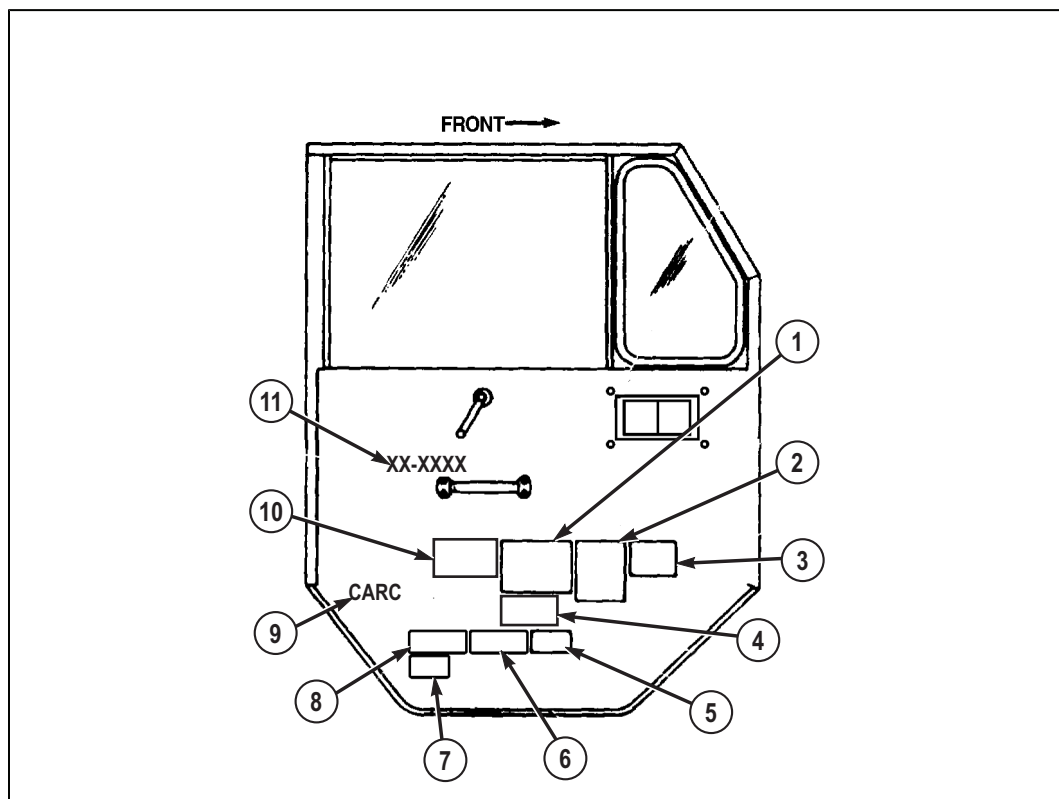

General - Continued

Table 1. Inside Driver Side Door. - Continued

INDEX	DECAL/PLATE/STENCIL
1	Manufacturer's Certification Information
2	Parts Data
3	Name Plate
4	Overhaul Data (not included on all vehicles)
5	Tire Inflation Data
6	Warranty Information
7	Rustproofing Data/Rustproofing CAUTION
8	Noise Exemption Decal
9	"CARC" Stencil
10	Shipping Data
11	Registration Number (inside both driver and passenger side doors)

General - Continued

Table 2. Front Exterior.

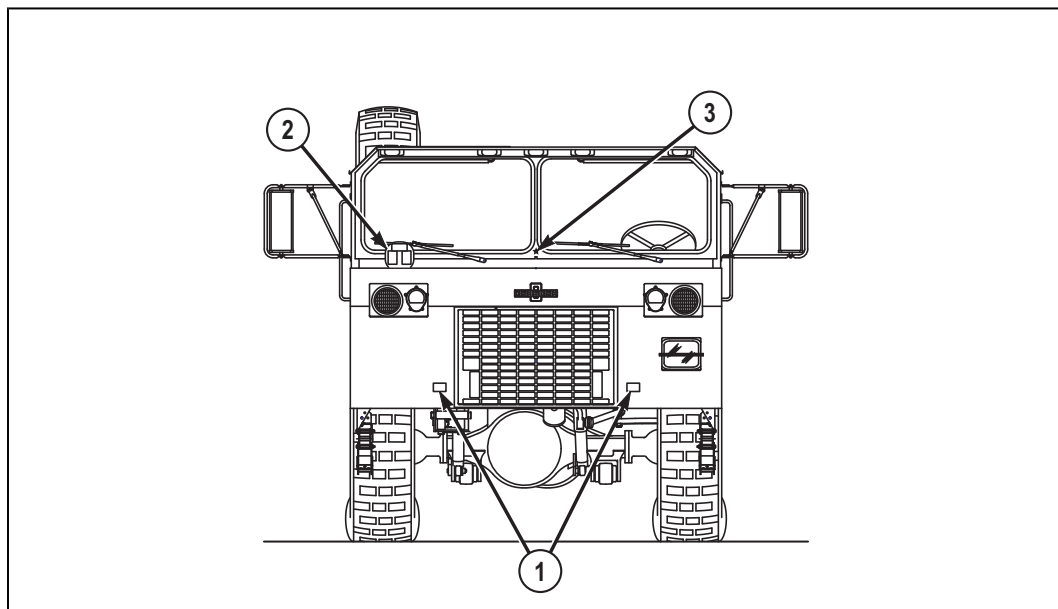

INDEX	PLACARD/STENCIL
1	"TIEDOWN" Stencil
2	Sign Kit/Weight Indicator
3	US Army Star Stencil

General - Continued

Table 3. M977A2 Cargo Cabin.

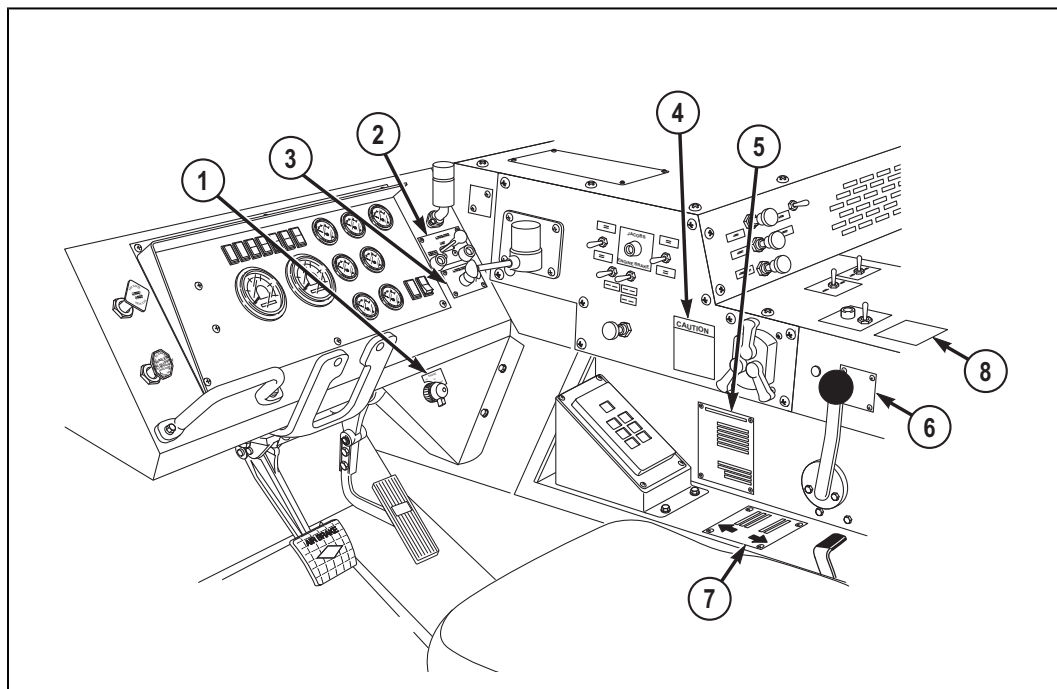

INDEX	DECAL/PLATE
1	Engine ON/OFF Decal
2	Traction Control Data Plate
3	Ether Start Data Plate
4	CAUTION (Transmission) Plate
5	Vehicle Data Plate
6	Transfer Case Data Plate
7	Self-Recovery Winch Data Plate (vehicles equipped with self-recovery winch only)
8	Crane Data Plate

General - Continued

Table 4. M977A2 Cargo Driver Side Exterior.

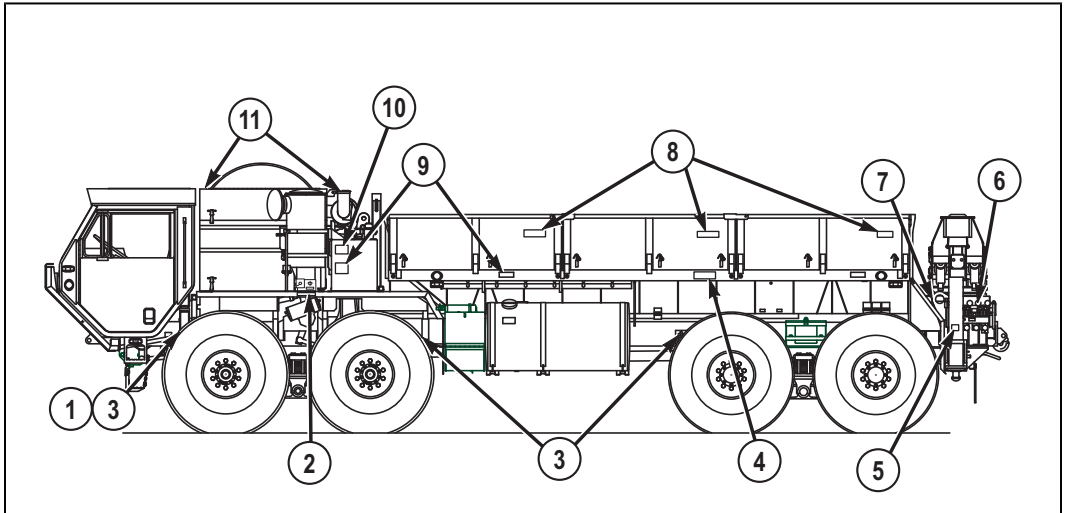

INDEX	DECAL/PLACARD/PLATE/STENCIL
1	Vehicle Identification Number (VIN) Placard
2	"24V" Stencil
3	"TIEDOWN" Stencil
4	"DANGER" Plate
5	Outrigger Instruction Placard
6	"DANGER" Plate (crane operation) and Crane Erection Procedure Steps Placard
7	Engine Speed Data Plate
8	"CAUTION DO NOT ALLOW PANEL TO SLIDE OFF PINS WHEN LOWERING" Stencil
9	CAUTION Decal (hearing protection required)
10	"FULL COLD" Stencil

General - Continued

Table 4. M977A2 Cargo Driver Side Exterior. - Continued

11	"NO STEP" Stencil (multiple on exhaust and engine access panels)
----	---

Table 5. M977A2 Cargo Passenger Side Exterior.

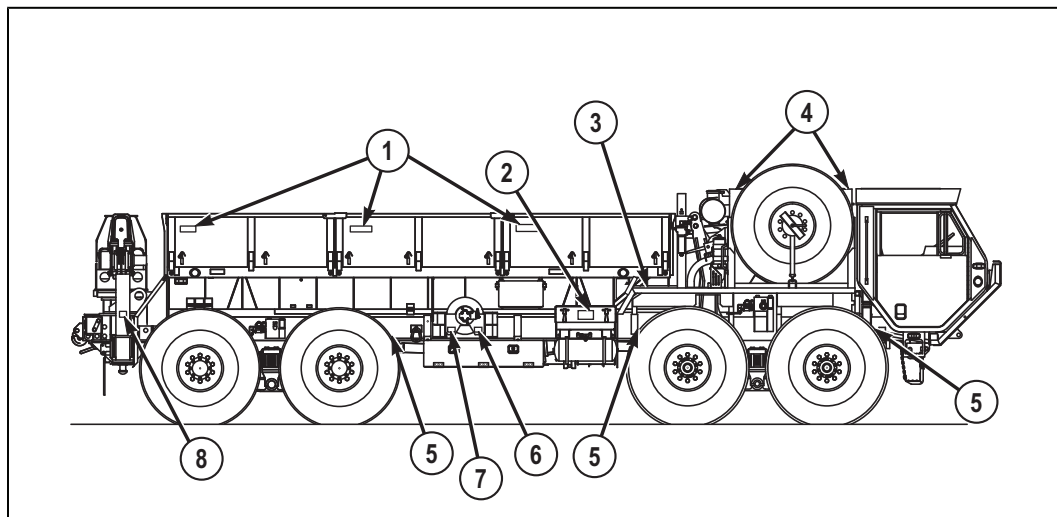

INDEX	DECAL/PLACARD/PLATE/STENCIL
1	"CAUTION DO NOT ALLOW PANEL TO SLIDE OFF PINS WHEN LOWERING" Stencil
2	CAUTION Decal (hearing protection required)
3	CAUTION (hydraulic selector valve) Decal (vehicles equipped with self-recovery winch only)
4	"NO STEP" Stencil (multiple on exhaust and engine access panels)
5	"TIEDOWN" Stencil
6	WARNING (self-recovery winch) Plate (vehicles equipped with self-recovery winch only)
7	Self-Recovery Winch Data Plate

General - Continued

Table 5. M977A2 Cargo Passenger Side Exterior. - Continued

	(vehicles equipped with self-recovery winch only)
8	Outrigger Instruction Placard

Table 6. M977A2 Cargo Rear Exterior.

INDEX	PLATE/STENCIL
1	"SLING POINT" and "TIEDOWN" Stencils (one each per side)
2	US Army Star Stencil
3	On/Off Power Remote-Control Connector Data Plate
4	"DANGER" Plate (electrical warning)
5	Crane Range Diagram Plate

General - Continued***Table 7. M977A2 Miscellaneous Decals/Placards/Plates/Stencils.***

LOCATION	QUANTITY
Axle Housing	4
Carrier	4
Transfer Case	1
Engine	1
Transmission	1
Total	11

END OF WORK PACKAGE

CHAPTER 3
TROUBLESHOOTING
PROCEDURES

**OPERATOR MAINTENANCE
BUZZER SOUNDS AND AIR INDICATOR IS LIT**

INITIAL SETUP:**Equipment Condition**

Engine OFF. (WP 0057)

Equipment Condition - Continued

Parking brakes applied. (WP 0056)

Wheels chocked. (WP 0077)

TROUBLESHOOTING PROCEDURE**BUZZER SOUNDS AND AIR INDICATOR IS LIT****TEST 1 - Is air pressure greater than 75 psi (517 kPa)?**

1. Start engine, (WP 0044) and allow air pressure to build.
2. Check air pressure.

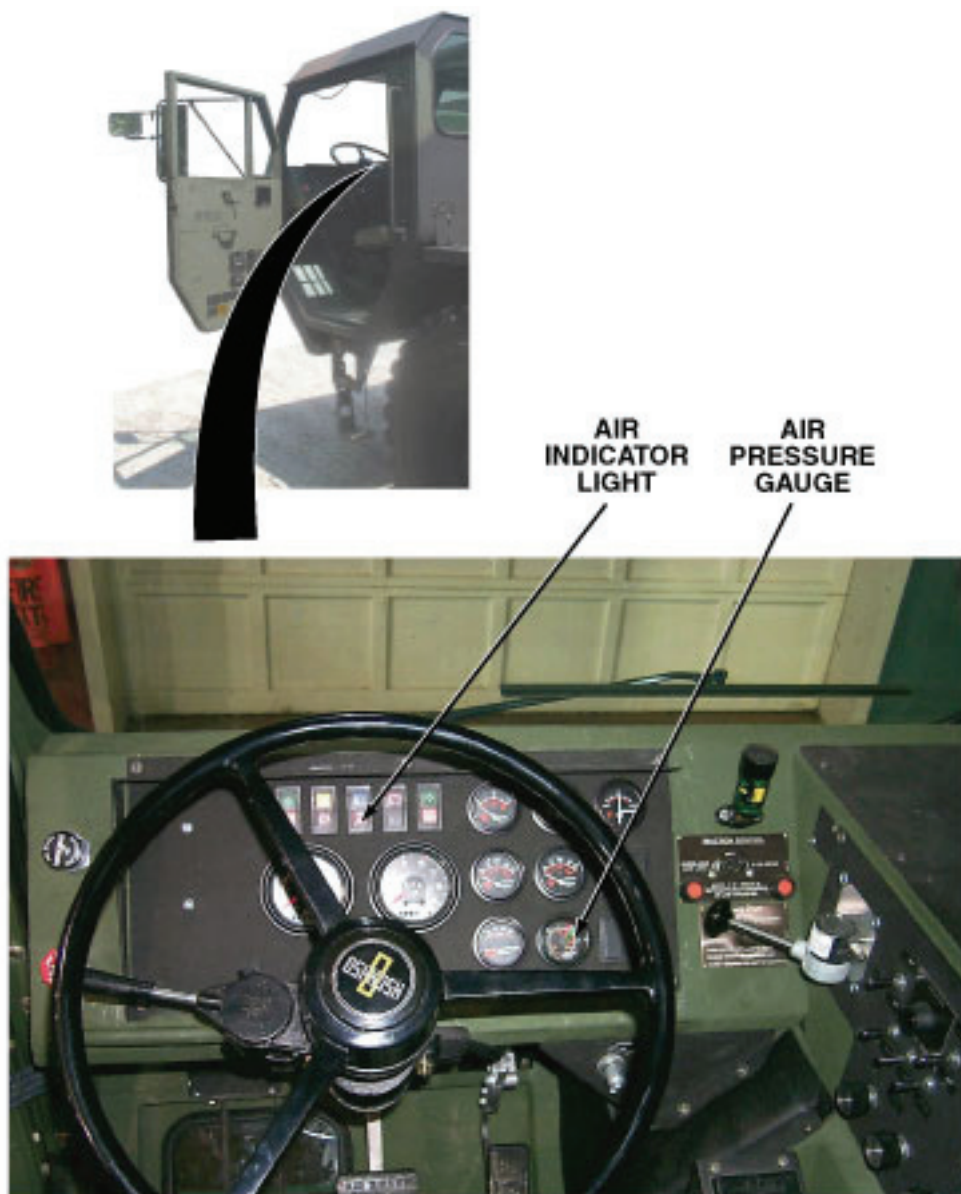

Figure 1.

3. Turn engine OFF. (WP 0057)

CONDITION/INDICATION

Is air pressure greater than 75 psi (517 kPa)?

DECISION

No - Test 2 - Are any petcock valves open?

Yes - Notify Supervisor.

TEST 2 - Are any petcock valves open?

1. Check if any air reservoir petcock valves are open. If valve(s) open, close petcock(s).

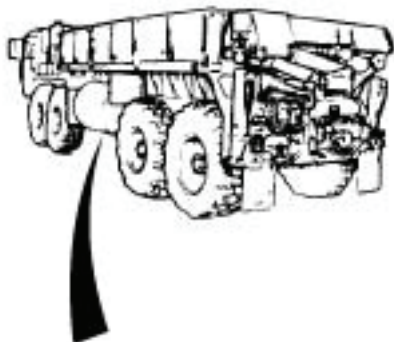

**AIR RESERVOIR NO. 2
(OTHERS SIMILAR)**

**PETCOCK
VALVE**

Figure 2.

CONDITION/INDICATION

Are any petcock valves open?

DECISION

Petcock(s) open - Test 6 - Does buzzer stop, and air indicator light extinguish?

Petcock's closed - Test 3 - Is trailer air supply control in correct position?

TEST 3 - Is trailer air supply control in correct position?

1. Check that trailer air supply control is pulled out (OFF position) if no trailer is coupled, and pushed in (ON position) if trailer is coupled.
2. If trailer air control is found in an incorrect position, set to correct position.



Figure 3.

CONDITION/INDICATION

Is trailer air supply control in correct position?

DECISION

No - Test 6 - Does buzzer stop, and air indicator light extinguish?

Yes - Test 4 - Does air reservoir, hoses, lines, fittings, and/or connectors leak?

TEST 4 - Does air reservoir, hoses, lines, fittings, and/or connectors leak?

1. Check air reservoir, hoses, lines, fittings, and/or connectors for leaks. Tighten any leaks found.

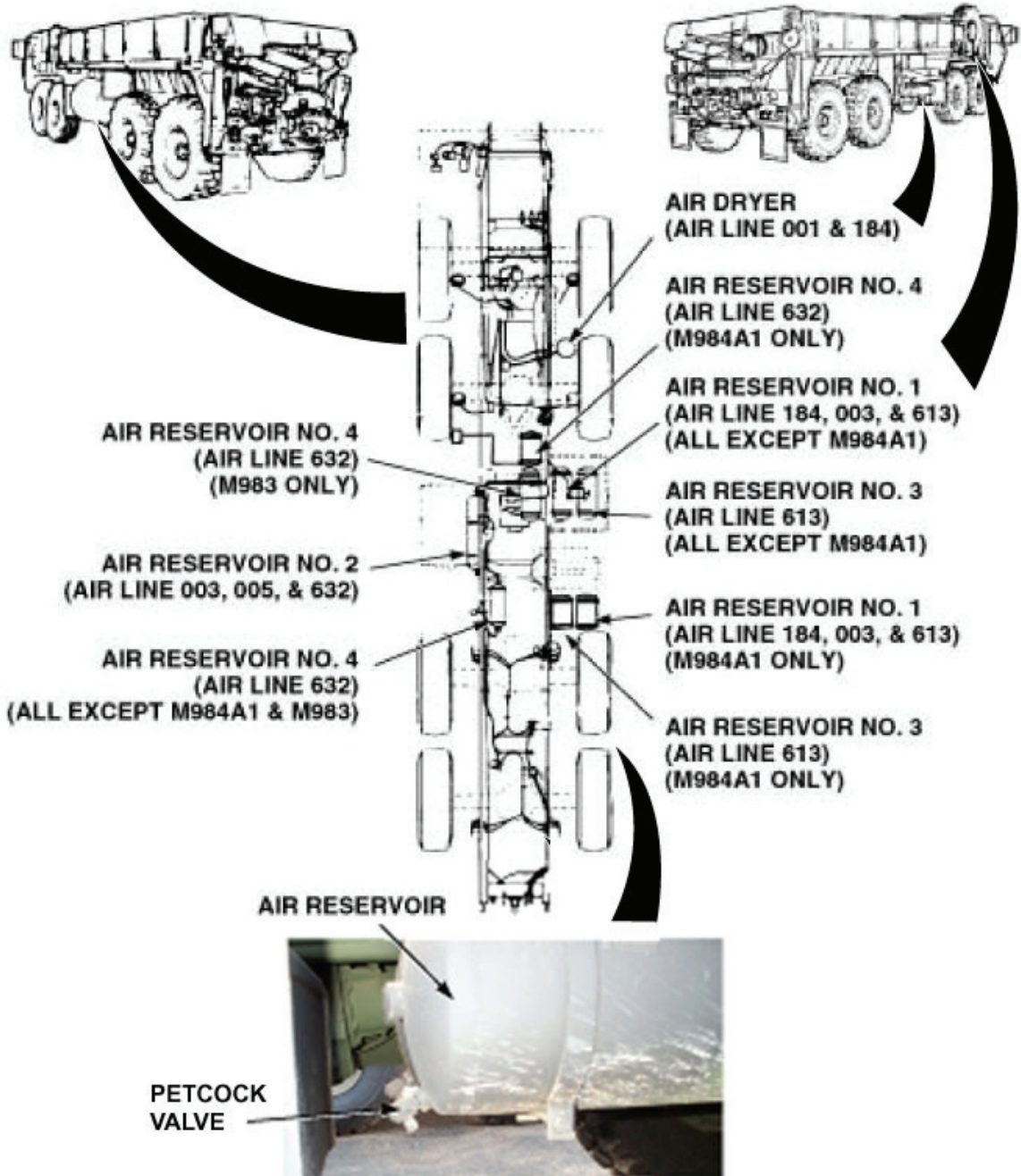

Figure 4.

CONDITION/INDICATION

Does air reservoir, hoses, lines, fittings, and/or connectors leak?

DECISION

Air reservoir, hoses, lines and/or connectors leak. - Notify Supervisor. Test 6 - Does buzzer stop, and air indicator light extinguish? Notify Supervisor.

Air reservoir, hoses, lines, fittings, and/or connectors OK - Test 5 - Does buzzer sound, and air indicator light illuminate when trailer is disconnected?

TEST 5 - Does buzzer sound, and air indicator light illuminate when trailer is disconnected?

1. If trailer is coupled, disconnect trailer (WP 0040) from vehicle.

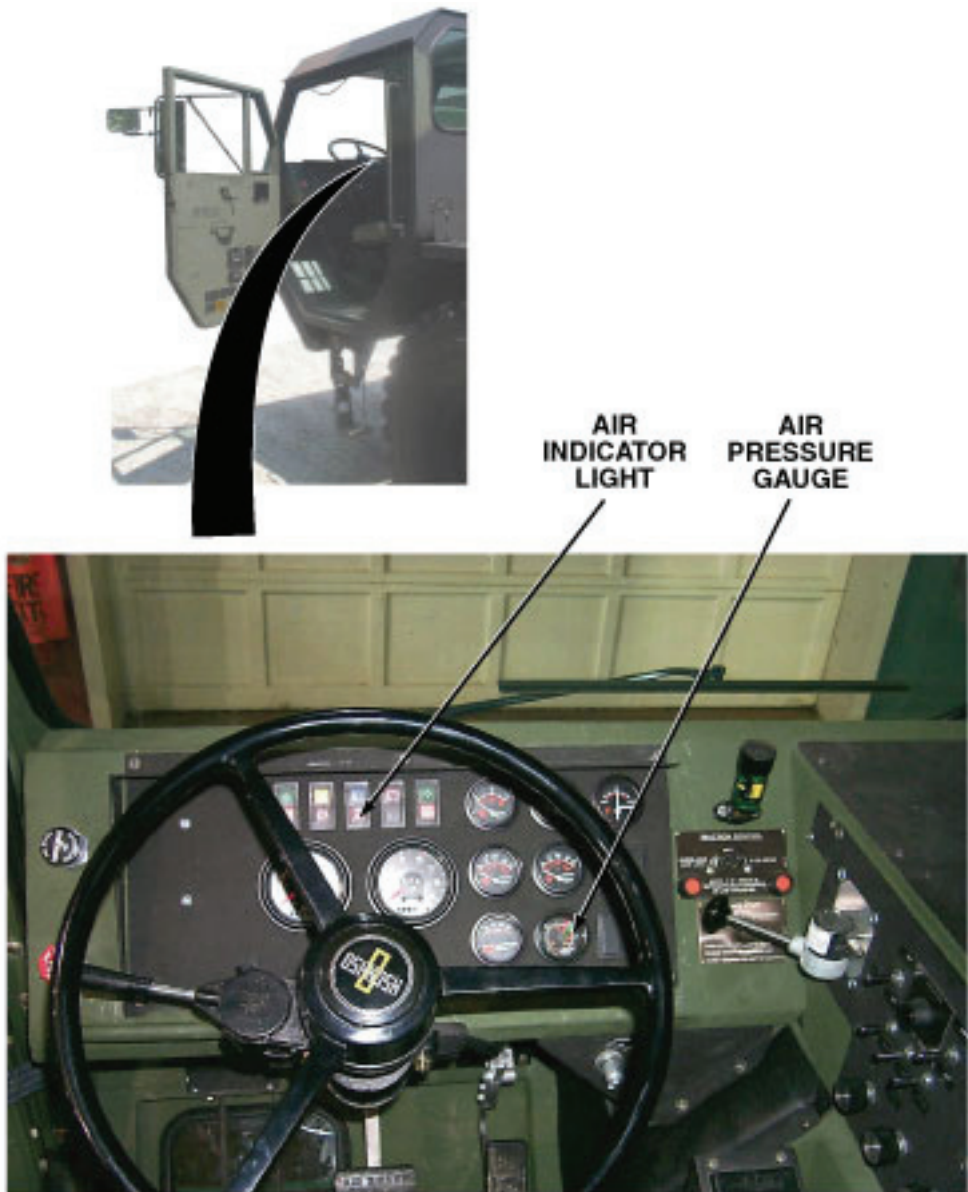

Figure 5.

2. Start engine, (WP 0044) and allow air pressure to build.
3. Check if buzzer continues to sound, and if air indicator light is illuminated.
4. Turn engine off. (WP 0057)

CONDITION/INDICATION

Does buzzer sound, and air indicator light illuminate when trailer is disconnected?

DECISION

No - Notify Supervisor.

Yes - Problem corrected.

TEST 6 - Does buzzer stop, and air indicator light extinguish?

1. Start engine, (WP 0044) and allow air pressure to build.
2. Check that buzzer does not sound, and air indicator light is off.

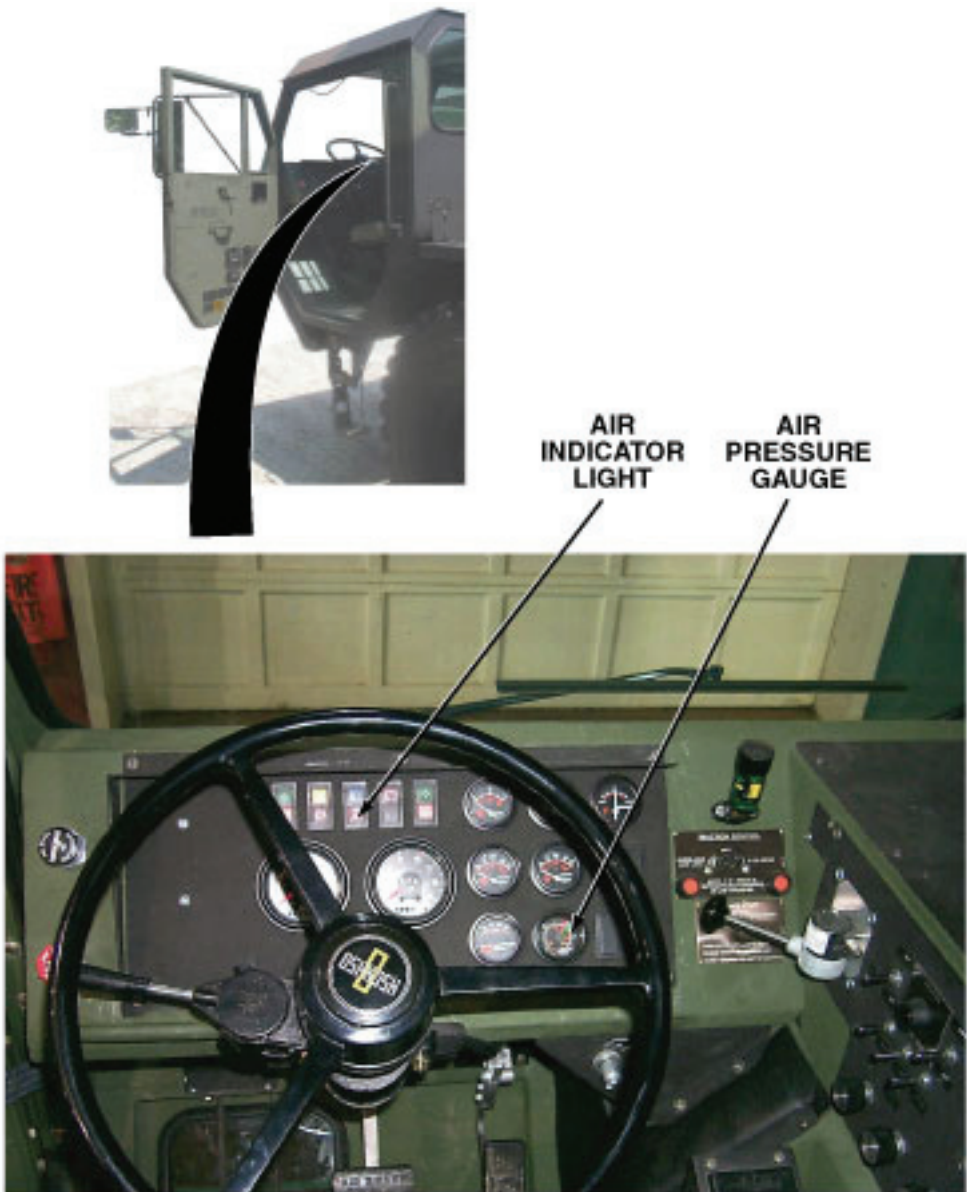

Figure 6.

3. Turn engine off. (WP 0057)

CONDITION/INDICATION

Does buzzer stop, and air indicator light extinguish?

DECISION

No - Notify Supervisor.

Yes - Problem corrected.

END OF WORK PACKAGE

**OPERATOR MAINTENANCE
WINDSHIELD WASHER WILL NOT OPERATE**

INITIAL SETUP:**Equipment Condition**

Engine OFF. (WP 0057)

Equipment Condition - Continued

Parking brakes applied. (WP 0056)

Wheels chocked. (WP 0077)

**TROUBLESHOOTING PROCEDURE
WINDSHIELD WASHER WILL NOT OPERATE**

TEST 1 - Is washer fluid reservoir free from damage or cracks?

1. Check washer fluid reservoir for cracks and/or damage.



Figure 1.

CONDITION/INDICATION

Is washer fluid reservoir free from damage or cracks?

DECISION

No - Notify Supervisor.

Yes - Test 2 - Is washer fluid present in washer fluid reservoir?

TEST 2 - Is washer fluid present in washer fluid reservoir?**CAUTION**

Do not fill windshield washer reservoir with water when temperatures are likely to be 32°F (0°C) or less. If water freezes, reservoir can crack or break.

1. Check washer fluid level in reservoir. if low, fill windshield washer reservoir.



Figure 2.

CONDITION/INDICATION

Is washer fluid present in washer fluid reservoir?

DECISION

No - Test 6 - Does the windshield washer operate?

Yes - Test 3 - Are all hoses securely attached to reservoir?

TEST 3 - Are all hoses securely attached to reservoir?

1. Check that all hoses are securely attached to reservoir. If loose hoses are found, attach to reservoir.

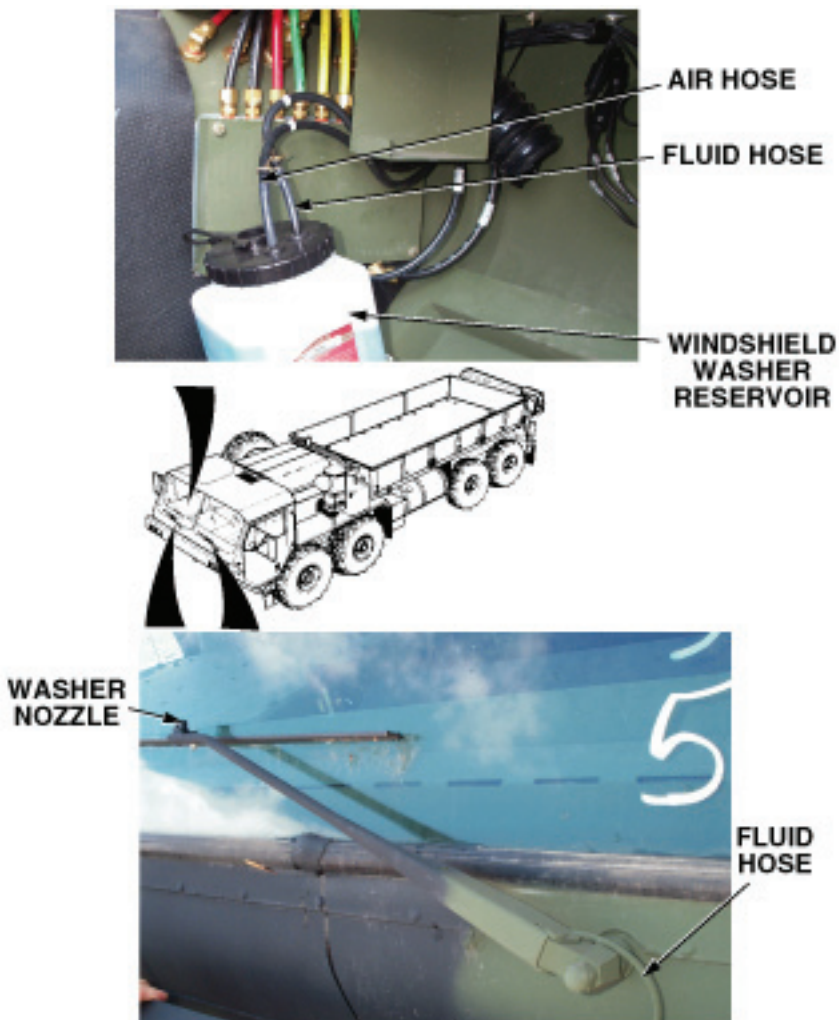

Figure 3.

CONDITION/INDICATION

Are all hoses securely attached to reservoir?

DECISION

No - Test 6 - Does the windshield washer operate?

Yes - Test 4 - Are hoses free of cracks or damage?

TEST 4 - Are hoses free of cracks or damage?

1. Check if hoses are cracked or damaged.

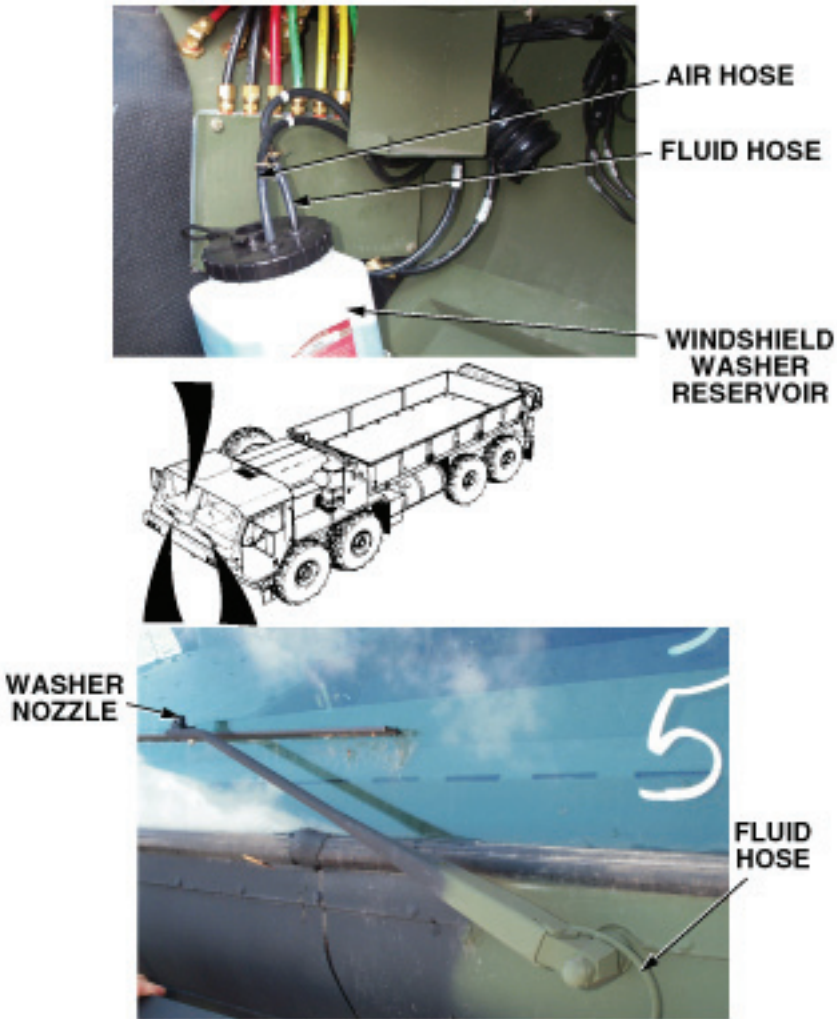

Figure 4.

CONDITION/INDICATION

Are hoses free of cracks or damage?

DECISION

No - Notify Supervisor.

Yes - Test 5 - Are washer spray openings free of debris?

TEST 5 - Are washer spray openings free of debris?

1. Check washer spray openings on wipers for clogs.

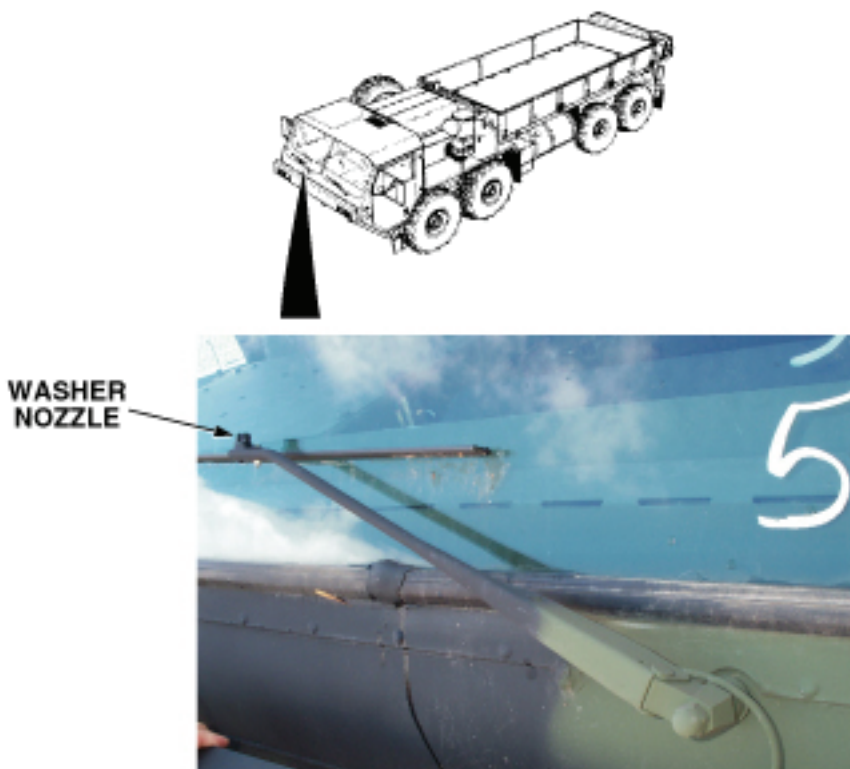

Figure 5.

2. If openings are clogged, clear washer spray opening using pin, wire, or similar item.

CONDITION/INDICATION

Are washer spray openings free of debris?

DECISION

No - Test 6 - Does the windshield washer operate?
Yes - Notify Supervisor.

TEST 6 - Does the windshield washer operate?

1. Start engine, (WP 0044) and allow air pressure to build.
2. Check windshield washer for proper operation.

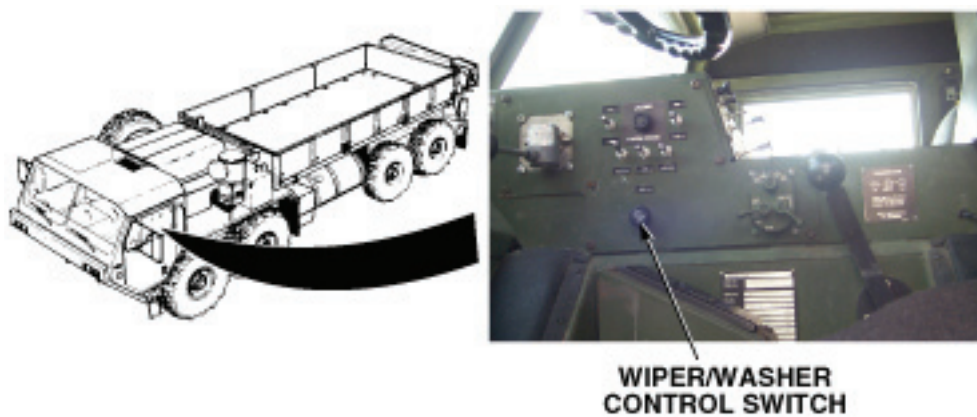

Figure 6.

CONDITION/INDICATION

Does the windshield washer operate?

DECISION

No - Notify Supervisor.

Yes - Problem corrected.

END OF WORK PACKAGE

**OPERATOR MAINTENANCE
AIR SYSTEM LOSES PRESSURE DURING OPERATION**

INITIAL SETUP:**Equipment Condition**

Engine OFF. (WP 0057)

Equipment Condition - Continued

Parking brakes applied. (WP 0056)

Wheels chocked. (WP 0077)

**TROUBLESHOOTING PROCEDURE
AIR SYSTEM LOSES PRESSURE DURING OPERATION**

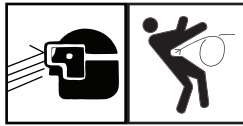
TEST 1 - Are any petcock valves open?**WARNING**

Vehicles air system is pressurized, be sure to wear proper eye protection and keep face away from drain valves while draining air reservoirs. Open air drain valves slowly to prevent sudden blast of air. Failure to comply may result in injury to personnel.

1. Check to make sure all four air reservoir petcock valves are closed.

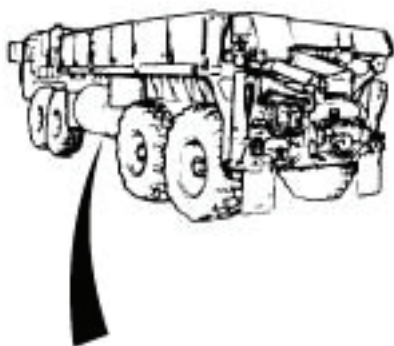

AIR RESERVOIR NO. 2
(OTHERS SIMILAR)

PETCOCK
VALVE

Figure 1.

CONDITION/INDICATION

Are any petcock valves open?

DECISION

Petcock(s) open - Test 5 - Does air system lose pressure during operation?
Petcocks closed - Test 2 - Is trailer air supply control in correct position?

TEST 2 - Is trailer air supply control in correct position?

1. Check if trailer air supply control is pulled out (OFF position) if no trailer is coupled, and pushed in (ON position) if trailer is coupled.

2. If trailer air supply control is found in an incorrect position, set to correct position.



Figure 2.

CONDITION/INDICATION

Is trailer air supply control in correct position?

DECISION

No - Test 5 - Does air system lose pressure during operation?

Yes - Test 3 - Does air pressure reach 120 psi (827 kPa) with engine accelerated?

TEST 3 - Does air pressure reach 120 psi (827 kPa) with engine accelerated?

1. Start engine. (WP 0044)
2. Accelerate engine and check if air pressure reaches 120 psi (827 kPa).

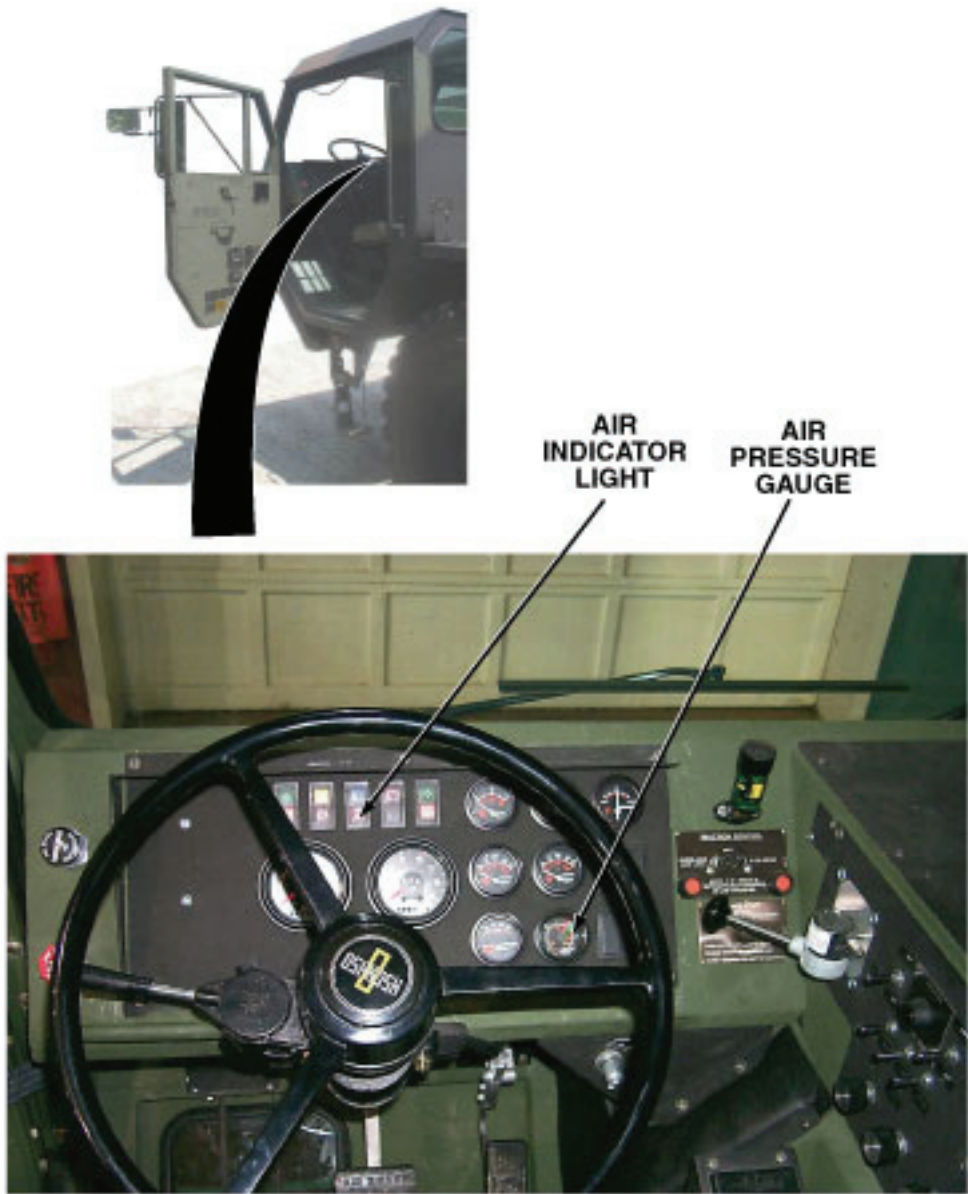

Figure 3.

CONDITION/INDICATION

Does air pressure reach 120 psi (827 kPa) with engine accelerated?

DECISION

No - Notify Supervisor.

Yes - Test 4 - Are air leaks present?

TEST 4 - Are air leaks present?

1. Turn engine off. (WP 0057)
2. Press service brake treadle completely down, and have crew member check for air leaks.

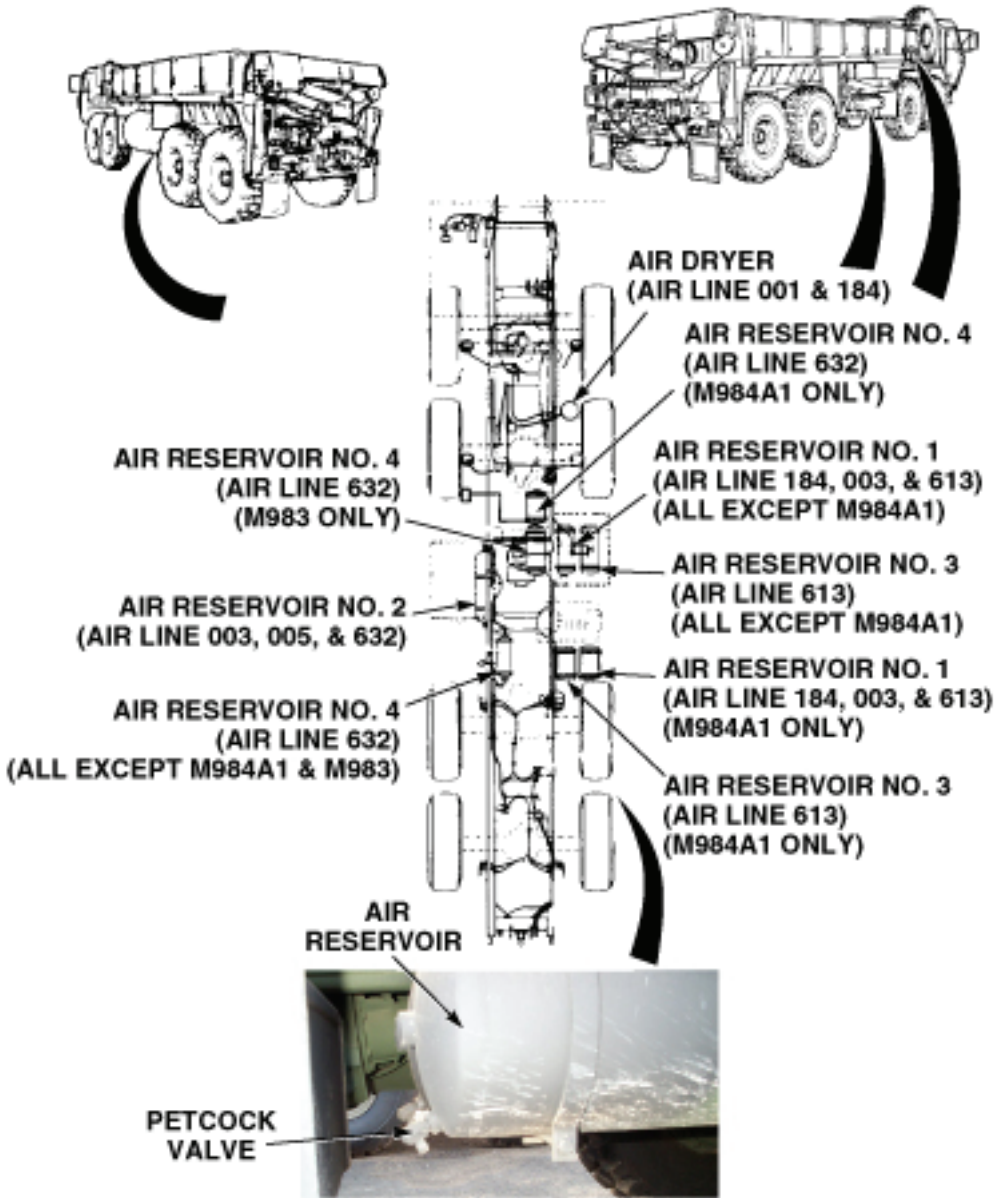

Figure 4.

3. If leaky fitting(s) found, tighten fittings.

CONDITION/INDICATION

Are air leaks present?

DECISION

Air leaks found - Notify Supervisor.

No air leaks found - Test 5 - Does air system lose pressure during operation?

TEST 5 - Does air system lose pressure during operation?

1. Start engine. (WP 0044)
2. Test drive vehicle.
3. Observe and note air pressure.

CONDITION/INDICATION

Does air system lose pressure during operation?

DECISION

No - Notify Supervisor.

Yes - Problem corrected.

END OF WORK PACKAGE

**OPERATOR MAINTENANCE
TRAILER BRAKE DOES NOT APPLY WHEN SERVICE BRAKE TREADLE OR
PARKING BRAKE IS USED**

INITIAL SETUP:**Equipment Condition**

Engine OFF. (WP 0057)

Equipment Condition - Continued

Parking brakes applied. (WP 0056)

Wheels chocked. (WP 0077)

TROUBLESHOOTING PROCEDURE**TRAILER BRAKE DOES NOT APPLY WHEN SERVICE BRAKE TREADLE OR
PARKING BRAKE IS USED****TEST 1 - Are intervehicular air hoses securely and correctly connected?**

1. Check that intervehicular air hoses are secure and correctly connected. If not, reconnect correctly.

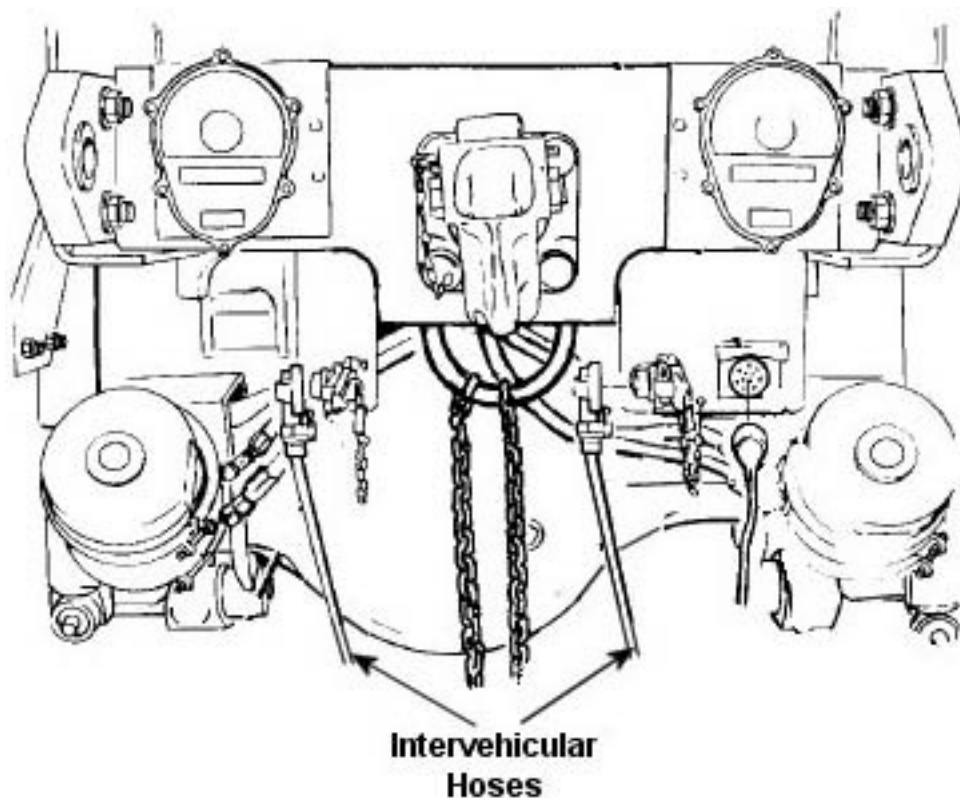

Figure 1.

CONDITION/INDICATION

Are intervehicular air hoses securely and correctly connected?

DECISION

No - Test 3 - Do trailer brakes apply when service brake treadle or parking brake is used?

Yes - Test 2 - Is trailer air supply control pushed in (ON position)?

TEST 2 - Is trailer air supply control pushed in (ON position)?

1. Check if trailer air supply control is pushed in (ON position).



Figure 2.

2. If trailer air supply control is found pulled out (OFF position), push in.

CONDITION/INDICATION

Is trailer air supply control pushed in (ON position)?

DECISION

No - Test 3 - Do trailer brakes apply when service brake treadle or parking brake is used?

Yes - Notify Supervisor.

TEST 3 - Do trailer brakes apply when service brake treadle or parking brake is used?

1. Start engine. (WP 0044)
2. Test drive vehicle.
3. Note trailer brake operations.

CONDITION/INDICATION

Do trailer brakes apply when service brake treadle or parking brake is used?

DECISION

No - Notify Supervisor.

Yes - Problem corrected.

END OF WORK PACKAGE

**OPERATOR MAINTENANCE
AIR HORN WILL NOT OPERATE**

INITIAL SETUP:

Equipment Condition

Engine OFF. (WP 0057)

Equipment Condition - Continued

Parking brakes applied. (WP 0056)

Wheels chocked. (WP 0077)

**TROUBLESHOOTING PROCEDURE
AIR HORN WILL NOT OPERATE**

TEST 1 - Are air hoses tight?

WARNING

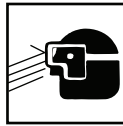

Caution the hose connections could be under pressure be sure to wear eye protection to avoid personal injury.

1. Check air hose connections for tightness. Tighten any loose hose connections found.

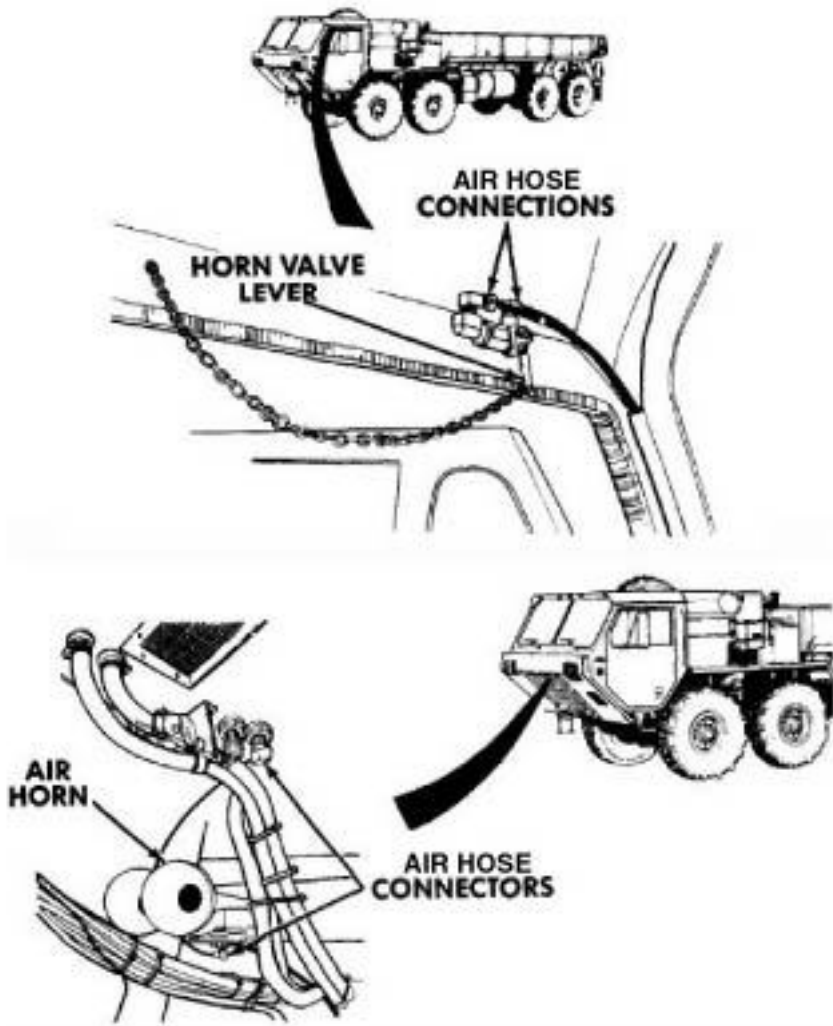

Figure 1.

CONDITION/INDICATION

Are air hoses tight?

DECISION

Connections loose - Test 3 - Does air horn operate?

Connections OK - Test 2 - Does horn valve lever move freely?

TEST 2 - Does horn valve lever move freely?

1. Check horn valve lever for freedom of movement.

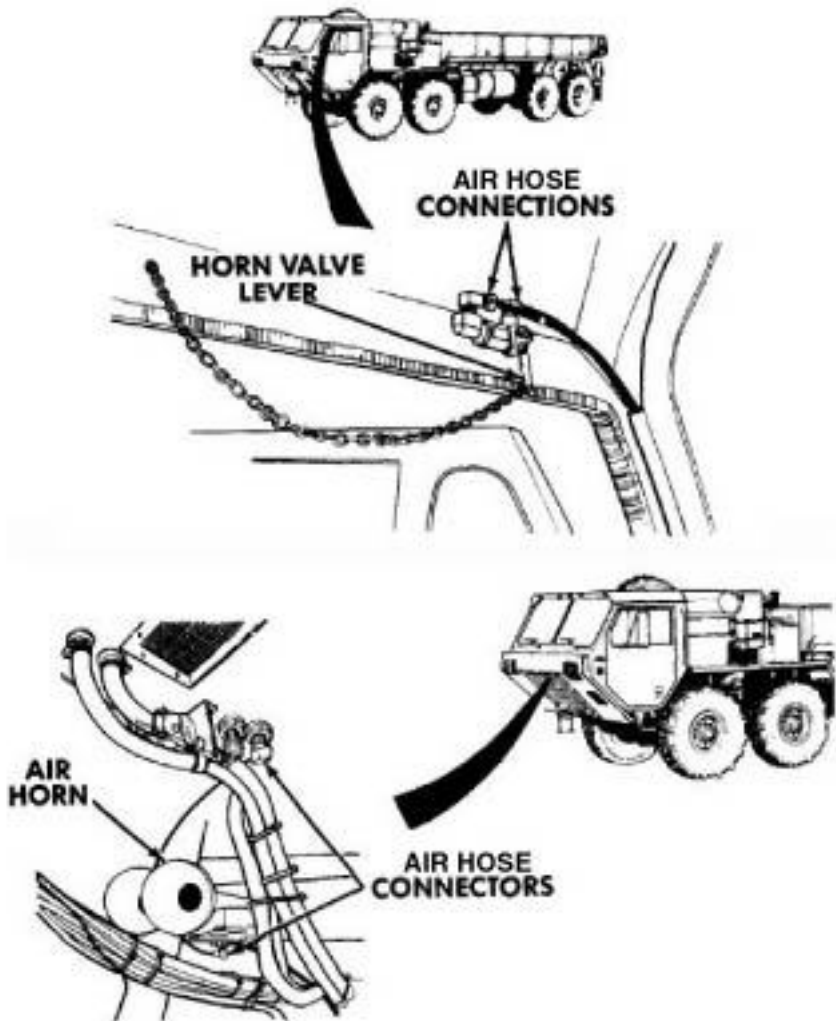

Figure 2.

CONDITION/INDICATION

Does horn valve lever move freely?

DECISION

No - Notify Supervisor.

Yes - Test 3 - Does air horn operate?

TEST 3 - Does air horn operate?

1. Start engine, (WP 0044) and allow air pressure to build.
2. Check air horn for proper operation.

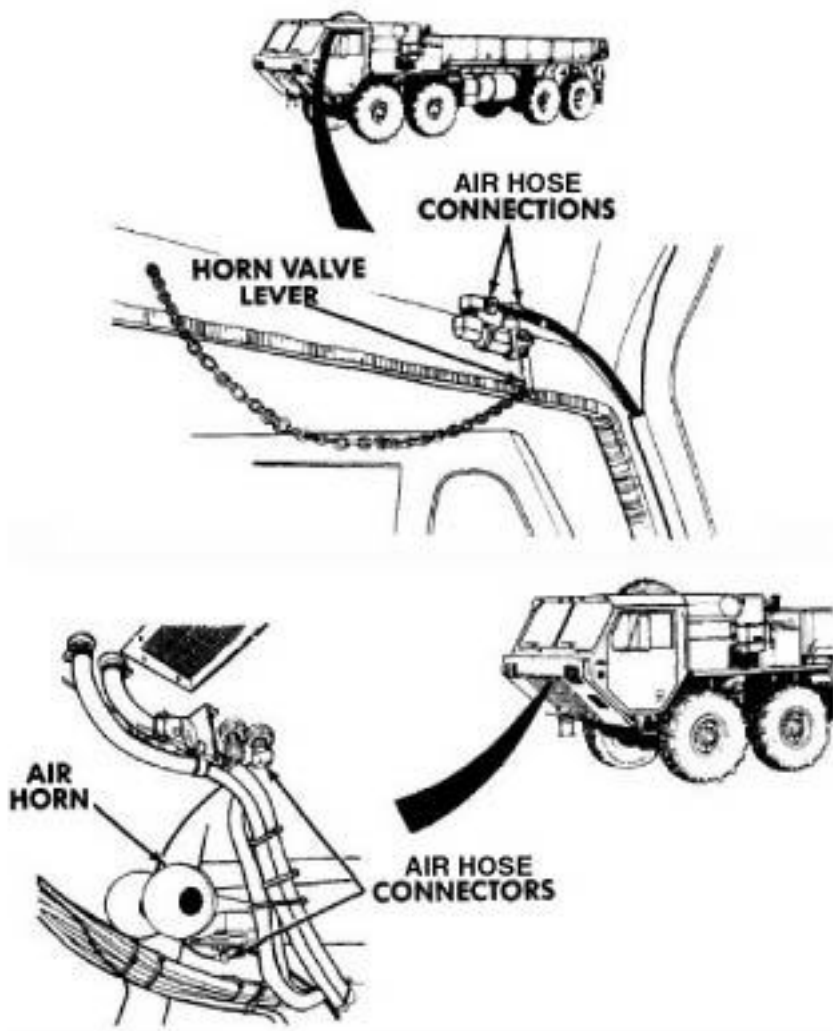

Figure 3.

3. Turn engine off. (WP 0057)

CONDITION/INDICATION

Does air horn operate?

DECISION

No - Notify Supervisor.

Yes - Problem corrected.

END OF WORK PACKAGE

**OPERATOR MAINTENANCE
ARCTIC ENGINE HEATER FAILS TO OPERATE**

INITIAL SETUP:**Equipment Condition**

Engine OFF. (WP 0057)

Equipment Condition - Continued

Parking brakes applied. (WP 0056)

Wheels chocked. (WP 0077)

**TROUBLESHOOTING PROCEDURE
ARCTIC ENGINE HEATER FAILS TO OPERATE**

TEST 1 - Is fuel present in fuel tank?

1. Turn engine start switch ON. (WP 0021)
2. Check fuel gauge for presence of fuel.



FUEL GAUGE

ENGINE
START SWITCH

Figure 1.

3. Turn engine start switch OFF.
4. Add fuel to fuel tank if no fuel present.

CONDITION/INDICATION

Is fuel present in fuel tank?

DECISION

No - Test 3 - Does arctic heater operate?

Yes - Test 2 - Are arctic heater intake port and exhaust tube free from blockage?

TEST 2 - Are arctic heater intake port and exhaust tube free from blockage?

1. Inspect arctic heater inlet port and exhaust tube for foreign objects and obstructions. Remove any items found.

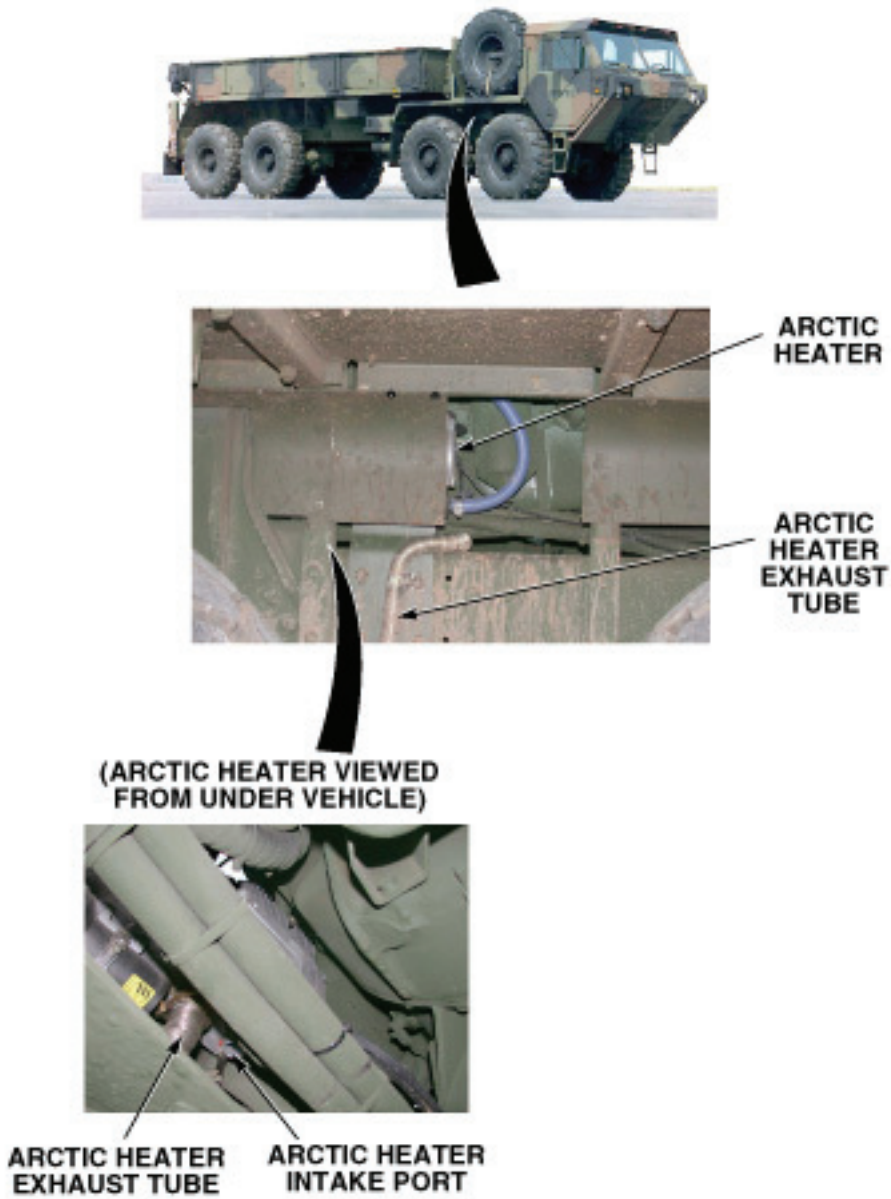

Figure 2.

CONDITION/INDICATION

Are arctic heater intake port and exhaust tube free from blockage?

DECISION

-
Continue - Test 3 - Does arctic heater operate?

TEST 3 - Does arctic heater operate?**CAUTION**

Do not attempt to operate arctic heater if arctic heater fails to start, or shutdown occurs during normal operation. System shutdown may indicate an arctic heater system fault. Failure to comply may cause system lockout.

CAUTION

Do not operate arctic heater if arctic heater indicator light flashes during normal operation. Arctic heater indicator light flashing indicates an arctic heater system fault. Failure to comply may cause system lockout.

NOTE

If arctic heater does not operate, arctic heater may be in lockout mode due to, either too many overheat occurrences (code 15), or too many start attempts (code 50). Arctic heater lockout mode (code 50) is activated if arctic heater fails to start after 20 successive start attempts (10 start cycles in succession).

NOTE

The arctic heater will attempt to start two times per start cycle. After the second failed start attempt, the arctic heater will not operate until the arctic heater on/off switch is turned off, then back on.

NOTE

Audible clicking from the arctic heater fuel metering pump may indicate that the arctic heater fuel system isn't primed. If audible clicking is heard from the arctic heater fuel metering pump, repeat steps (1) through (4) four times, or until arctic heater starts. Do not attempt to start arctic heater more than five times. The arctic heater should prime itself within nine start attempts.

1. Turn arctic heater ON. (WP 0058)
2. Observe arctic heater indicator light for steady illumination.
3. Observe arctic heater for proper operation.



Figure 3.

4. Turn arctic heater on/off switch OFF.

CONDITION/INDICATION

Does arctic heater operate?

DECISION

No - Notify Supervisor.

Yes - Problem corrected.

END OF WORK PACKAGE

OPERATOR MAINTENANCE ONE OR MORE LIGHTING CIRCUITS NOT OPERATING

INITIAL SETUP:

Equipment Condition

Engine OFF. (WP 0057)

Equipment Condition - Continued

Parking brakes applied. (WP 0056)

Wheels chocked. (WP 0077)

TROUBLESHOOTING PROCEDURE

ONE OR MORE LIGHTING CIRCUITS NOT OPERATING

TEST 1 - Is the lighting system control in the ON or OPERATING position?

1. Check if lighting system control is ON or in OPERATING position.

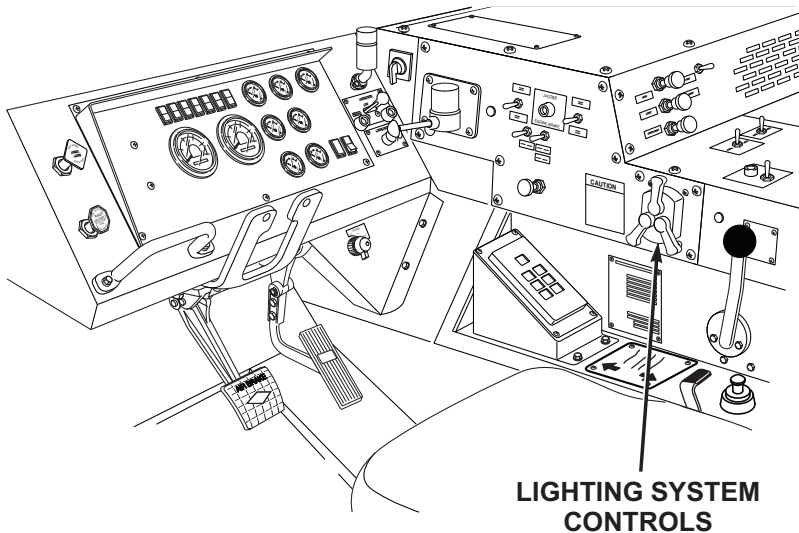

Figure 1.

CONDITION/INDICATION

Is the lighting system control in the ON or OPERATING position?

DECISION

No - Test 3 - Do all lighting circuits operate properly?

Yes - Test 2 - Is intervehicular connection secure and/or connected correctly?

TEST 2 - Is intervehicular connection secure and/or connected correctly?

1. If trailer is attached, and trailer lighting system is not working, check intervehicular connection. (WP 0040)
2. If trailer lights are the problem, make sure cable is securely connected.

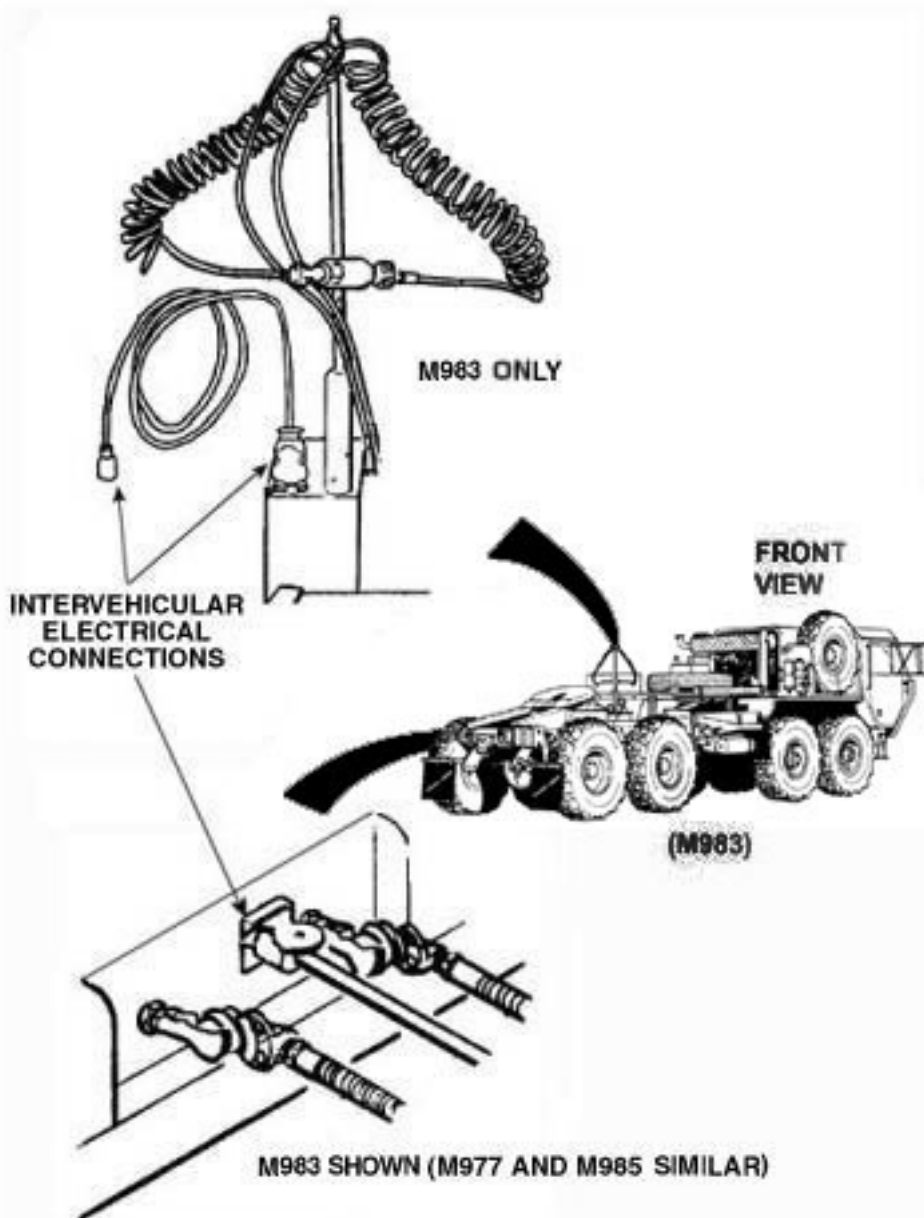

Figure 2.

CONDITION/INDICATION

Is intervehicular connection secure and/or connected correctly?

DECISION

Intervehicular cable loose. - Test 3 - Do all lighting circuits operate properly? Notify Supervisor.

Intervehicular connection OK. - Notify Supervisor.

TEST 3 - Do all lighting circuits operate properly?

1. Check for proper operation of dome lights. (WP 0066)
2. Check for proper operation of panel lights. (WP 0067)
3. Check for proper operation of service drive lights. (WP 0069)
4. Check for proper operation of parking lights. (WP 0068)
5. Check for proper operation of clearance lights. (WP 0071)
6. Check for proper operation of stoplight. (WP 0070)
7. Check for proper operation of blackout drive lights. (WP 0072)
8. Check for proper operation of blackout marker lights. (WP 0073)
9. Check for proper operation of turn signal lights. (WP 0075)

CONDITION/INDICATION

Do all lighting circuits operate properly?

DECISION

No - Notify Supervisor.

Yes - Problem corrected.

END OF WORK PACKAGE

OPERATOR MAINTENANCE
FAILS TO CRANK WHEN ENGINE START SWITCH IS TURNED TO START POSITION

INITIAL SETUP:

Equipment Condition

Engine OFF. (WP 0057)

Equipment Condition - Continued

Parking brakes applied. (WP 0056)

Wheels chocked. (WP 0077)

TROUBLESHOOTING PROCEDURE

FAILS TO CRANK WHEN ENGINE START SWITCH IS TURNED TO START POSITION

TEST 1 - Is transmission range selector in neutral (N)?

1. Verify range selector is in neutral (N) position. If not in neutral (N), shift it to neutral (N).

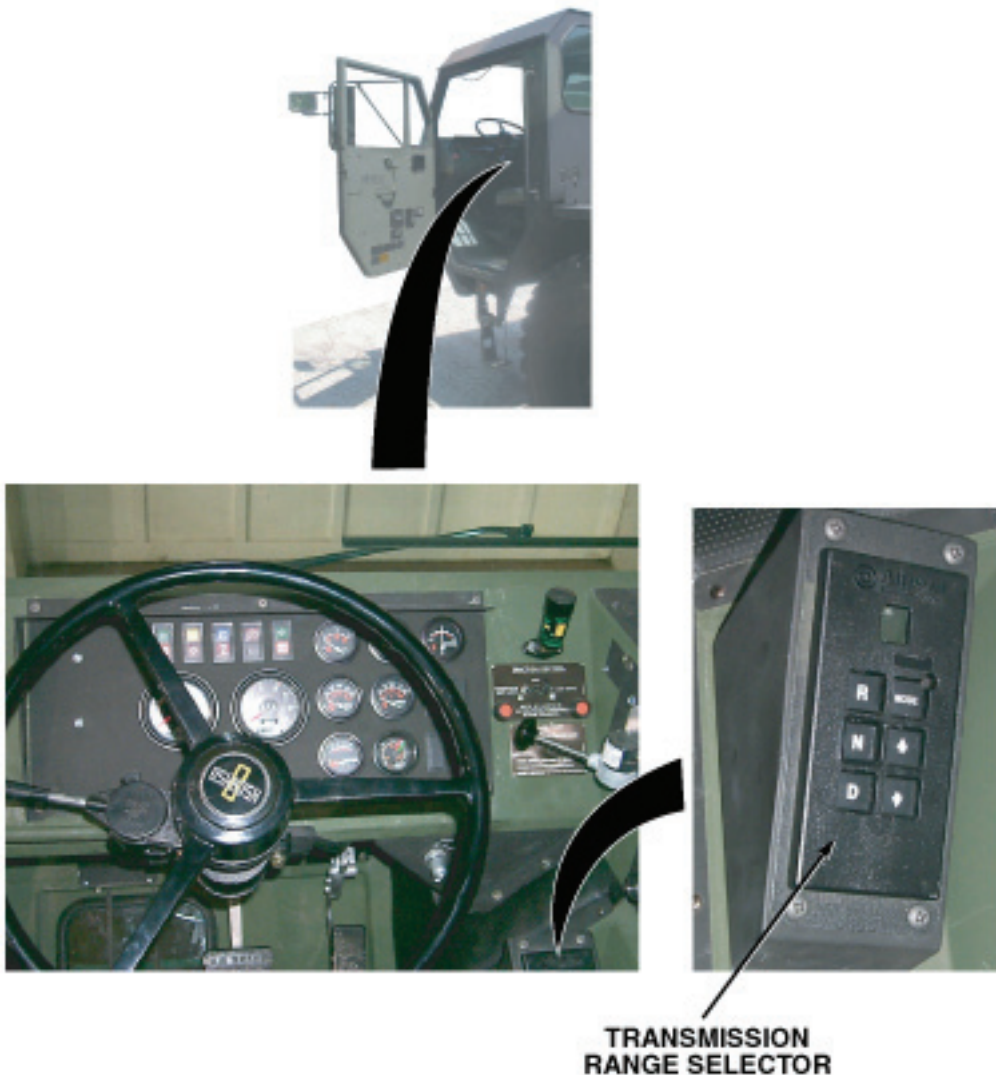

Figure 1.

CONDITION/INDICATION

Is transmission range selector in neutral (N)?

DECISION

No - Test 3 - Does engine crank when engine start switch is turned to start position?

Yes - Test 2 - Are battery cable connections clean, tight, and free from damage?

TEST 2 - Are battery cable connections clean, tight, and free from damage?

1. Remove battery box cover. (WP 0159)
2. Check battery cable connections for dirt, corrosion and/or looseness.

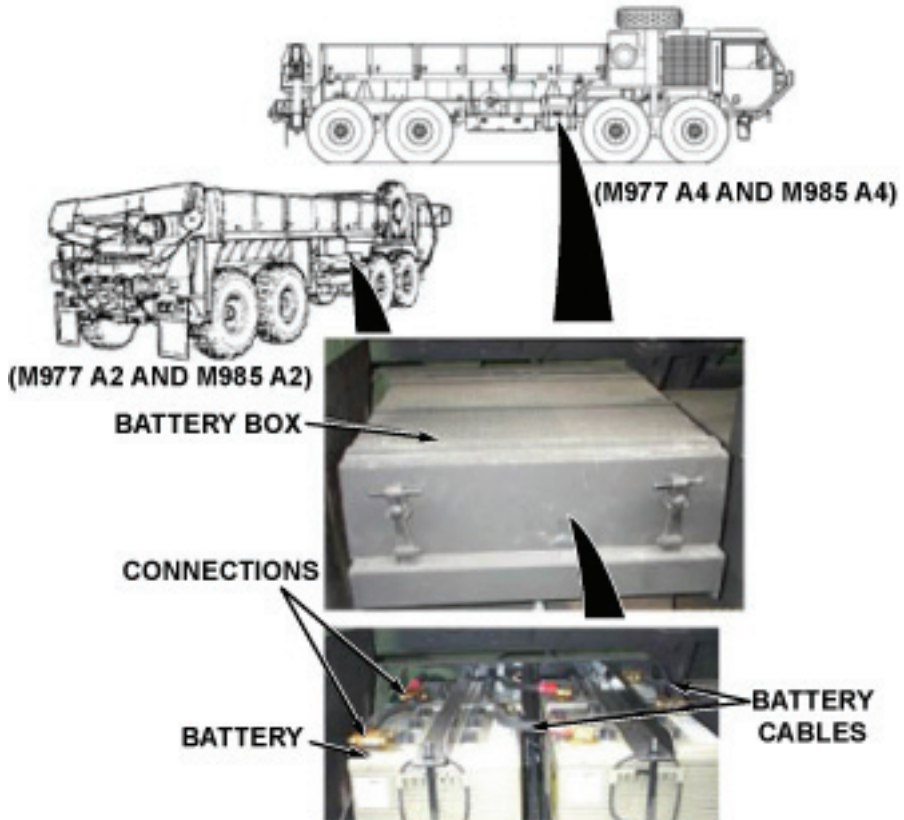
*Figure 2.*

3. Check battery cables for damage.

CONDITION/INDICATION

Are battery cable connections clean, tight, and free from damage?

DECISION

No - Notify Supervisor.

Yes - Test 3 - Does engine crank when engine start switch is turned to start position?

TEST 3 - Does engine crank when engine start switch is turned to start position?

1. Install battery box cover. (WP 0159)
2. Attempt to start engine. (WP 0044)

CONDITION/INDICATION

Does engine crank when engine start switch is turned to start position?

DECISION

No - Notify Supervisor.

Yes - Problem corrected.

END OF WORK PACKAGE

**OPERATOR MAINTENANCE
CRANKS BUT FAILS TO START**

INITIAL SETUP:**Equipment Condition**

Engine OFF. (WP 0057)

Equipment Condition - Continued

Parking brakes applied. (WP 0056)

Wheels chocked. (WP 0077)

**TROUBLESHOOTING PROCEDURE
CRANKS BUT FAILS TO START**

TEST 1 - Does fuel gauge indicate the presence of fuel?

1. Turn engine start switch ON. (WP 0021)
2. Check fuel gauge for indication of fuel presence.



FUEL GAUGE

Figure 1.

3. Turn engine start switch OFF. (WP 0021)
4. If fuel gauge indicated no fuel present, add fuel to fuel tank.

CONDITION/INDICATION

Does fuel gauge indicate the presence of fuel?

DECISION

No - Test 5 - Does engine start?

Yes - Test 2 - Is there fuel present in fuel tank?

TEST 2 - Is there fuel present in fuel tank?

1. Remove fuel tank cap and filter screen from fuel tank.

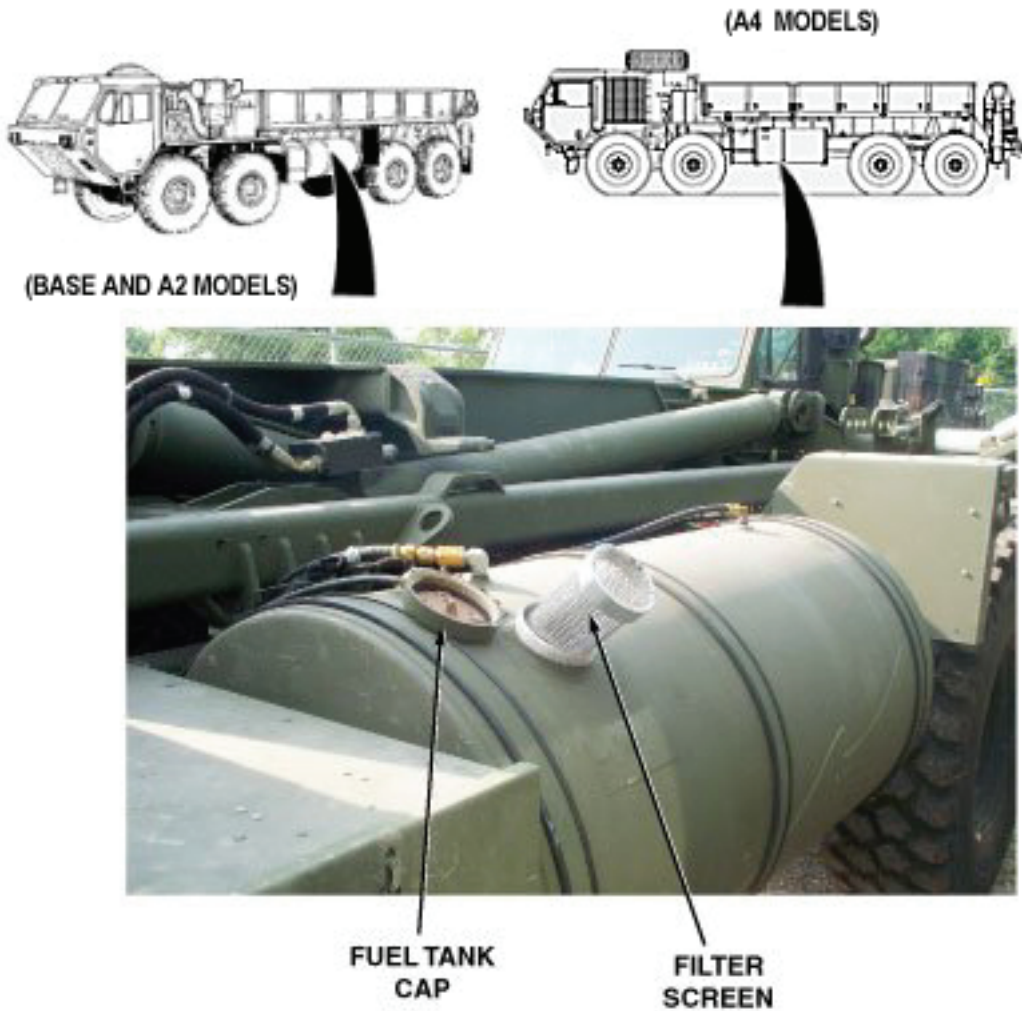

Figure 2.

2. Check fuel tank for presence of fuel.
3. Add fuel to fuel tank if no fuel was present.
4. Replace filter screen and fuel tank cap on fuel tank.

CONDITION/INDICATION

Is there fuel present in fuel tank?

DECISION

- No - Test 5 - Does engine start?
- Yes - Test 3 - Is air filter restricted?

TEST 3 - Is air filter restricted?

1. Attempt to start engine and note indication on air filter restriction indicator.



**AIR FILTER
RESTRICTION INDICATOR**

Figure 3.

CONDITION/INDICATION

Is air filter restricted?

DECISION

Restricted -

Not Restricted - Test 5 - Does engine start?

TEST 4 - Does air filter restriction indicator showed yellow and/or VACUUM INCHES H2O window shows less than 18 after servicing air filter??

1. Service air filter. (WP 0157)
2. Attempt to start engine and note indication on air filter restriction indicator.



**AIR FILTER
RESTRICTION INDICATOR**

Figure 4.

CONDITION/INDICATION

Does air filter restriction indicator showed yellow and/or VACUUM INCHES H₂O window shows less than 18 after servicing air filter??

DECISION

Restricted - Notify Supervisor.

Not Restricted - Test 5 - Does engine start?

TEST 5 - Does engine start?

1. Attempt to start engine. (WP 0044)

CONDITION/INDICATION

Does engine start?

DECISION

No. - Notify Supervisor.

Yes. - Problem corrected.

END OF WORK PACKAGE

OPERATOR MAINTENANCE
STARTS OR RUNS ROUGHLY AFTER PROPER WARM-UP, DOES NOT MAKE FULL
POWER, OR MAKES EXCESSIVE EXHAUST SMOKE

INITIAL SETUP:

Equipment Condition

Engine OFF. (WP 0057)

Equipment Condition - Continued

Parking brakes applied. (WP 0056)

Wheels chocked. (WP 0077)

TROUBLESHOOTING PROCEDURE

STARTS OR RUNS ROUGHLY AFTER PROPER WARM-UP, DOES NOT MAKE FULL
POWER, OR MAKES EXCESSIVE EXHAUST SMOKE

TEST 1 - Is PTO engaged?

1. Start engine and allow engine to reach normal operating temperature. (WP 0044)
2. Check PTO ENGAGE switch and PTO ENGAGE indicator to make sure that PTO is disengaged. Light should be off.

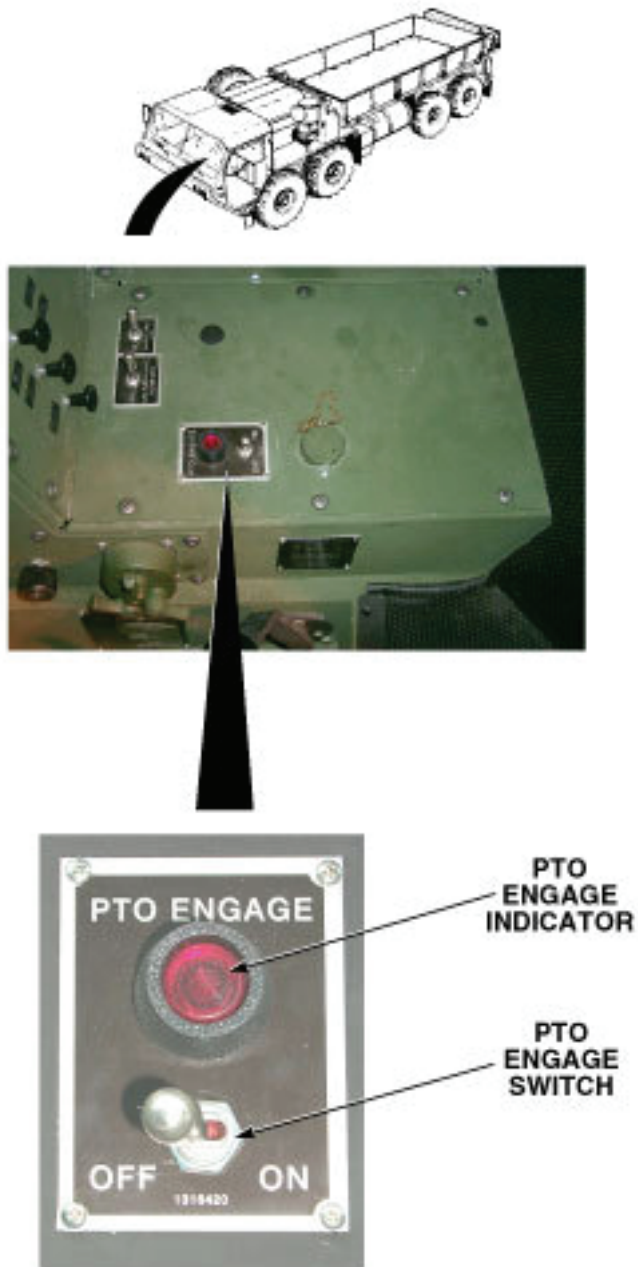

Figure 1.

CONDITION/INDICATION

Is PTO engaged?

DECISION

PTO engaged. - Test 4 - Does engine start or run roughly after proper warm-up, and/or does not make full power or makes excessive exhaust smoke?

PTO disengaged. - Test 2 - Does air filter restriction indicator show red and/or VACUUM INCHES H₂O window show 18 or more after being reset?

TEST 2 - Does air filter restriction indicator show red and/or VACUUM INCHES H₂O window show 18 or more after being reset?

1. Reset air filter restriction indicator.
2. Start engine. (WP 0044)
3. Check if air filter restriction indicator is red and/or VACUUM INCHES H₂O window shows 18 or more.



**AIR FILTER
RESTRICTION
INDICATOR**

Figure 2.

CONDITION/INDICATION

Does air filter restriction indicator show red and/or VACUUM INCHES H2O window show 18 or more after being reset?

DECISION

Restricted. - Test 3 - Does air filter restriction indicator show red and/or VACUUM INCHES H2O window show 18 or more after being cleaned?

Not restricted. - Test 4 - Does engine start or run roughly after proper warm-up, and/or does not make full power or makes excessive exhaust smoke?

TEST 3 - Does air filter restriction indicator show red and/or VACUUM INCHES H2O window show 18 or more after being cleaned?

1. Turn engine OFF. (WP 0057)
2. Clean air filter. (WP 0157)
3. Start engine. (WP 0044)
4. Check if air filter restriction indicator is red and/or VACUUM INCHES H2O window shows 18 or more.



**AIR FILTER
RESTRICTION
INDICATOR**

Figure 3.

CONDITION/INDICATION

Does air filter restriction indicator show red and/or VACUUM INCHES H2O window show 18 or more after being cleaned?

DECISION

Restricted. - Notify Supervisor.

Not restricted. - Test 4 - Does engine start or run roughly after proper warm-up, and/or does not make full power or makes excessive exhaust smoke?

TEST 4 - Does engine start or run roughly after proper warm-up, and/or does not make full power or makes excessive exhaust smoke?

1. Test drive vehicle.

CONDITION/INDICATION

Does engine start or run roughly after proper warm-up, and/or does not make full power or makes excessive exhaust smoke?

DECISION

Runs rough. - Notify Supervisor.

Runs normal. - Problem corrected.

END OF WORK PACKAGE

OPERATOR MAINTENANCE ENGINE OVERHEATS

INITIAL SETUP:

Equipment Condition

Engine OFF. (WP 0057)

Equipment Condition - Continued

Parking brakes applied. (WP 0056)

Wheels chocked. (WP 0077)

TROUBLESHOOTING PROCEDURE ENGINE OVERHEATS

TEST 1 - Are right-side radiator hoses and housing free from leaks?

WARNING



Radiator coolant hoses are very hot and pressurized during vehicle operation. Allow radiator to cool prior to checking hoses. Failure to comply may result in injury or death to personnel.

1. Open driver and passenger side engine covers. (WP 0160)
2. Check upper and lower radiator hoses and housing for leaks.
3. Check that all clamps are tight and secure.

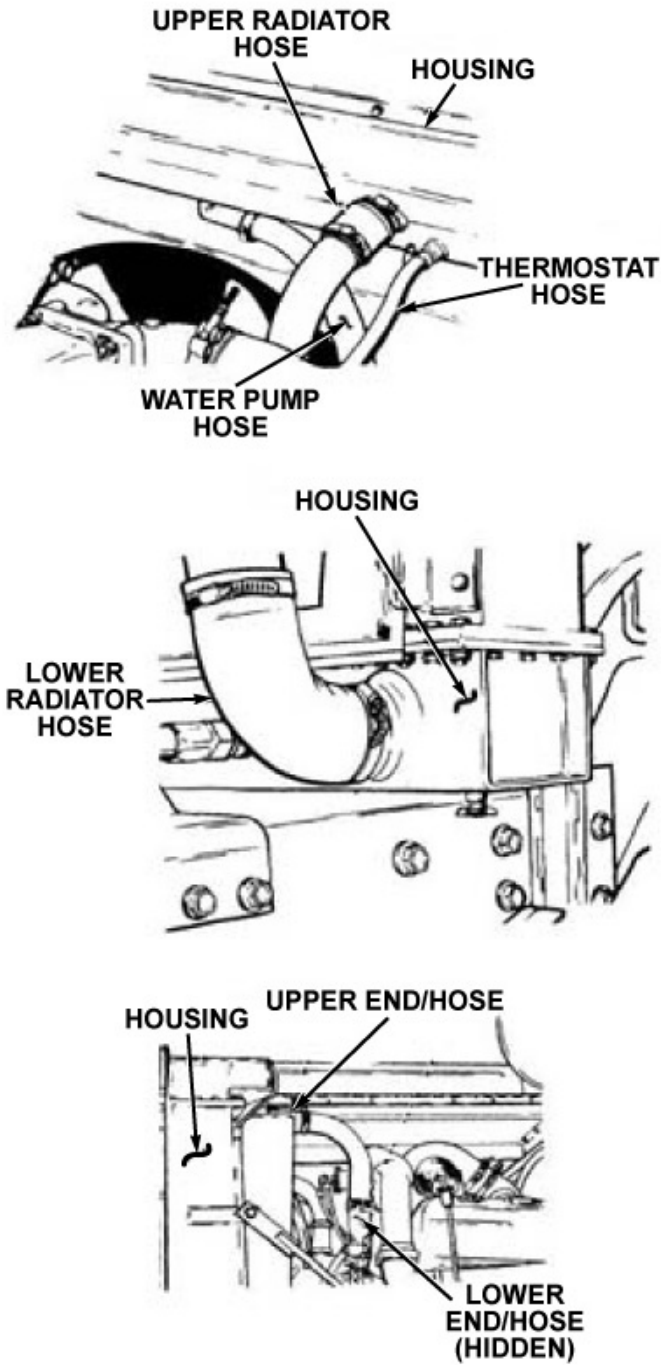

Figure 1.

CONDITION/INDICATION

Are right-side radiator hoses and housing free from leaks?

DECISION

Radiator hoses and/or housing damaged. - Notify Supervisor. Test 2 - Does engine overheat? Notify Supervisor.

Radiator hoses and/or housing free from damage and/or leaks. - Notify Supervisor.

TEST 2 - Does engine overheat?

1. Close driver and passenger side engine covers. (WP 0160)
2. Start engine. (WP 0044)

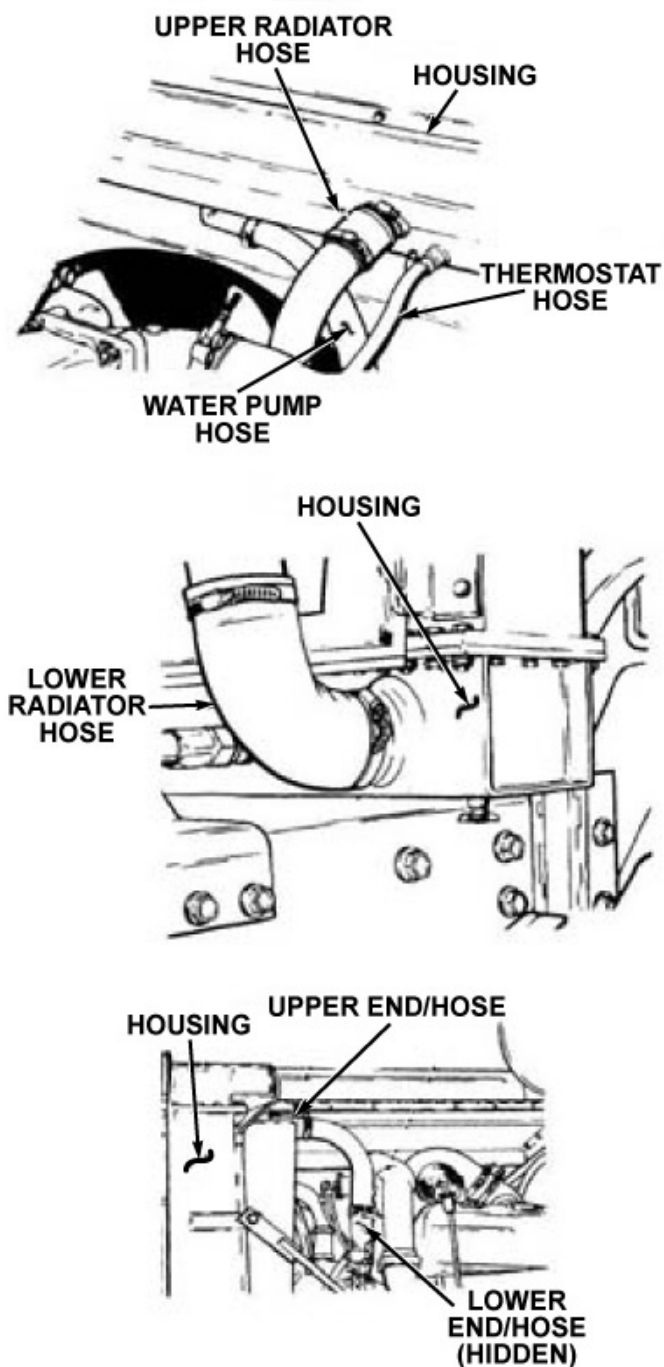

Figure 2.

3. Test drive vehicle.

CONDITION/INDICATION

Does engine overheat?

DECISION

Engine overheats - Notify Supervisor.

Engine OK - Problem corrected.

END OF WORK PACKAGE

**OPERATOR MAINTENANCE
LOW OIL PRESSURE GAUGE INDICATION**

INITIAL SETUP:**Equipment Condition**

Engine OFF. (WP 0057)

Equipment Condition - Continued

Parking brakes applied. (WP 0056)

Wheels chocked. (WP 0077)

**TROUBLESHOOTING PROCEDURE
LOW OIL PRESSURE GAUGE INDICATION**

TEST 1 - Is engine oil level low?

1. Check engine oil level. (WP 0147)

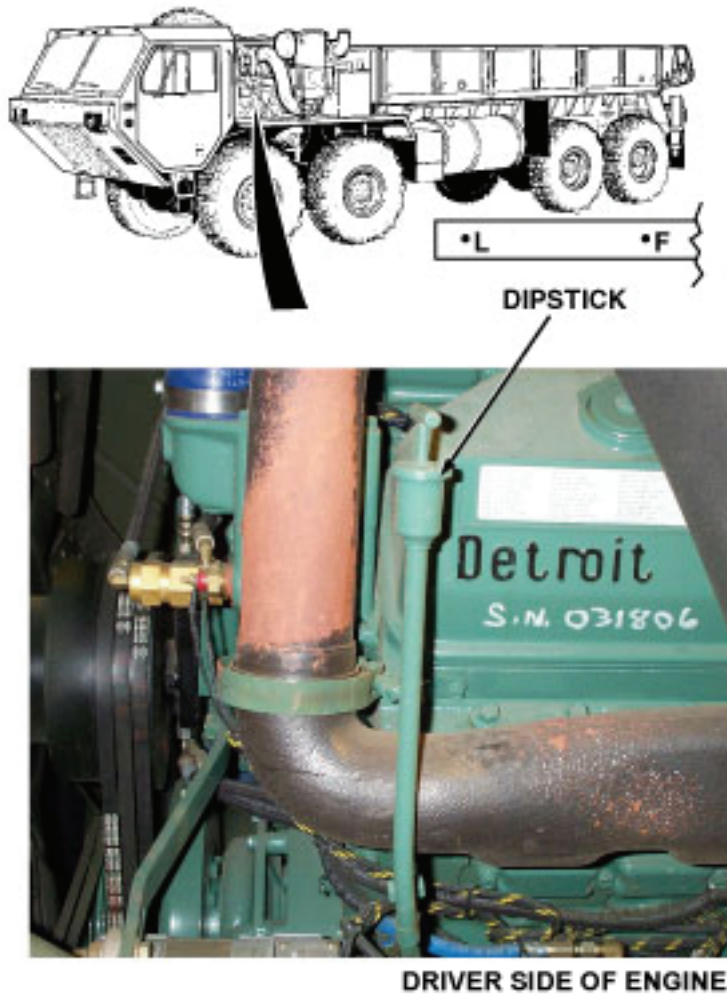

Figure 1.

2. If oil level is low, fill oil to proper level. (WP 0147)

CONDITION/INDICATION

Is engine oil level low?

DECISION

-

Continue - Test 2 - Is engine oil pressure still low?

TEST 2 - Is engine oil pressure still low?

1. Start engine and allow engine to reach operating temperature. (WP 0044)
2. Check OIL PRESS gauge. Gauge should read as follows:
 - At idle, oil pressure can go as low as 5 psi (34 kPa).
 - Normal operation range is 40 psi to 60 psi (276 to 414 kPa) between engine speeds 1800 to 2100 rpm. Minimum for safe operation is 30 psi (207 kPa).

CONDITION/INDICATION

Is engine oil pressure still low?

DECISION

Oil pressure low. - Notify Supervisor.

Oil pressure OK. - Problem corrected.

END OF WORK PACKAGE

**OPERATOR MAINTENANCE
EXCESSIVE OIL CONSUMPTION**

INITIAL SETUP:**Equipment Condition**

Engine OFF. (WP 0057)

Equipment Condition - Continued

Parking brakes applied. (WP 0056)

Wheels chocked. (WP 0077)

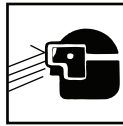
**TROUBLESHOOTING PROCEDURE
EXCESSIVE OIL CONSUMPTION****TEST 1 - Are engine oil lines loose?****WARNING**

Caution the oil lines could be under pressure be sure to wear the proper eye protection to avoid personal injury.

1. Open driver and passenger side engine covers. (WP 0160)

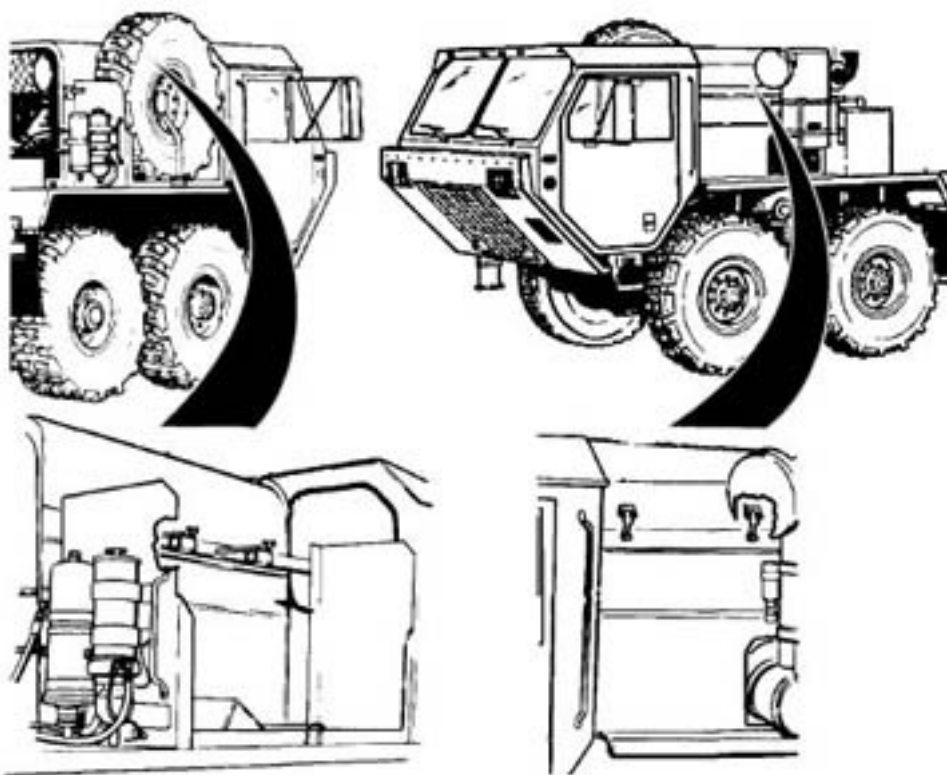

Figure 1.

2. Check for loose engine oil lines or damaged components.

CONDITION/INDICATION

Are engine oil lines loose?

DECISION

Lines Loose - Notify Supervisor.

Lines OK - Test 2 - Are any engine oil leaks present?

TEST 2 - Are any engine oil leaks present?

1. Tighten any loose fittings/components if found.
2. Visually check for engine oil leaks.

CONDITION/INDICATION

Are any engine oil leaks present?

DECISION

Leaks found. - Notify Supervisor.

No leaks found. - Notify Supervisor.

END OF WORK PACKAGE

OPERATOR MAINTENANCE
HYDRAULIC SYSTEM OPERATES TOO SLOW, TOO FAST, WITH JERKY
MOVEMENTS; OR ONE OR MORE HYDRAULICS CIRCUITS WILL NOT OPERATE

INITIAL SETUP:**Equipment Condition**

Engine OFF. (WP 0057)

Equipment Condition - Continued

Parking brakes applied. (WP 0056)

Wheels chocked. (WP 0077)

TROUBLESHOOTING PROCEDURE

HYDRAULIC SYSTEM OPERATES TOO SLOW, TOO FAST, WITH JERKY
MOVEMENTS; OR ONE OR MORE HYDRAULICS CIRCUITS WILL NOT OPERATE

TEST 1 - Is hydraulic fluid level within normal operating range?

1. Check hydraulic fluid level. If low, add hydraulic fluid. (WP 0147)

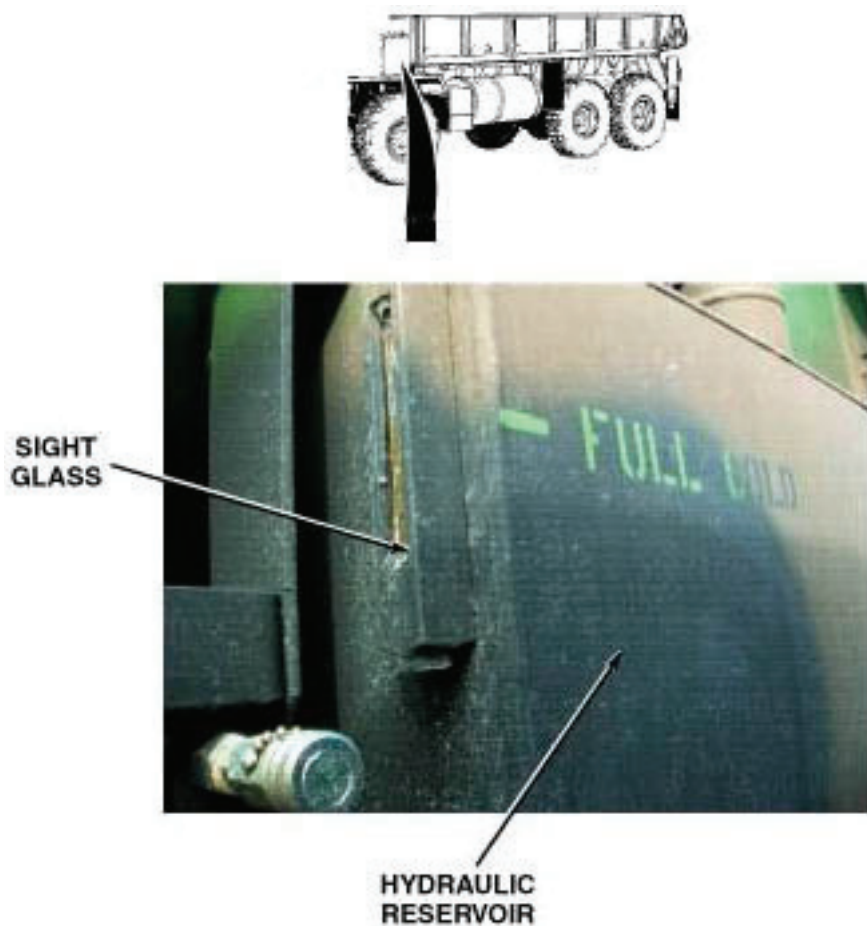

Figure 1.

CONDITION/INDICATION

Is hydraulic fluid level within normal operating range?

DECISION

No - Test 3 - Do all hydraulic systems operate properly?

Yes - Test 2 - Are hydraulic hoses and connections free from leaks and/or damage?

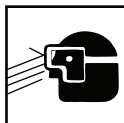
TEST 2 - Are hydraulic hoses and connections free from leaks and/or damage?**WARNING**

Caution the hydraulic system maybe under pressure be sure to wear the proper eye protection to avoid personal injury.

1. Check hydraulic hoses and connections for leaks and/or damage.

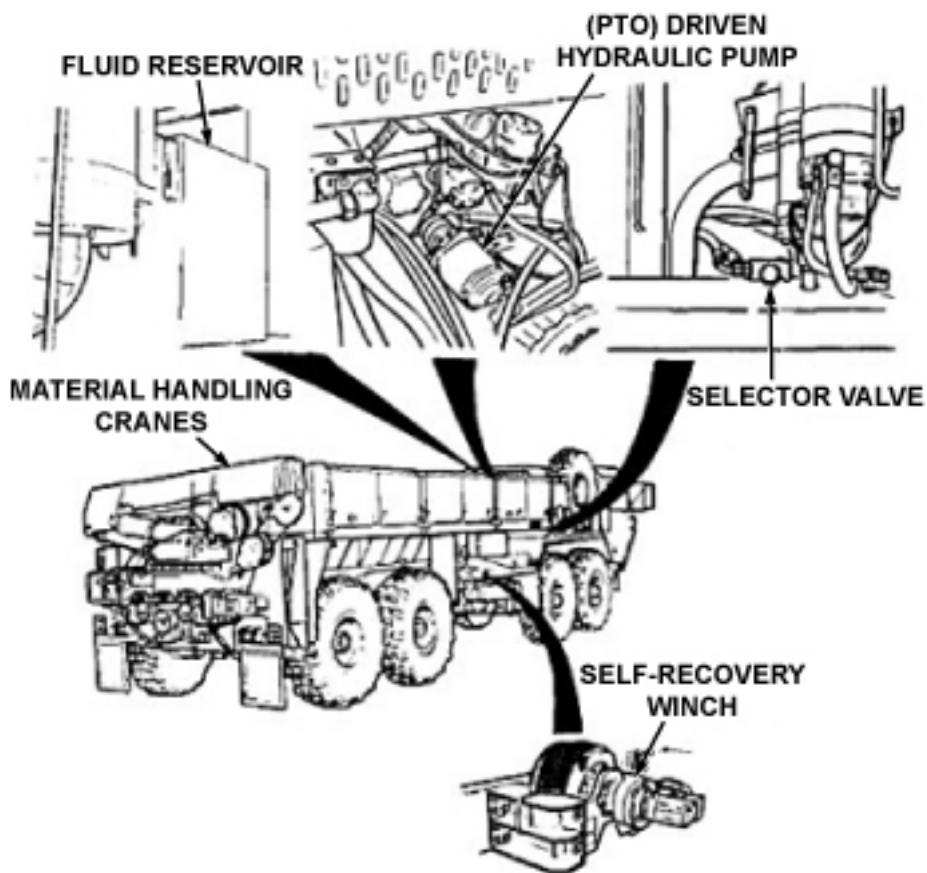

Figure 2.

2. Attempt to tighten loose hose(s) and/or connection(s).

CONDITION/INDICATION

Are hydraulic hoses and connections free from leaks and/or damage?

DECISION

Hydraulic hose or connection damaged. - Notify Supervisor. Test 3 - Do all hydraulic systems operate properly? Notify Supervisor.

Hydraulic hoses and connections OK. - Notify Supervisor.

TEST 3 - Do all hydraulic systems operate properly?

1. Start engine. (WP 0044)
2. Operate hydraulic systems to check for proper operation.

CONDITION/INDICATION

Do all hydraulic systems operate properly?

DECISION

No - Notify Supervisor.

Yes - Problem corrected.

END OF WORK PACKAGE

**OPERATOR MAINTENANCE
BOOM OPERATION ABNORMAL WHEN TELESCOPING IN OR OUT**

INITIAL SETUP:**Equipment Condition**

Vehicle setup for crane operations.
(WP 0042)

**TROUBLESHOOTING PROCEDURE
BOOM OPERATION ABNORMAL WHEN TELESCOPING IN OR OUT**

TEST 1 - Is HIGH IDLE ON/OFF switch set to ON position?**NOTE**

Common problems that crane operators may see are:

1. Slow or abnormal operation.
2. Crane will not pick up load.

Common causes of problems are:

1. Cold hydraulic oil (slow operation).
2. Low engine speed (slow or abnormal operation).
3. Operating two craning functions at the same time (slow operation).
4. Load too heavy (will not pick up load).
5. Air in cylinder or hoist motor (abnormal operation).

Report all problems to field level maintenance.

1. Ensure HIGH IDLE ON/OFF switch is set to ON position. If switch found in OFF position, turn switch to ON. (WP 0042)

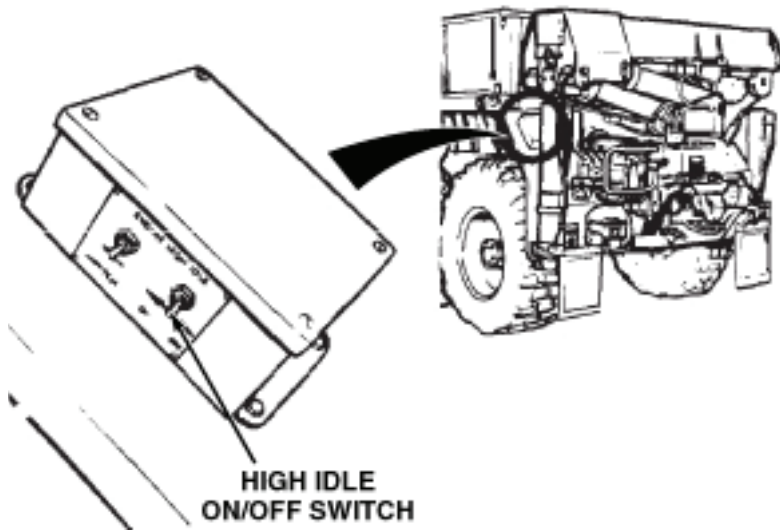

Figure 1.

CONDITION/INDICATION

Is HIGH IDLE ON/OFF switch set to ON position?

DECISION

No - Test 5 - Does boom operate normally when telescoping in or out?

Yes - Test 2 - Are boom sections properly lubricated?

TEST 2 - Are boom sections properly lubricated?

1. Inspect boom sections for proper lubrication.

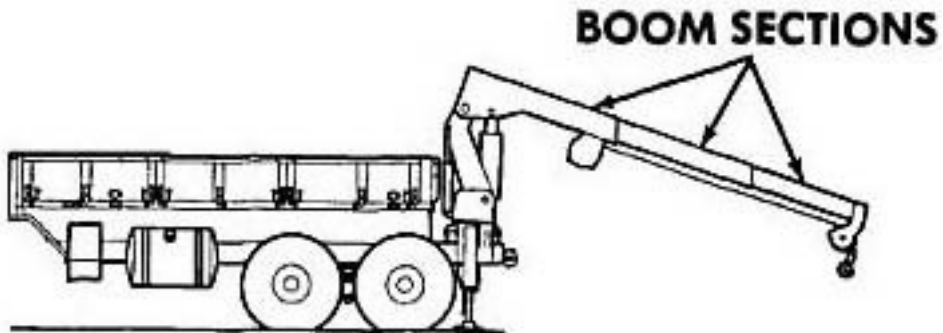

Figure 2.

CONDITION/INDICATION

Are boom sections properly lubricated?

DECISION

No - Lubricate boom sections. (WP 0149)

Yes - Test 3 - Are cylinders free from trapped air after telescoping boom in and out several times?

TEST 3 - Are cylinders free from trapped air after telescoping boom in and out several times?

1. Lower boom below horizontal position. (WP 0042)



Figure 3.

2. Fully TELESCOPE boom IN and OUT several times to remove air from cylinders. (WP 0042)

CONDITION/INDICATION

Are cylinders free from trapped air after telescoping boom in and out several times?

DECISION

No - Test 4 - Is boom operation normal after allowing boom to sit overnight?

Yes - Problem corrected.

TEST 4 - Is boom operation normal after allowing boom to sit overnight?

1. Swing boom to rear of vehicle. Fully telescope boom out. (WP 0042)
2. Lower boom as far as possible. (WP 0042)



Figure 4.

3. Shut down operation, (WP 0042) and allow boom to remain in lowered position overnight.
4. When starting operations, telescope boom in (WP 0042)(not out). Telescoping boom out could force air back into cylinders.
5. Telescope boom out and in. (WP 0042)

CONDITION/INDICATION

Is boom operation normal after allowing boom to sit overnight?

DECISION

No - Notify supervisor.

Yes - Problem corrected.

TEST 5 - Does boom operate normally when telescoping in or out?

1. Verify proper operation of boom telescoping. (WP 0042)



Figure 5.

CONDITION/INDICATION

Does boom operate normally when telescoping in or out?

DECISION

No - Notify supervisor.

Yes - Problem corrected.

END OF WORK PACKAGE

OPERATOR MAINTENANCE BOOM RAISES OR LOWERS SLOWLY

INITIAL SETUP:

Equipment Condition

Vehicle setup for crane operations.
(WP 0042)

TROUBLESHOOTING PROCEDURE BOOM RAISES OR LOWERS SLOWLY

TEST 1 - Does boom raise or lower normally after running engine for 20 minutes with PTO engaged?

NOTE

Common problems that crane operators may see are:

1. Slow or abnormal operation.
2. Crane will not pick up load.

Common causes of problems are:

1. Cold hydraulic fluid (slow operation).
2. Low engine speed (slow or abnormal operation).
3. Operating two craning functions at the same time (slow operation).
4. Load too heavy (will not pick up load).
5. Air in cylinder or hoist motor (abnormal operation).

Report all problems to field level maintenance.

If outside temperature is 0°F (-17°C), hydraulic fluid may not flow easily.

1. Start engine. (WP 0044)
2. Set PTO ENGAGE switch to ON. (WP 0042)

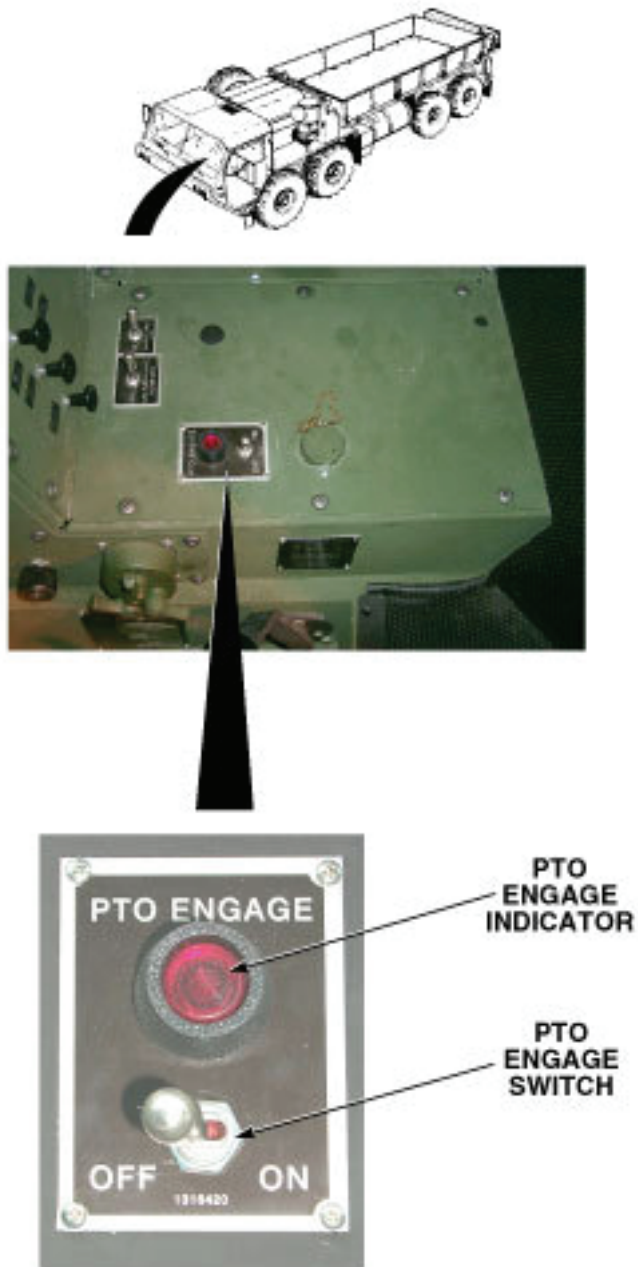

Figure 1.

3. Operate engine (WP 0044) for 20 minutes with PTO enabled to bring hydraulic fluid up to operating temperature.
4. Attempt to raise or lower boom. (WP 0042)

CONDITION/INDICATION

Does boom raise or lower normally after running engine for 20 minutes with PTO engaged?

DECISION

No - Test 2 - Does boom raise or lower normally after cycling mast?

Yes - Problem corrected.

TEST 2 - Does boom raise or lower normally after cycling mast?

1. Lower crane to stowed position. (WP 0042)
2. Operate MAST control DOWN. (WP 0042) Hold MAST control DOWN for approximately 30 seconds, then return control to NEUTRAL position. Repeat procedure several times until hydraulic fluid is warmed.

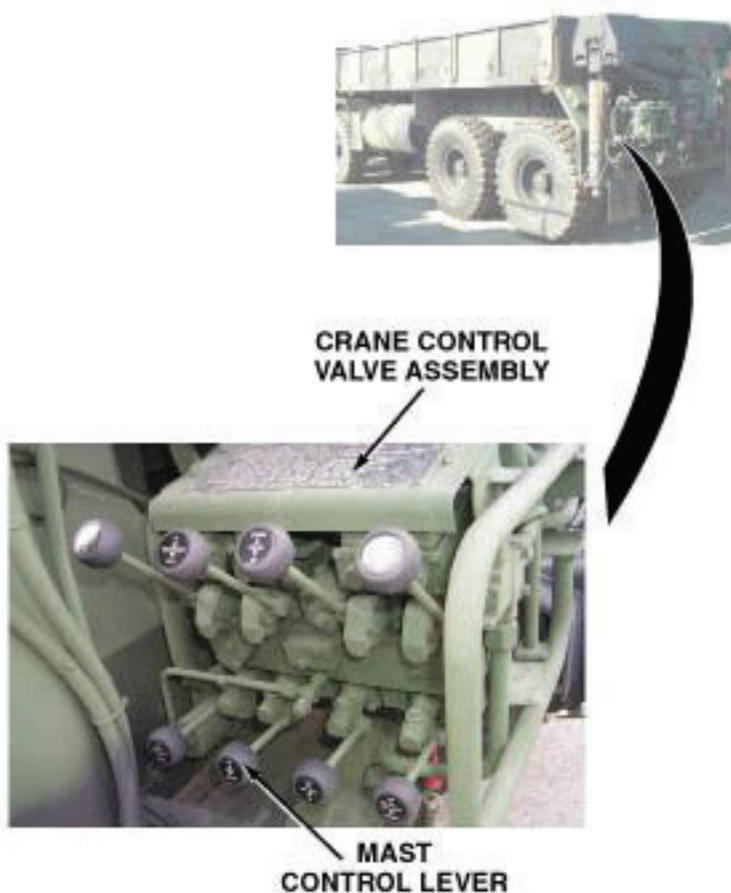

Figure 2.

3. Raise crane to operating position. (WP 0042)
4. Raise and lower boom. (WP 0042)

CONDITION/INDICATION

Does boom raise or lower normally after cycling mast?

DECISION

No - Notify Supervisor.
Yes - Problem corrected.

END OF WORK PACKAGE

OPERATOR MAINTENANCE BOOM WILL NOT RAISE OR LOWER

INITIAL SETUP:

Equipment Condition

Vehicle setup for crane operations.
(WP 0042)

TROUBLESHOOTING PROCEDURE BOOM WILL NOT RAISE OR LOWER

TEST 1 - Does boom operate after checking for overloading?

NOTE

Common problems that crane operators may see are:

1. Slow or abnormal operation.
2. Crane will not pick up load.

Common causes of problems are:

1. Cold hydraulic fluid (slow operation).
2. Low engine speed (slow or abnormal operation).
3. Operating two craning functions at the same time (slow operation).
4. Load too heavy (crane will not pick up load).
5. Air in cylinder or hoist motor (abnormal operation).

Report all problems to field level maintenance.

1. Check that load is not over load limit. If load is found to be over limit, reduce weight to below load limit.

RANGE DIAGRAM M977
ALL DIMENSIONS ARE IN FEET UNLESS OTHERWISE SPECIFIED

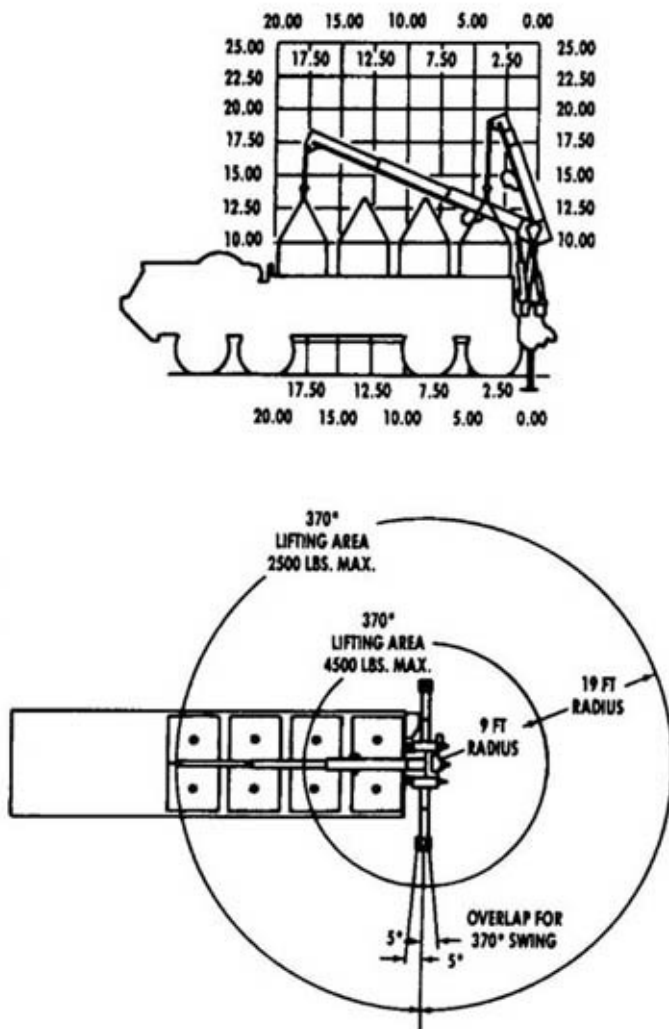

Figure 1.

2. Raise and lower boom. (WP 0042)

CONDITION/INDICATION

Does boom operate after checking for overloading?

DECISION

- No - Notify supervisor.
- Yes - Problem corrected.

END OF WORK PACKAGE

**OPERATOR MAINTENANCE
BOOM WILL NOT TELESCOPE IN OR OUT**

INITIAL SETUP:

Equipment Condition

Vehicle setup for crane operations.
(WP 0042)

**TROUBLESHOOTING PROCEDURE
BOOM WILL NOT TELESCOPE IN OR OUT**

TEST 1 - Does boom telescope in or out after checking for overloaded condition?

NOTE

Common problems that crane operators may see are:

1. Slow or abnormal operation.
2. Crane will not pick up load.

Common causes of problems are:

1. Cold hydraulic fluid (slow operation).
2. Low engine speed (slow or abnormal operation).
3. Operating two craning functions at the same time (slow operation).
4. Load too heavy (crane will not pick up load).
5. Air in cylinder or hoist motor (abnormal operation).

Report all problems to field level maintenance.

1. Check that load is not over load limit. If load is found to be over limit, reduce weight to below load limit.

RANGE DIAGRAM M977
ALL DIMENSIONS ARE IN FEET UNLESS OTHERWISE SPECIFIED

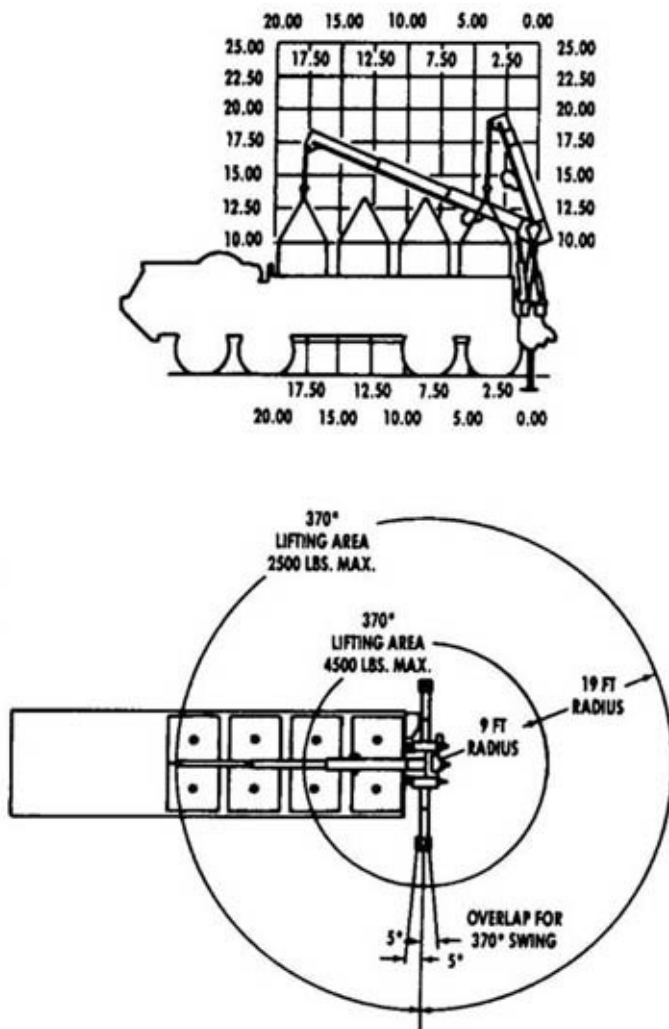

Figure 1.

2. Operate crane by telescoping boom IN and OUT. (WP 0042)

CONDITION/INDICATION

Does boom telescope in or out after checking for overloaded condition?

DECISION

- No - Notify supervisor.
- Yes - Problem corrected.

END OF WORK PACKAGE

OPERATOR MAINTENANCE CRANE CONTROLS STICKING IN ENGAGED POSITION

INITIAL SETUP:

Equipment Condition

Vehicle setup for crane operations.
(WP 0042)

TROUBLESHOOTING PROCEDURE CRANE CONTROLS STICKING IN ENGAGED POSITION

TEST 1 - Is hydraulic fluid at normal operating temperature?

WARNING



Reservoir may be very hot. Use care when placing hand near reservoir. Reservoir can become hot enough to cause serious burns. Be careful not to touch the reservoir with bare hands or allow body to contact reservoir. Use gloves and insulated pads as necessary. Failure to comply may result in injury or death to personnel.

NOTE

Common problems that crane operator may see are:

1. Slow or abnormal operation.
2. Crane will not pick up load.

Common causes of problems are:

1. Cold hydraulic fluid (slow operation).
2. Low engine speed (slow or abnormal operation).
3. Operating two craning functions at the same time (slow operation).
4. Load too heavy (crane will not pick up load).
5. Air in cylinder or hoist motor (abnormal operation).

Report all problems to field level maintenance.

NOTE

If outside temperature is 0°F (-17°C) or lower, hydraulic fluid may not flow easily.

1. Check hydraulic fluid temperature at reservoir.



HYDRAULIC
RESERVOIR

Figure 1.

CONDITION/INDICATION

Is hydraulic fluid at normal operating temperature?

DECISION

Hydraulic fluid is below normal operating temperature. - Test 2 - Does hydraulic fluid reach normal operating temperature after running engine for 20 minutes with PTO engaged? Test 4 - Is hydraulic fluid overheated?

Hydraulic fluid is at normal operating temperature. - Test 5 - Do crane controls operate normally after hydraulic fluid is at normal operating temperature?

TEST 2 - Does hydraulic fluid reach normal operating temperature after running engine for 20 minutes with PTO engaged?

WARNING

Reservoir may be very hot. Use care when placing hand near reservoir. Reservoir can become hot enough to cause serious burns. Be careful not to touch the reservoir with bare hands or allow body to contact reservoir.

Use gloves and insulated pads as necessary. Failure to comply may result in injury or death to personnel.

1. Set PTO ENGAGE switch to ON. (WP 0042)

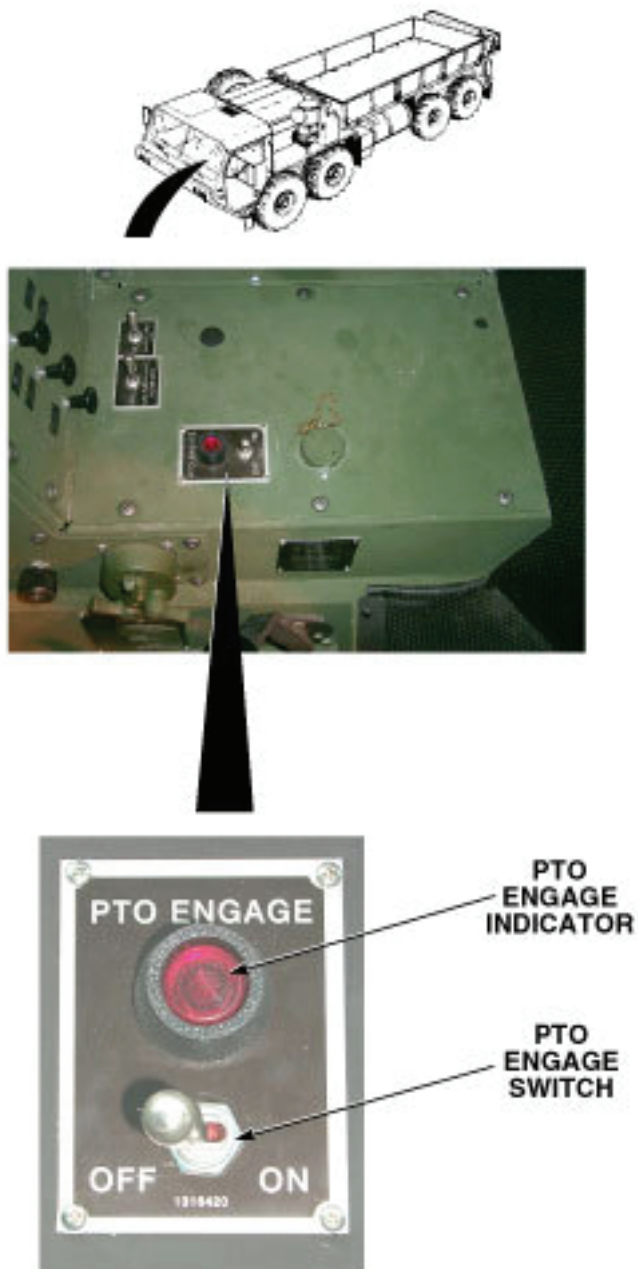

Figure 2.

2. Operate engine (WP 0044) for 20 minutes with PTO enabled to bring hydraulic fluid up to operating temperature.
3. Check hydraulic fluid temperature at reservoir. Reservoir should be warm.

CONDITION/INDICATION

Does hydraulic fluid reach normal operating temperature after running engine for 20 minutes with PTO engaged?

DECISION

Hydraulic fluid is below normal operating temperature. - Test 3 - Does hydraulic fluid reach normal operating temperature after cycling mast control down? Test 4 - Is hydraulic fluid overheated?

Hydraulic fluid is at normal operating temperature. - Test 5 - Do crane controls operate normally after hydraulic fluid is at normal operating temperature?

TEST 3 - Does hydraulic fluid reach normal operating temperature after cycling mast control down?**WARNING**

Reservoir may be very hot. Use care when placing hand near reservoir. Reservoir can become hot enough to cause serious burns. Be careful not to touch the reservoir with bare hands or allow body to contact reservoir. Use gloves and insulated pads as necessary. Failure to comply may result in injury or death to personnel.

1. Lower crane to stowed position. (WP 0042)
2. Operate MAST control DOWN. (WP 0042) Hold MAST control DOWN for approximately 30 seconds, then return control to NEUTRAL position. Repeat procedure several times until hydraulic fluid is warmed.

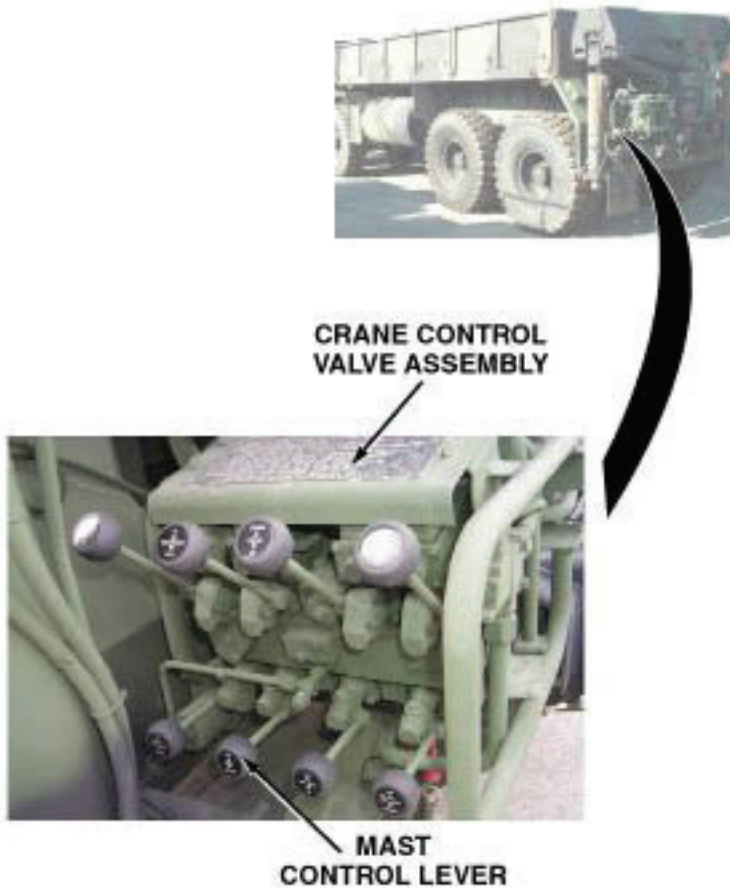

Figure 3.

3. Check hydraulic fluid temperature at reservoir. Reservoir should be warm.

CONDITION/INDICATION

Does hydraulic fluid reach normal operating temperature after cycling mast control down?

DECISION

Hydraulic fluid is below normal operating temperature. - Notify Supervisor. Test 4 - Is hydraulic fluid overheated?

Hydraulic fluid is at normal operating temperature. - Test 5 - Do crane controls operate normally after hydraulic fluid is at normal operating temperature?

TEST 4 - Is hydraulic fluid overheated?**WARNING**

Reservoir may be very hot. Use care when placing hand near reservoir. Reservoir can become hot enough to cause serious burns. Be careful not to touch the reservoir with bare hands or allow body to contact reservoir. Use gloves and insulated pads as necessary. Failure to comply may result in injury or death to personnel.

1. Set PTO ENGAGE switch to OFF.
2. Shut off engine. (WP 0057)
3. Allow hydraulic oil to cool. (WP 0057)



**HYDRAULIC
RESERVOIR**

Figure 4.

CONDITION/INDICATION

Is hydraulic fluid overheated?

DECISION

-

Continue - Test 5 - Do crane controls operate normally after hydraulic fluid is at normal operating temperature?

TEST 5 - Do crane controls operate normally after hydraulic fluid is at normal operating temperature?

1. If off, start engine. (WP 0044)

2. Prepare vehicle for crane operation. (WP 0042)

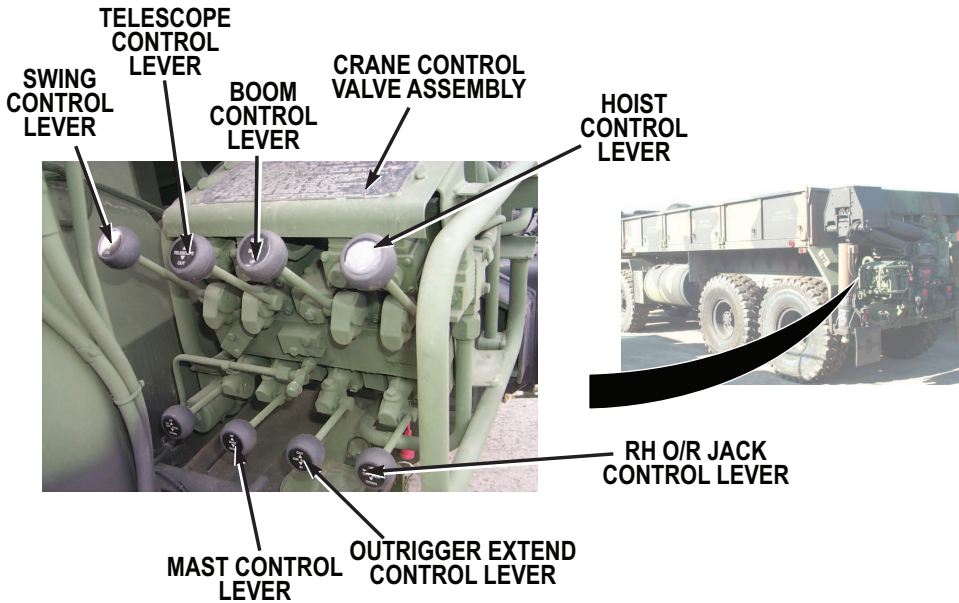

Figure 5.

3. Operate crane controls. (WP 0042)

CONDITION/INDICATION

Do crane controls operate normally after hydraulic fluid is at normal operating temperature?

DECISION

No - Notify supervisor.
 Yes - Problem corrected.

END OF WORK PACKAGE

**OPERATOR MAINTENANCE
CRANE WILL NOT OPERATE, OR OPERATES ABNORMALLY**

INITIAL SETUP:**Equipment Condition**

Engine OFF. (WP 0057)

Equipment Condition - Continued

Parking brakes applied. (WP 0056)

Wheels chocked. (WP 0077)

TROUBLESHOOTING PROCEDURE**CRANE WILL NOT OPERATE, OR OPERATES ABNORMALLY****TEST 1 - Is electrical connector on solenoid tight?****NOTE**

Common problems that crane operators may see are:

1. Slow or abnormal operation.
2. Crane will not pick up load.

Common causes of problems are:

1. Cold hydraulic fluid (slow operation).
2. Low engine speed (slow or abnormal operation).
3. Operating two craning functions at the same time (slow operation).
4. Load too heavy (crane will not pick up load).
5. Air in cylinder or hoist motor (abnormal operation).

Report all problems to field level maintenance.

1. Check that electrical connector on solenoid valve is tight. If connector is loose, tighten.

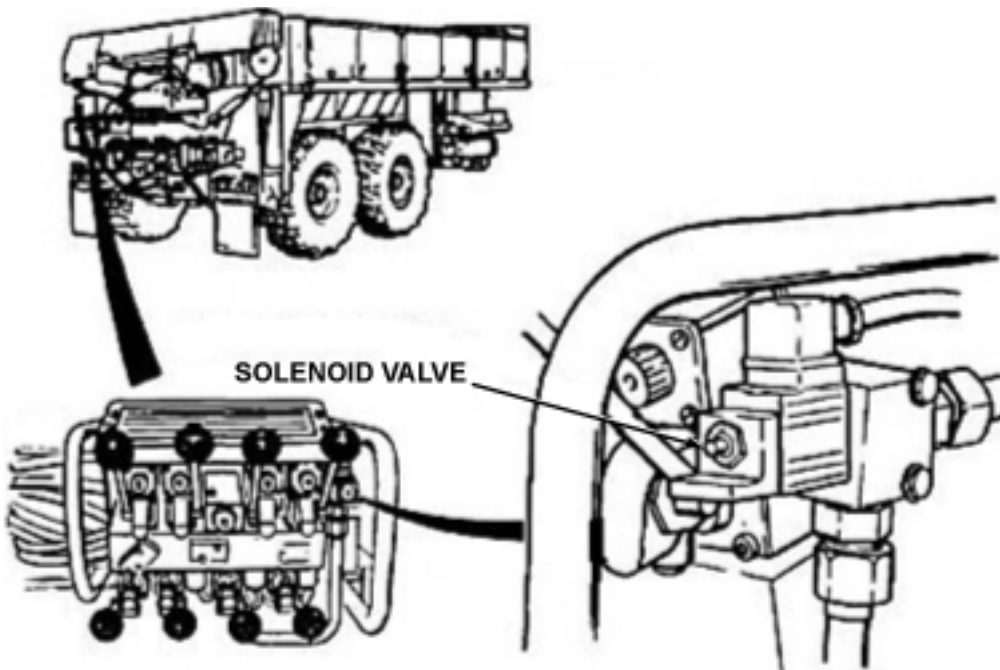

Figure 1.

CONDITION/INDICATION

Is electrical connector on solenoid tight?

DECISION

No - Test 3 - Does crane operate normally?

Yes - Test 2 - Does solenoid valve operate when power switch is set to ON?

TEST 2 - Does solenoid valve operate when power switch is set to ON?

1. Check solenoid for proper operation when power is turned to ON position. (WP 0042) If solenoid is faulty, place a screwdriver in slot on front of solenoid to hold solenoid closed (WP 0104) until mission can be completed.

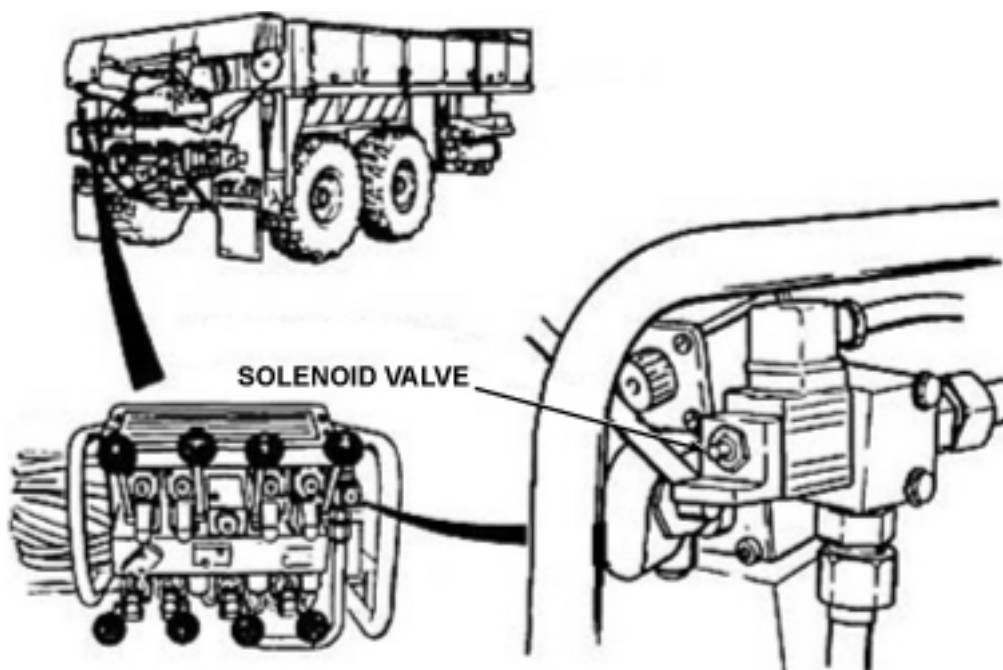

Figure 2.

CONDITION/INDICATION

Does solenoid valve operate when power switch is set to ON?

DECISION

No - Perform crane emergency hydraulic procedure. (WP 0104)

Yes - Notify Supervisor.

TEST 3 - Does crane operate normally?

1. Prepare vehicle for crane operation. (WP 0042)

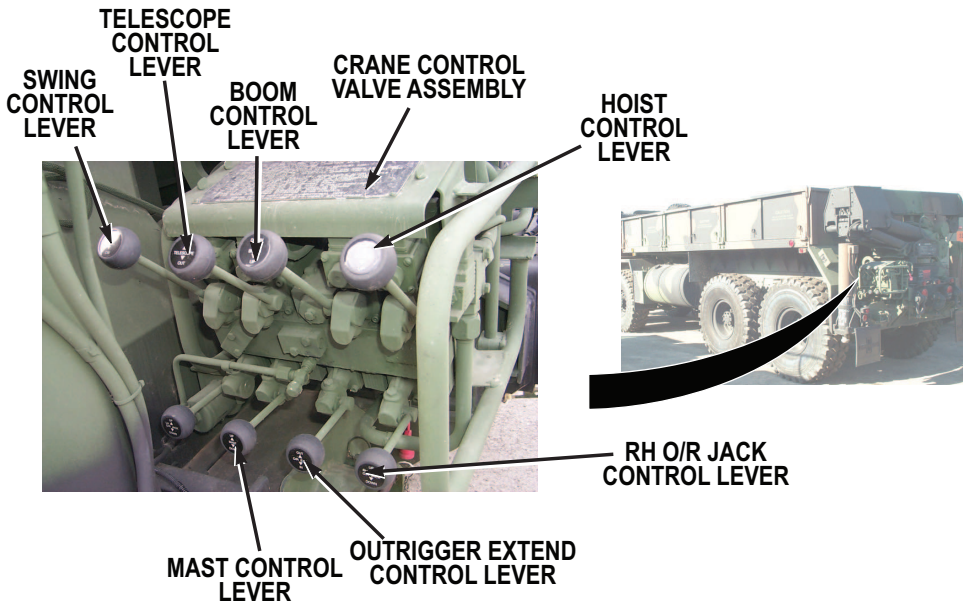

Figure 3.

2. Operate crane. (WP 0042)

CONDITION/INDICATION

Does crane operate normally?

DECISION

No - Notify supervisor.
 Yes - Problem corrected.

END OF WORK PACKAGE

OPERATOR MAINTENANCE
HOIST OPERATION SLOW OR ABNORMAL WHEN LIFTING OR LOWERING LOAD

INITIAL SETUP:**Equipment Condition**

Vehicle setup for crane operations.
(WP 0042)

TROUBLESHOOTING PROCEDURE
HOIST OPERATION SLOW OR ABNORMAL WHEN LIFTING OR LOWERING LOAD

TEST 1 - Does hoist operate normally after removing air from motor?**CAUTION**

Be sure to keep tension on cable. If tension is not maintained, cable may get tangled on drum.

NOTE

Common problems that crane operators may see are:

1. Slow or abnormal operation.
2. Crane will not pick up load.

Common causes of problems are:

1. Cold hydraulic fluid (slow operation).
2. Low engine speed (slow or abnormal operation).
3. Operating two craning functions at the same time (slow operation).
4. Load too heavy (crane will not pick up load).
5. Air in cylinder or hoist motor (abnormal operation).

Report all problems to field level maintenance.

1. Set load down (WP 0042) and disconnect load hook.
2. Reel cable in and out several times to remove air from hoist motor.

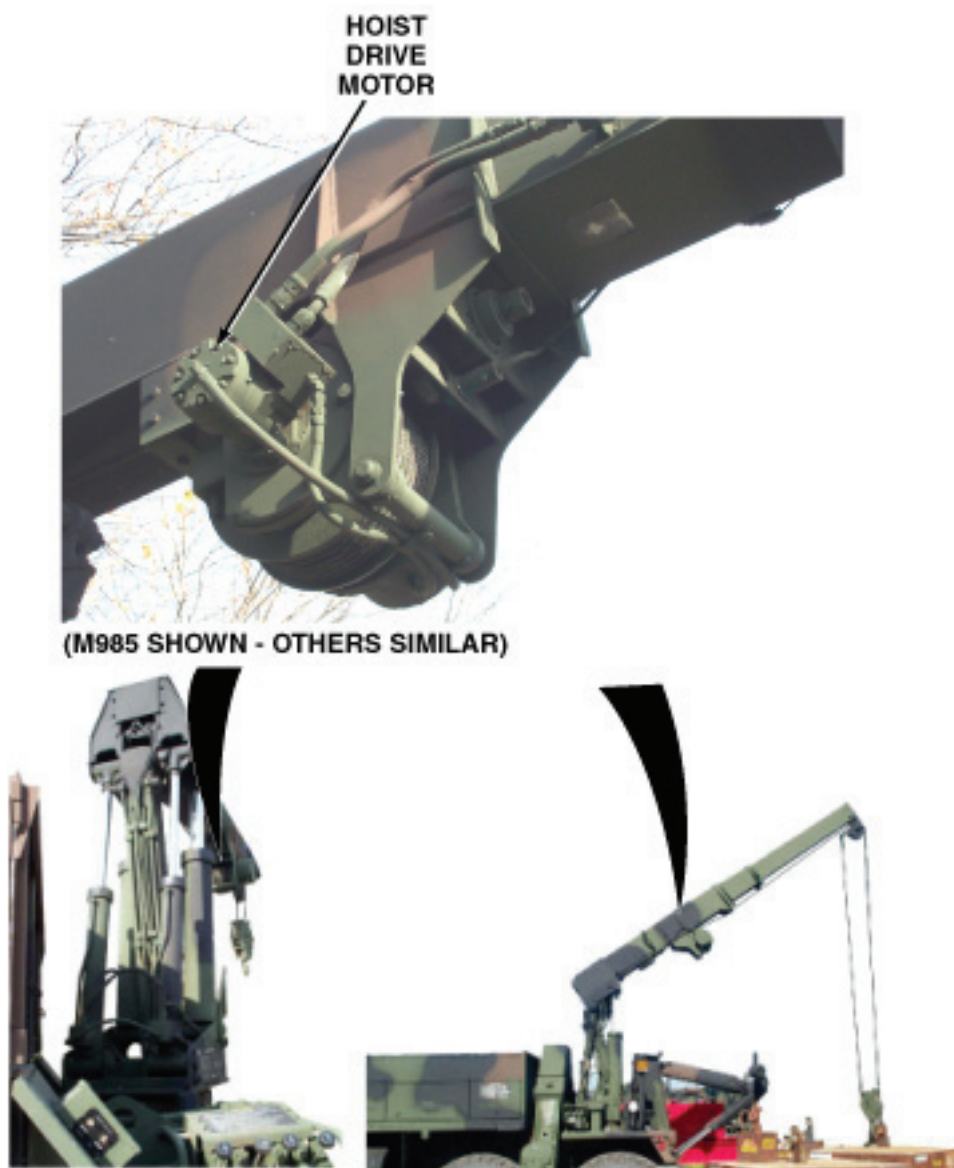

Figure 1.

CONDITION/INDICATION

Does hoist operate normally after removing air from motor?

DECISION

- No - Test 2 - Is hydraulic fluid at normal operating temperature?
- Yes - Test 5 - Does hoist operate normally?

TEST 2 - Is hydraulic fluid at normal operating temperature?**WARNING**

Reservoir may be very hot. Use care when placing hand near reservoir. Reservoir can become hot enough to cause serious burns. Be careful not to touch the reservoir with bare hands or allow body to contact reservoir. Use gloves and insulated pads as necessary. Failure to comply may result in injury or death to personnel.

NOTE

If outside temperature is 0°F (-17°C) or lower, hydraulic fluid may not flow easily.

1. Check hydraulic fluid temperature at reservoir.



**HYDRAULIC
RESERVOIR**

Figure 2.

CONDITION/INDICATION

- Is hydraulic fluid at normal operating temperature?

DECISION

No - Test 3 - Is hydraulic fluid at normal operating temperature after running engine for 20 minutes with PTO engaged?

Yes - Test 5 - Does hoist operate normally?

TEST 3 - Is hydraulic fluid at normal operating temperature after running engine for 20 minutes with PTO engaged?**WARNING**

Reservoir may be very hot. Use care when placing hand near reservoir. Reservoir can become hot enough to cause serious burns. Be careful not to touch the reservoir with bare hands or allow body to contact reservoir. Use gloves and insulated pads as necessary. Failure to comply may result in injury or death to personnel.

1. Lower crane to stowed position. (WP 0042)
2. Operate engine (WP 0044) for 20 minutes with PTO engaged to bring hydraulic fluid up to operating temperature.
3. Check hydraulic fluid temperature at reservoir. Reservoir should be warm.



**HYDRAULIC
RESERVOIR**

Figure 3.

CONDITION/INDICATION

Is hydraulic fluid at normal operating temperature after running engine for 20 minutes with PTO engaged?

DECISION

No - Test 4 - Is hydraulic fluid at normal operating temperature after cycling mast control down?

Yes - Test 5 - Does hoist operate normally?

TEST 4 - Is hydraulic fluid at normal operating temperature after cycling mast control down?

1. Ensure crane is lowered to stowed position. (WP 0042)
2. Operate MAST control DOWN. (WP 0042) Hold MAST control DOWN for approximately 30 seconds, then return control to NEUTRAL position. Repeat procedure several times until hydraulic fluid is warmed.

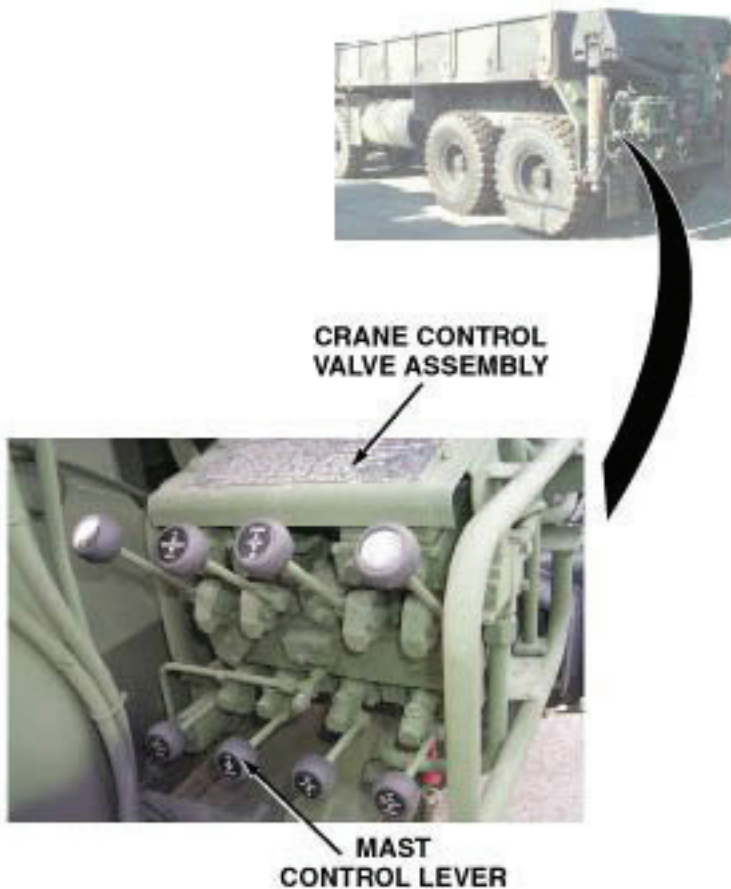

Figure 4.

3. Check hydraulic fluid temperature at reservoir. Reservoir should be warm.

CONDITION/INDICATION

Is hydraulic fluid at normal operating temperature after cycling mast control down?

DECISION

No - Notify Supervisor.

Yes - Test 5 - Does hoist operate normally?

TEST 5 - Does hoist operate normally?

1. If stowed, raise crane to operating position. (WP 0042)
2. Operate hoist. (WP 0042)



Figure 5.

CONDITION/INDICATION

Does hoist operate normally?

DECISION

No - Notify supervisor.

Yes - Problem corrected.

END OF WORK PACKAGE

**OPERATOR MAINTENANCE
HOIST WILL NOT LIFT LOAD**

INITIAL SETUP:**Equipment Condition**

Vehicle setup for crane operations.
(WP 0042)

**TROUBLESHOOTING PROCEDURE
HOIST WILL NOT LIFT LOAD****TEST 1 - Is load within allowable limits?****NOTE**

Common problems that crane operators may see are:

1. Slow or abnormal operation.
2. Crane will not pick up load.

Common causes of problems are:

1. Cold hydraulic fluid (slow operation).
2. Low engine speed (slow or abnormal operation).
3. Operating two craning functions at the same time (slow operation).
4. Load too heavy (crane will not pick up load).
5. Air in cylinder or hoist motor (abnormal operation).

Report all problems to field level maintenance.

1. Check that load is not over load limit. If load is found to be over-limit, reduce weight to below load limit.

RANGE DIAGRAM M977
ALL DIMENSIONS ARE IN FEET UNLESS OTHERWISE SPECIFIED

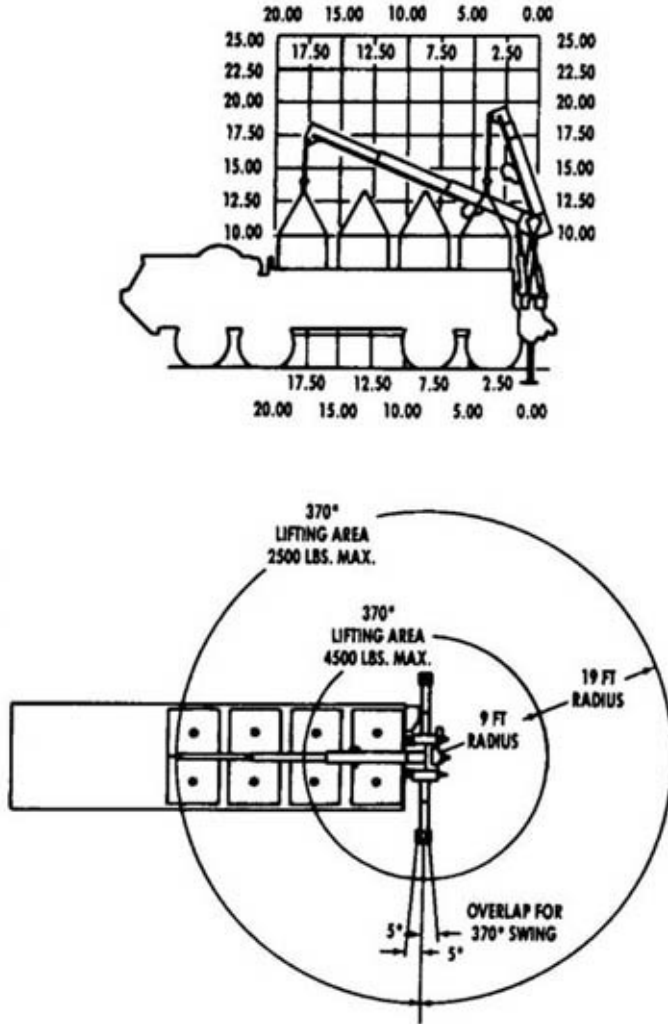

Figure 1.

CONDITION/INDICATION

Is load within allowable limits?

DECISION

No - Test 2 - Does hoist lift load?

Yes - Notify Supervisor.

TEST 2 - Does hoist lift load?

1. Operate hoist up and down. (WP 0042)

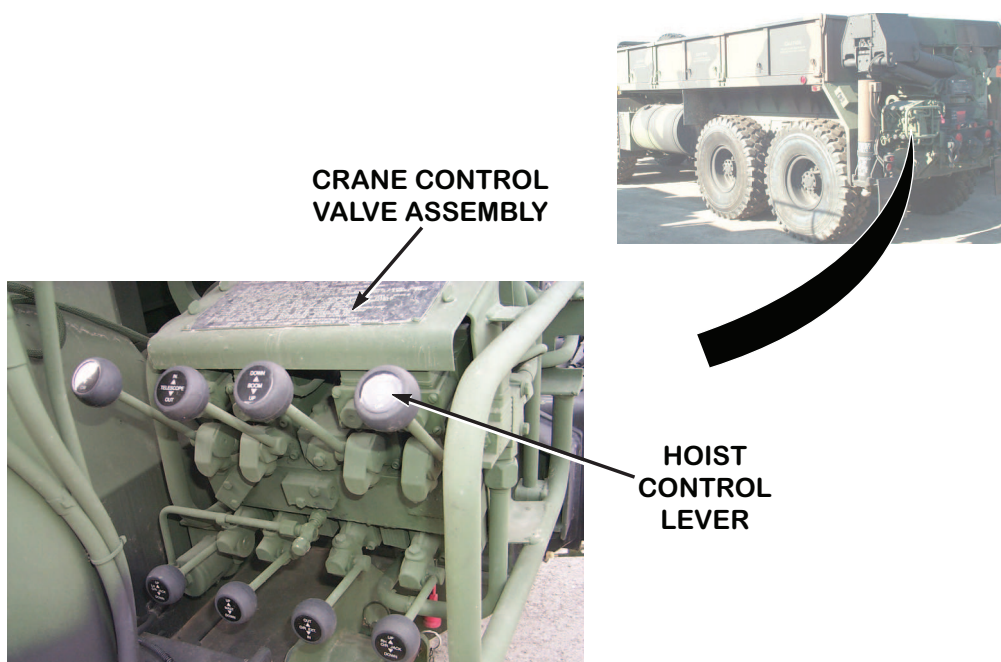

Figure 2.

CONDITION/INDICATION

Does hoist lift load?

DECISION

No - Notify supervisor.
Yes - Problem corrected.

END OF WORK PACKAGE

**OPERATOR MAINTENANCE
MAST RAISES OR LOWERS ABNORMALLY**

INITIAL SETUP:

Equipment Condition

Vehicle setup for crane operations.
(WP 0042)

**TROUBLESHOOTING PROCEDURE
MAST RAISES OR LOWERS ABNORMALLY**

TEST 1 - Does mast raise and lower normally after cycling mast up and down to remove trapped air?

NOTE

Common problems that crane operators may see are:

1. Slow or abnormal operation.
2. Crane will not pick up load.

Common causes of problems are:

1. Cold hydraulic fluid (slow operation).
2. Low engine speed (slow or abnormal operation).
3. Operating two craning functions at the same time (slow operation).
4. Load too heavy (crane will not pick up load).
5. Air in cylinder or hoist motor (abnormal operation).

Report all problems to field level maintenance.

1. Fully raise and lower mast (WP 0042) several times to remove air from cylinders.

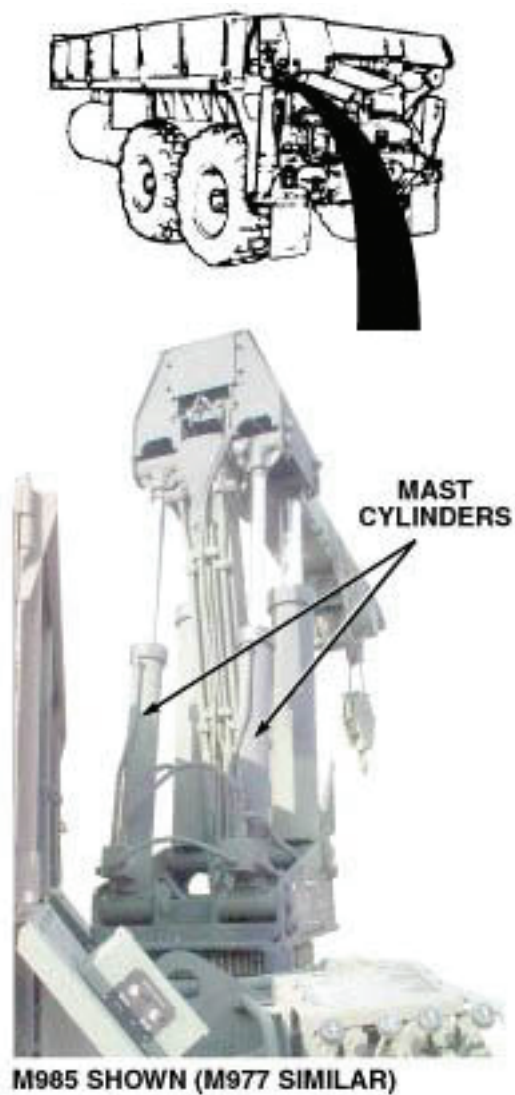

Figure 1.

CONDITION/INDICATION

Does mast raise and lower normally after cycling mast up and down to remove trapped air?

DECISION

- Notify supervisor. Test 2 - Does mast operate normally after leaving mast in fully raised position overnight?

Yes - Problem corrected.

- Notify supervisor. Test 2 - Does mast operate normally after leaving mast in fully raised position overnight?

No - Problem corrected.

TEST 2 - Does mast operate normally after leaving mast in fully raised position overnight?

1. Raise boom to vertical position. (WP 0042)

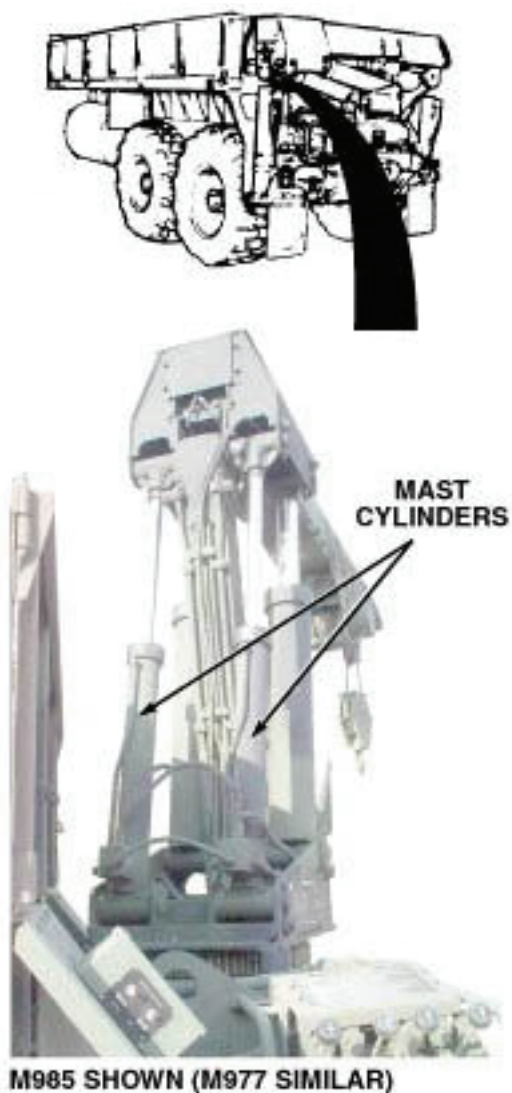

Figure 2.

2. Fully raise mast. (WP 0042)
3. Shut down operation (WP 0042) and leave mast in raised position overnight.
4. Start engine. (WP 0044)
5. Prepare vehicle for crane operations. (WP 0042)

NOTE

When starting operations, operate mast control down (not up) first. Operating controls UP could force air back into cylinders.

6. Lower and raise mast. (WP 0042)

CONDITION/INDICATION

Does mast operate normally after leaving mast in fully raised position overnight?

DECISION

No - Notify supervisor.

Yes - Problem corrected.

END OF WORK PACKAGE

OPERATOR MAINTENANCE MAST RAISES OR LOWERS SLOWLY

INITIAL SETUP:

Equipment Condition

Vehicle setup for crane operations.
(WP 0042)

TROUBLESHOOTING PROCEDURE MAST RAISES OR LOWERS SLOWLY

TEST 1 - Does mast raise and lower normally after running engine for 20 minutes with PTO engaged?

NOTE

Common problems that crane operators may see are:

1. Slow or abnormal operation.
2. Crane will not pick up load.

Common causes of problems are:

1. Cold hydraulic fluid (slow operation).
2. Low engine speed (slow or abnormal operation).
3. Operating two craning functions at the same time (slow operation).
4. Load too heavy (crane will not pick up load).
5. Air in cylinder or hoist motor (abnormal operation).

Report all problems to field level maintenance.

If outside temperature is 0°F (-17°C), hydraulic fluid may not flow easily.

1. If loaded, set load down (WP 0042) and disconnect load hook.
2. Operate engine (WP 0044) for 20 minutes with PTO ENGAGE switch set to ON to bring hydraulic fluid up to operating temperature.

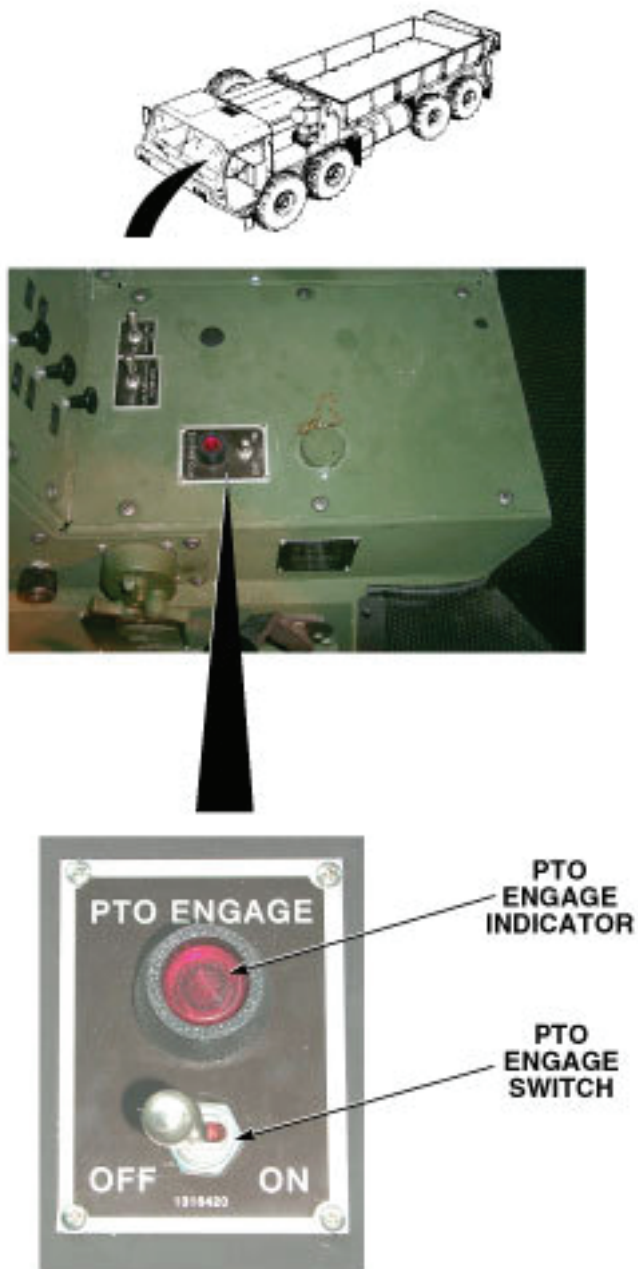

Figure 1.

3. Raise and lower mast. (WP 0042)

CONDITION/INDICATION

Does mast raise and lower normally after running engine for 20 minutes with PTO engaged?

DECISION

No - Test 2 - Does mast raise and lower normally after cycling mast?
Yes - Problem corrected.

TEST 2 - Does mast raise and lower normally after cycling mast?

1. Lower crane to stowed position. (WP 0042)
2. Operate MAST control DOWN. (WP 0042) Hold MAST control DOWN for approximately 30 seconds, then return control to NEUTRAL position. Repeat procedure several times until hydraulic fluid is warmed.

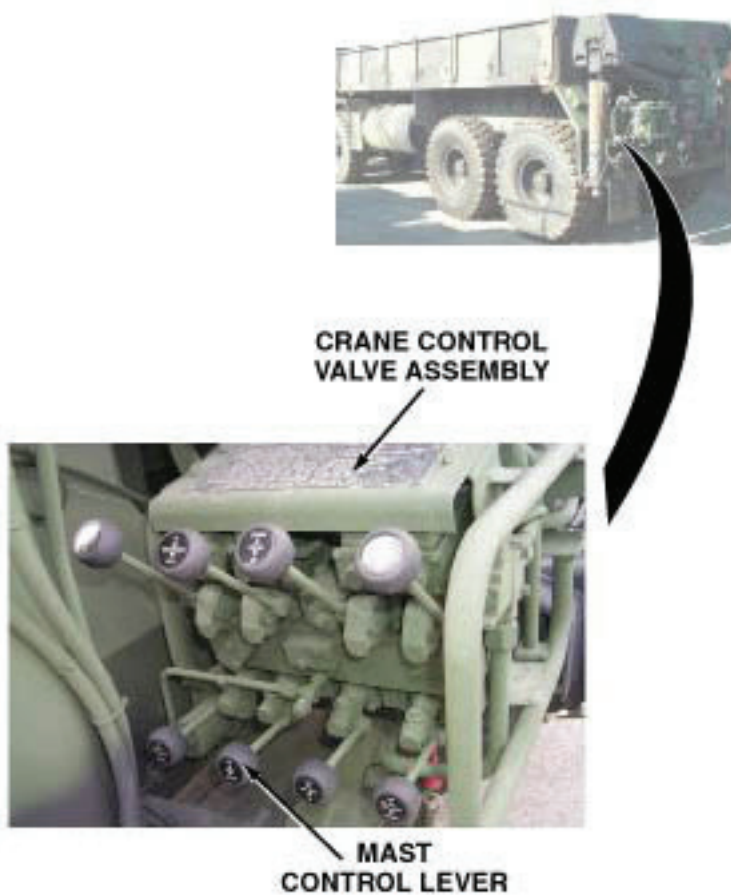

Figure 2.

3. Raise and lower mast. (WP 0042)

CONDITION/INDICATION

Does mast raise and lower normally after cycling mast?

DECISION

No - Notify supervisor.

Yes - Problem corrected.

END OF WORK PACKAGE

OPERATOR MAINTENANCE OUTRIGGER OPERATION SLOW OR ABNORMAL

INITIAL SETUP:

Equipment Condition

Vehicle setup for crane operations.
(WP 0042)

TROUBLESHOOTING PROCEDURE OUTRIGGER OPERATION SLOW OR ABNORMAL

TEST 1 - Is hydraulic fluid at normal operating temperature?

WARNING



Reservoir may be very hot. Use care when placing hand near reservoir. Reservoir can become hot enough to cause serious burns. Be careful not to touch the reservoir with bare hands or allow body to contact reservoir. Use gloves and insulated pads as necessary. Failure to comply may result in injury or death to personnel.

NOTE

Common problems that crane operators may see are:

1. Slow or abnormal operation.
2. Crane will not pick up load.

Common causes of problems are:

1. Cold hydraulic fluid (slow operation).
2. Low engine speed (slow or abnormal operation).
3. Operating two craning functions at the same time (slow operation).
4. Load too heavy (crane will not pick up load).
5. Air in cylinder or hoist motor (abnormal operation).

Report all problems to field level maintenance.

If outside temperature is 0°F (-17°C) or lower, hydraulic fluid may not flow easily.

1. Check hydraulic fluid temperature at reservoir.



HYDRAULIC
RESERVOIR

Figure 1.

CONDITION/INDICATION

Is hydraulic fluid at normal operating temperature?

DECISION

No - Test 2 - Is hydraulic fluid at normal operating temperature after running engine for 20 minutes with PTO engaged?

Yes - Test 4 - Do outriggers operate normally?

TEST 2 - Is hydraulic fluid at normal operating temperature after running engine for 20 minutes with PTO engaged?

WARNING



Reservoir may be very hot. Use care when placing hand near reservoir. Reservoir can become hot enough to cause serious burns. Be careful not to touch the reservoir with bare hands or allow body to contact reservoir. Use gloves and insulated pads as necessary. Failure to comply may result in injury or death to personnel.

1. Start engine. (WP 0044)
2. Set PTO ENGAGE switch to ON. (WP 0042)

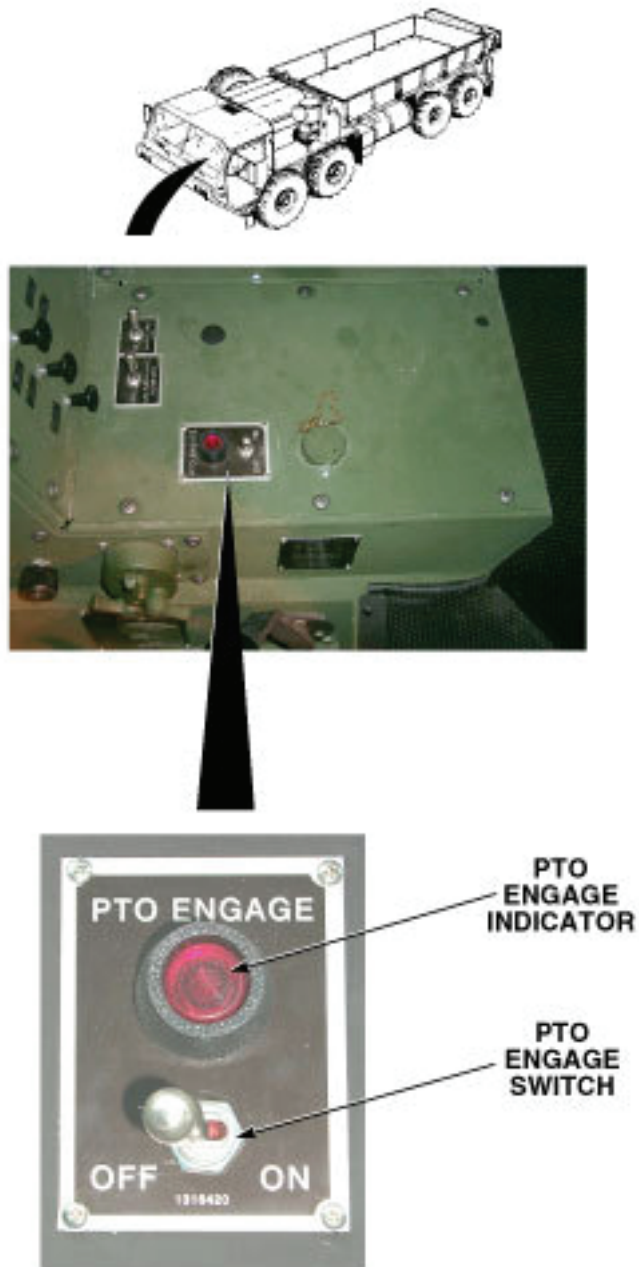

Figure 2.

3. Operate engine (WP 0044) for 20 minutes with PTO enabled to bring hydraulic fluid up to operating temperature.
4. Check hydraulic fluid temperature at reservoir. Reservoir should be warm.

CONDITION/INDICATION

Is hydraulic fluid at normal operating temperature after running engine for 20 minutes with PTO engaged?

DECISION

No - Test 3 - Is hydraulic fluid at normal operating temperature normal operating temperature after cycling mast control down?

Yes - Test 4 - Do outriggers operate normally?

TEST 3 - Is hydraulic fluid at normal operating temperature normal operating temperature after cycling mast control down?

1. Ensure crane is lowered to stowed position. (WP 0042)
2. Operate MAST control DOWN. (WP 0042) Hold MAST control DOWN for approximately 30 seconds, then return control to NEUTRAL position. Repeat procedure several times until hydraulic fluid is warmed.



Figure 3.

3. Check hydraulic fluid temperature at reservoir. Reservoir should be warm.

CONDITION/INDICATION

Is hydraulic fluid at normal operating temperature normal operating temperature after cycling mast control down?

DECISION

No - Notify Supervisor.

Yes - Test 4 - Do outriggers operate normally?

TEST 4 - Do outriggers operate normally?

1. Ensure crane is lowered to stowed position. (WP 0042)
2. Operate outrigger. (WP 0042)

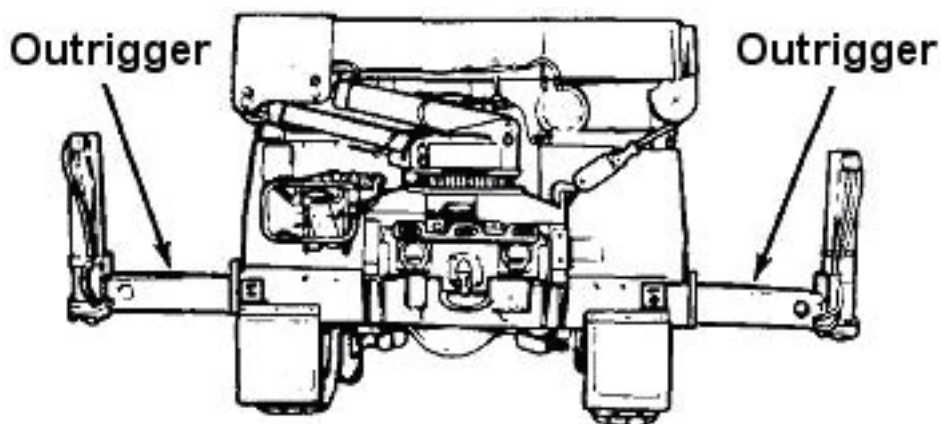

Figure 4.

CONDITION/INDICATION

Do outriggers operate normally?

DECISION

No - Test 5 - Do outriggers operate normally after purging cylinders of air?

Yes - Problem corrected.

TEST 5 - Do outriggers operate normally after purging cylinders of air?

1. Fully let out and draw back outriggers (WP 0042) several times to remove air from cylinders.

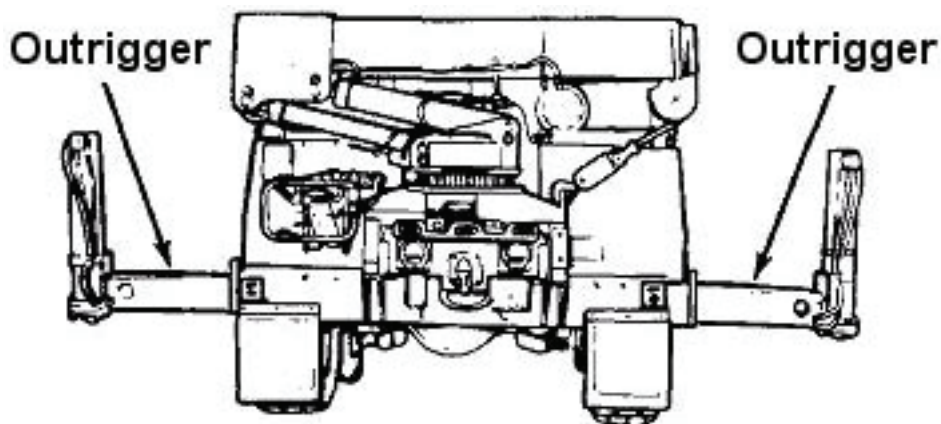

Figure 5.

2. Operate outriggers (WP 0042)

CONDITION/INDICATION

Do outriggers operate normally after purging cylinders of air?

DECISION

No - Notify Supervisor.

Yes - Problem corrected.

END OF WORK PACKAGE

**OPERATOR MAINTENANCE
SWING OPERATION ABNORMAL IN BOTH DIRECTIONS**

INITIAL SETUP:**Equipment Condition**

Vehicle setup for crane operations.
(WP 0042)

**TROUBLESHOOTING PROCEDURE
SWING OPERATION ABNORMAL IN BOTH DIRECTIONS**

TEST 1 - Are control levers returned to neutral properly?**NOTE**

Common problems that crane operators may see are:

1. Slow or abnormal operation.
2. Crane will not pick up load.

Common causes of problems are:

1. Cold hydraulic fluid (slow operation).
2. Low engine speed (slow or abnormal operation).
3. Operating two craning functions at the same time (slow operation).
4. Load too heavy (crane will not pick up load).
5. Air in cylinder or hoist motor (abnormal operation).

Report all problems to field level maintenance.

1. Verify that abnormal operation is not due to sharp movement of controls to NEUTRAL position.



Figure 1.

2. Feather control lever to NEUTRAL (WP 0042) to maintain smooth stopping action.

CONDITION/INDICATION

Are control levers returned to neutral properly?

DECISION

No - Test 2 - Is vehicle level?
 Yes - Problem corrected.

TEST 2 - Is vehicle level?

1. Check if vehicle is level.



Figure 2.

CONDITION/INDICATION

Is vehicle level?

DECISION

- Level vehicle. Level vehicle. (WP 0042)

Yes - Test 3 - Is turntable bearing properly lubricated?

- Level vehicle. Level vehicle. (WP 0042)

No - Test 3 - Is turntable bearing properly lubricated?

TEST 3 - Is turntable bearing properly lubricated?

1. Check turntable bearing for proper lubrication.

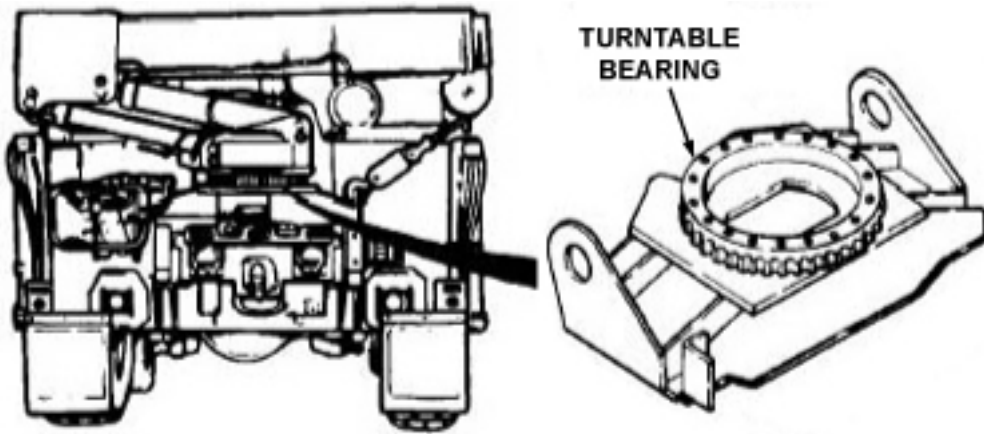

Figure 3.

2. If improperly lubricated, rotate turntable 360 degrees (WP 0042) in both directions several times, and lubricate turntable bearing. (WP 0149)

CONDITION/INDICATION

Is turntable bearing properly lubricated?

DECISION

- Test 5 - Does swing operate normally?
- Yes - Test 4 - Is load within allowable limit?
- Test 5 - Does swing operate normally?
- No - Test 4 - Is load within allowable limit?

TEST 4 - Is load within allowable limit?

1. Verify that load is below weight limit.

RANGE DIAGRAM M977
ALL DIMENSIONS ARE IN FEET UNLESS OTHERWISE SPECIFIED

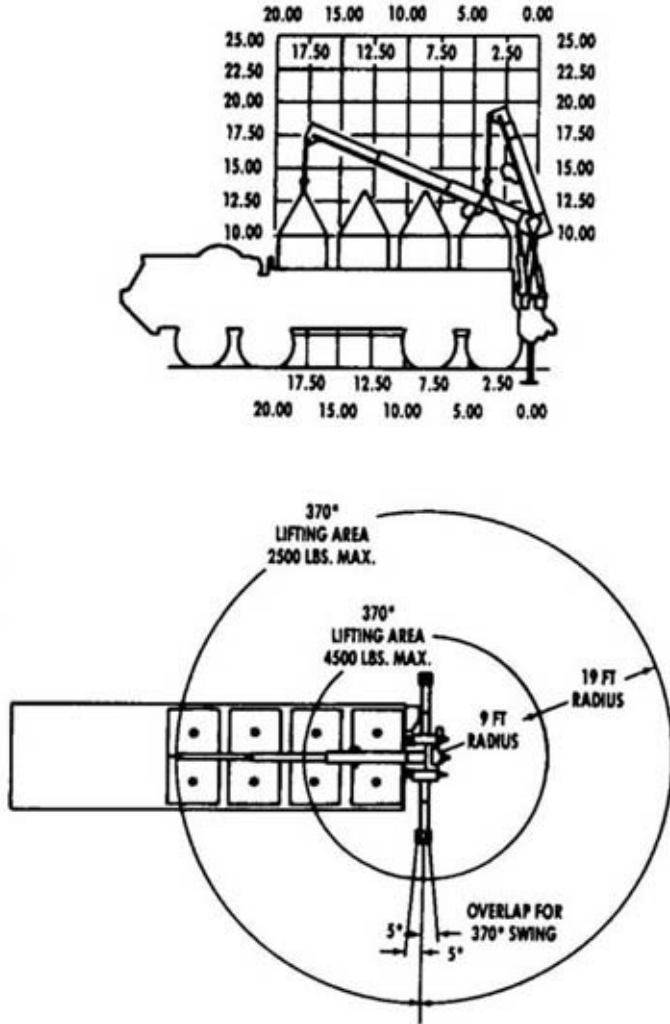

Figure 4.

2. If above weight limit, remove weight to decrease it to below the limit.

CONDITION/INDICATION

Is load within allowable limit?

DECISION

- No - Test 5 - Does swing operate normally?
- Yes - Notify Supervisor.

TEST 5 - Does swing operate normally?

1. Operate crane (WP 0042) to verify proper operation of swing.



Figure 5.

CONDITION/INDICATION

Does swing operate normally?

DECISION

- No - Notify Supervisor.
- Yes - Problem corrected.

END OF WORK PACKAGE

OPERATOR MAINTENANCE
SWING OPERATION ABNORMAL IN ONLY ONE DIRECTION

INITIAL SETUP:**Equipment Condition**

Vehicle setup for crane operations.
(WP 0042)

TROUBLESHOOTING PROCEDURE
SWING OPERATION ABNORMAL IN ONLY ONE DIRECTION

TEST 1 - Is vehicle level?**NOTE**

Common problems that crane operators may see are:

1. Slow or abnormal operation.
2. Crane will not pick up load.

Common causes of problems are:

1. Cold hydraulic fluid (slow operation).
2. Low engine speed (slow or abnormal operation).
3. Operating two craning functions at the same time (slow operation).
4. Load too heavy (crane will not pick up load).
5. Air in cylinder or hoist motor (abnormal operation).

Report all problems to field level maintenance.

1. Check if vehicle is level.



Figure 1.

CONDITION/INDICATION

Is vehicle level?

DECISION

Vehicle not level. - Level vehicle. (WP 0042)

Vehicle level. - Test 2 - Is turntable bearing properly lubricated?

TEST 2 - Is turntable bearing properly lubricated?

1. Check turntable bearing for proper lubrication.

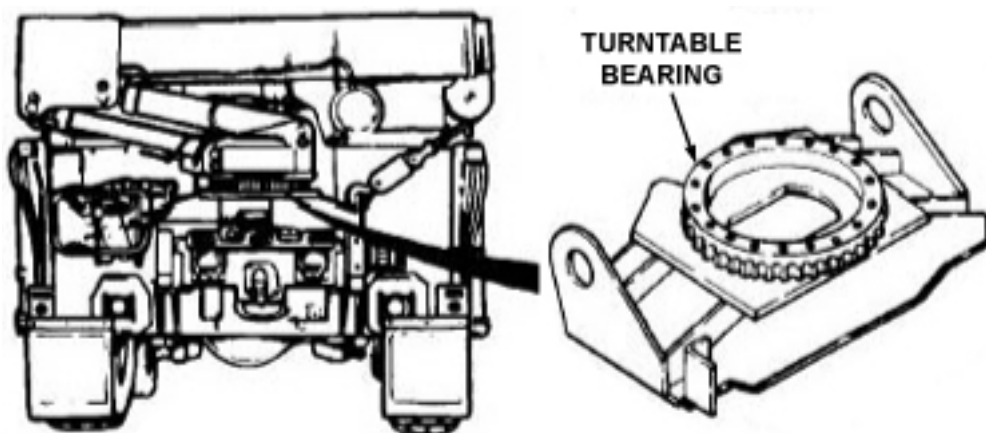

Figure 2.

2. If improperly lubricated, rotate turntable 360 degrees (WP 0042) in both directions several times, and lubricate turntable bearing. (WP 0149)

CONDITION/INDICATION

Is turntable bearing properly lubricated?

DECISION

- Test 3 - Does swing operate normally?
- Yes - Test 3 - Does swing operate normally?
- Test 3 - Does swing operate normally?
- No - Test 3 - Does swing operate normally?

TEST 3 - Does swing operate normally?

1. Operate crane (WP 0042) to verify proper operation of swing.



Figure 3.

CONDITION/INDICATION

Does swing operate normally?

DECISION

No - Notify supervisor.

Yes - Problem corrected.

END OF WORK PACKAGE

**OPERATOR MAINTENANCE
SELF-RECOVERY WINCH DOES NOT WORK**

INITIAL SETUP:

Equipment Condition

Engine OFF. (WP 0057)

Equipment Condition - Continued

Parking brakes applied. (WP 0056)

Wheels chocked. (WP 0077)

TROUBLESHOOTING PROCEDURE

SELF-RECOVERY WINCH DOES NOT WORK

TEST 1 - Is hydraulic fluid level within normal operating range?

1. Check hydraulic fluid level. If low, add hydraulic fluid. (WP 0147)

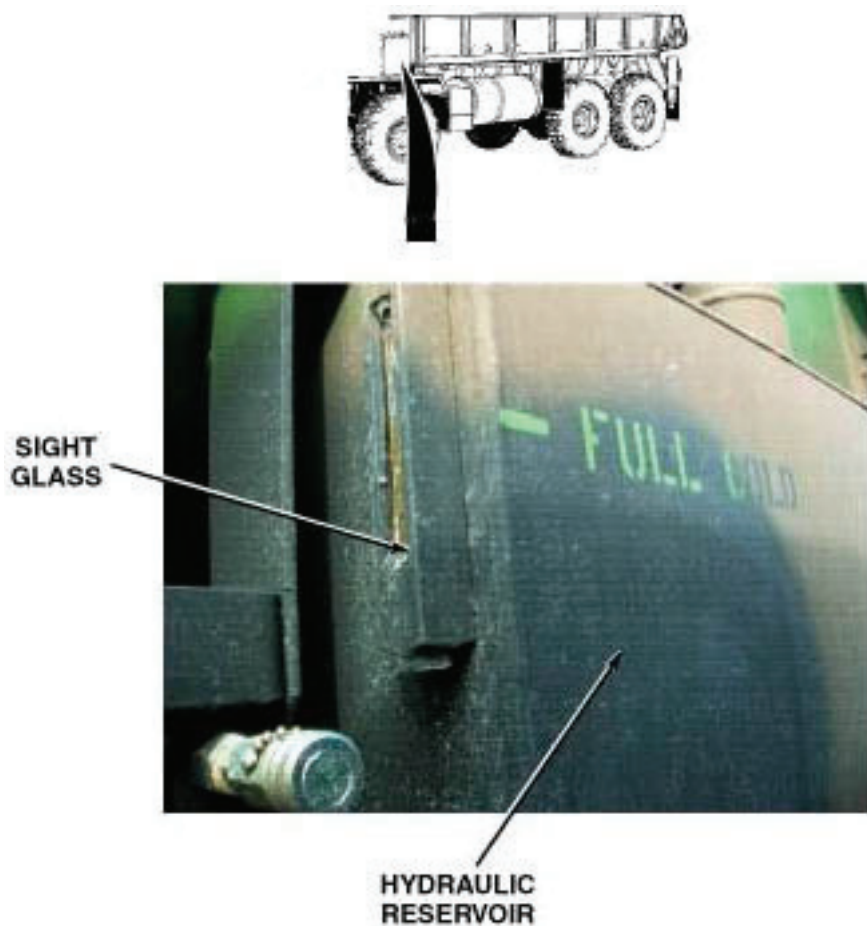

Figure 1.

CONDITION/INDICATION

Is hydraulic fluid level within normal operating range?

DECISION

No - Test 3 - Does self-recovery winch operate properly?

Yes - Test 2 - Is self-recovery winch shift linkage free from debris and damage?

TEST 2 - Is self-recovery winch shift linkage free from debris and damage?

1. Check self-recovery winch shift linkage for debris and damage. If debris found, clean shift linkage. (WP 0154)



Figure 2.

CONDITION/INDICATION

Is self-recovery winch shift linkage free from debris and damage?

DECISION

Linkage damaged. - Notify Supervisor. Test 3 - Does self-recovery winch operate properly? Notify Supervisor.

Linkage OK. - Notify Supervisor.

TEST 3 - Does self-recovery winch operate properly?

1. Start engine. (WP 0044)
2. Check operation of self-recovery winch. (WP 0087)

CONDITION/INDICATION

Does self-recovery winch operate properly?

DECISION

No - Notify supervisor.

Yes - Problem corrected.

END OF WORK PACKAGE

OPERATOR MAINTENANCE UNUSUALLY NOISY WHEN OPERATING

INITIAL SETUP:

Equipment Condition

Engine OFF. (WP 0057)

Equipment Condition - Continued

Parking brakes applied. (WP 0056)

Wheels chocked. (WP 0077)

TROUBLESHOOTING PROCEDURE UNUSUALLY NOISY WHEN OPERATING

TEST 1 - Is self-recovery winch cable free of twists, tangles, or binding?

1. Check if self-recovery winch cable is twisted, tangled, or causing drum to bind. If cable is tangled, pay out or take up cable as necessary to straighten.

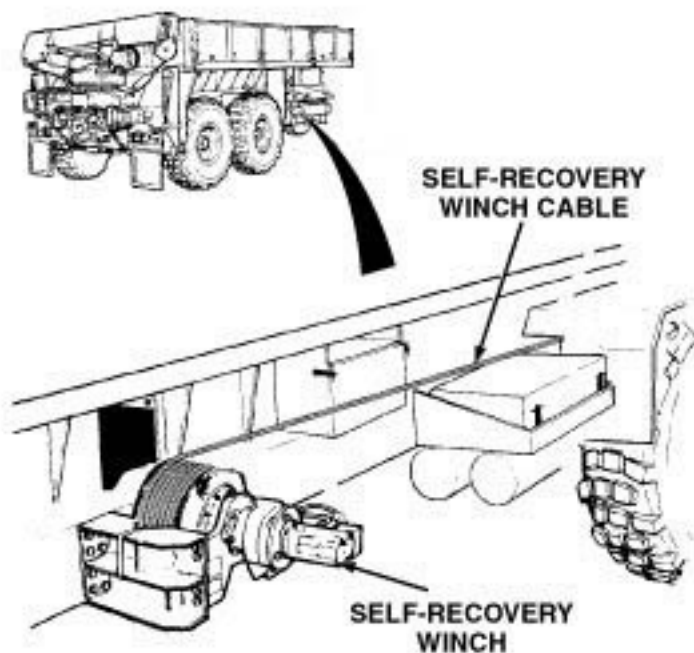

Figure 1.

CONDITION/INDICATION

Is self-recovery winch cable free of twists, tangles, or binding?

DECISION

No - Notify supervisor.

Yes - Test 2 - Is self-recovery winch free of unusual noise when operating?

TEST 2 - Is self-recovery winch free of unusual noise when operating?

1. Start engine. (WP 0044)



Figure 2.

2. Operate self-recovery winch, and listen for unusual noise. (WP 0087)

CONDITION/INDICATION

Is self-recovery winch free of unusual noise when operating?

DECISION

No - Notify supervisor.

Yes - Problem corrected.

END OF WORK PACKAGE

OPERATOR MAINTENANCE
VEHICLE IS HARD TO STEER, SHIMMIES, WANDERS, OR PULLS TO ONE SIDE

INITIAL SETUP:**Equipment Condition**

Engine OFF. (WP 0057)

Equipment Condition - Continued

Parking brakes applied. (WP 0056)

Wheels chocked. (WP 0077)

TROUBLESHOOTING PROCEDURE**VEHICLE IS HARD TO STEER, SHIMMIES, WANDERS, OR PULLS TO ONE SIDE****TEST 1 - Are tires inflated to proper pressure for road condition?****WARNING**

Tire air pressure must be checked properly. Failure to comply may result in injury or death to personnel.

NOTE

- Inflate tires only when they are cool. Inflate to proper pressure for road condition.
- Tire tread is non-directional. Vehicle operation is not affected by direction of traction bars.

1. Check tires for proper inflation. (WP 0145)

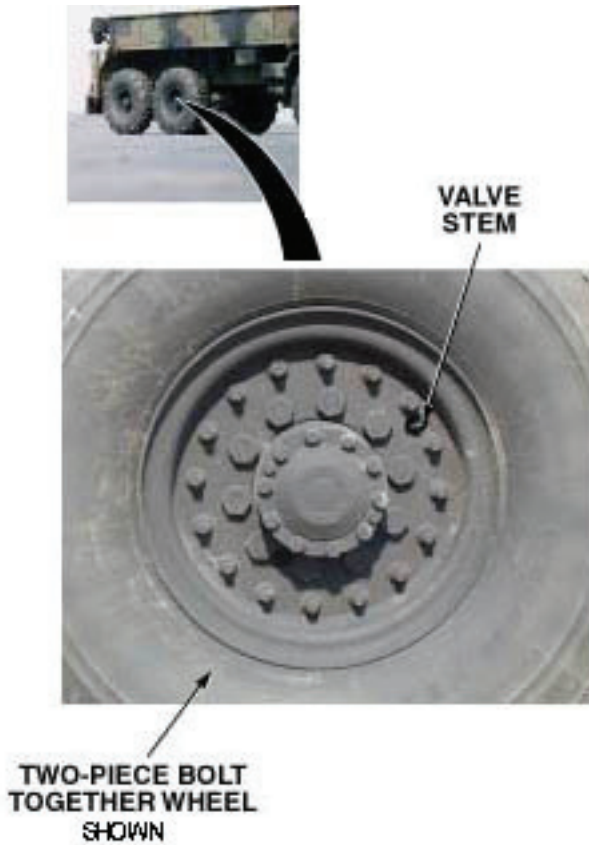

Figure 1.

2. If tires are improperly inflated, inflate or deflate tires to proper pressure.

CONDITION/INDICATION

Are tires inflated to proper pressure for road condition?

DECISION

Improperly inflated - Test 3 - Is vehicle hard to steer; or does it shimmy, wander, or pull to one side?

Inflation OK - Test 2 - Are wheels free of loose, missing, or broken lugnuts?

TEST 2 - Are wheels free of loose, missing, or broken lugnuts?

1. Check for loose, missing, or broken lugnuts.



Figure 2.

CONDITION/INDICATION

Are wheels free of loose, missing, or broken lugnuts?

DECISION

No - Tighten and/or replace loose, missing, or damaged lugnut(s). (WP 0155)

Yes - Notify Supervisor.

TEST 3 - Is vehicle hard to steer; or does it shimmy, wander, or pull to one side?

1. Start engine. (WP 0044)
2. Test drive vehicle.

CONDITION/INDICATION

Is vehicle hard to steer; or does it shimmy, wander, or pull to one side?

DECISION

No - Notify Supervisor.

Yes - Problem corrected.

END OF WORK PACKAGE

**OPERATOR MAINTENANCE
VEHICLE STEERING SLOW TO RESPOND OR INTERMITTENT**

INITIAL SETUP:**Equipment Condition**

Engine OFF. (WP 0057)

Equipment Condition - Continued

Parking brakes applied. (WP 0056)

Wheels chocked. (WP 0077)

TROUBLESHOOTING PROCEDURE**VEHICLE STEERING SLOW TO RESPOND OR INTERMITTENT****TEST 1 - Is hydraulic fluid low?**

1. Check for low hydraulic fluid. (WP 0147)
2. If fluid level is low, add hydraulic fluid. (WP 0147)

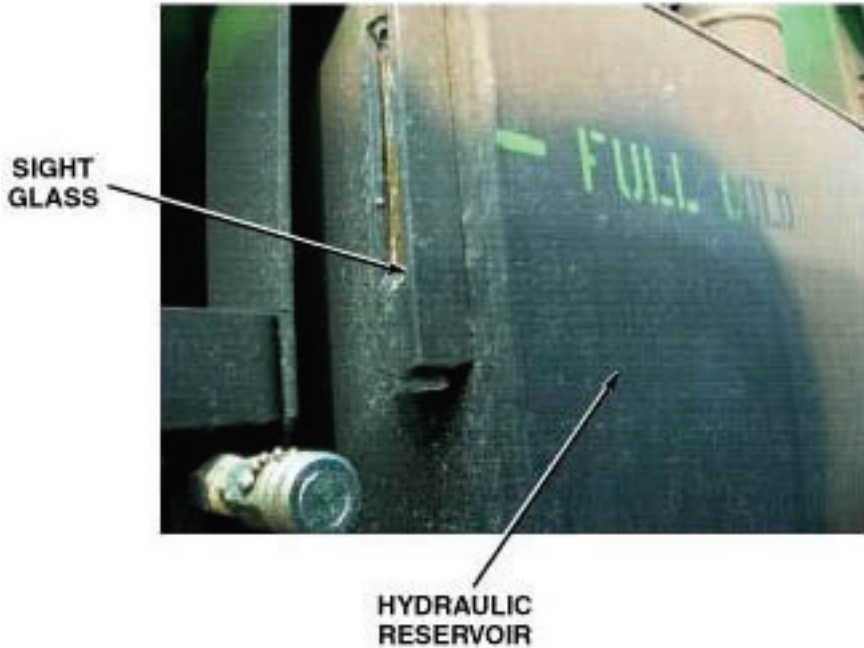

Figure 1.

CONDITION/INDICATION

Is hydraulic fluid low?

DECISION

Fluid level low - Test 3 - Is steering slow to respond or intermittent?

Fluid level OK - Test 2 - Are there any leaking or damaged hydraulic fittings or lines?

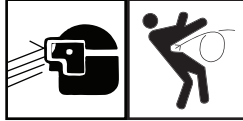
TEST 2 - Are there any leaking or damaged hydraulic fittings or lines?**WARNING**

Vehicles air system is pressurized, be sure to wear proper eye protection and keep face away from drain valves while draining air reservoirs. Open air drain valves slowly to prevent sudden blast of air. Failure to comply may result in injury to personnel.

1. Check for leaking or damaged hydraulic lines and/or fittings.

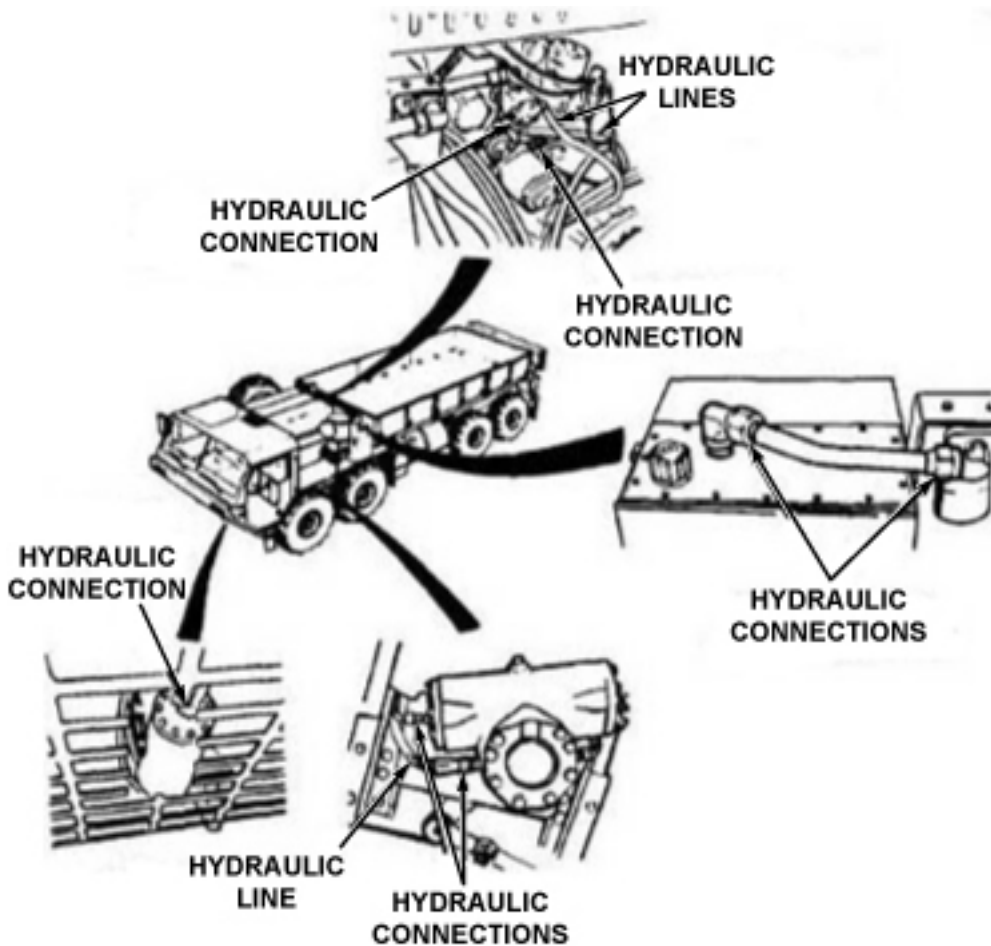

Figure 2.

2. If loose hydraulic fluid fittings are found, tighten fittings.

CONDITION/INDICATION

Are there any leaking or damaged hydraulic fittings or lines?

DECISION

Hydraulic lines damaged or leaking. - Ensure fittings are tightened and notify supervisor of faulty hydraulic lines. Tighten loose fittings. (Test 3 - Is steering slow to respond or intermittent?) Notify Supervisor.

No leaks, damaged lines or loose fittings found. - Notify Supervisor.

TEST 3 - Is steering slow to respond or intermittent?

1. Start engine. (WP 0044)

2. Test drive vehicle.

CONDITION/INDICATION

Is steering slow to respond or intermittent?

DECISION

Steering faulty - Notify Supervisor.

Steering OK - Problem corrected.

END OF WORK PACKAGE

OPERATOR MAINTENANCE UNUSUALLY NOISY WHEN OPERATING

INITIAL SETUP:

Equipment Condition

Engine OFF. (WP 0057)

Equipment Condition - Continued

Parking brakes applied. (WP 0056)

Wheels chocked. (WP 0077)

TROUBLESHOOTING PROCEDURE UNUSUALLY NOISY WHEN OPERATING

TEST 1 - Is transmission/transfer case free from unusual noise while operating?

1. Start engine. (WP 0044)
2. Test drive vehicle.



Figure 1.

CONDITION/INDICATION

Is transmission/transfer case free from unusual noise while operating?

DECISION

No - Notify supervisor.

Yes - Problem corrected.

END OF WORK PACKAGE

OPERATOR MAINTENANCE SLOW OR DIFFICULT ENGAGEMENT

INITIAL SETUP:

Equipment Condition

Engine OFF. (WP 0057)

Equipment Condition - Continued

Parking brakes applied. (WP 0056)

Wheels chocked. (WP 0077)

TROUBLESHOOTING PROCEDURE SLOW OR DIFFICULT ENGAGEMENT

TEST 1 - Does transmission and/or transfer case engage normally?

1. Start engine. (WP 0044)
2. Test drive vehicle.



Figure 1.

CONDITION/INDICATION

Does transmission and/or transfer case engage normally?

DECISION

No - Notify Supervisor.

Yes - Problem corrected.

END OF WORK PACKAGE

**OPERATOR MAINTENANCE
TRANSFER CASE SHIFT LEVER WILL NOT SHIFT**

INITIAL SETUP:**Equipment Condition**

Engine OFF. (WP 0057)

Equipment Condition - Continued

Parking brakes applied. (WP 0056)

Wheels chocked. (WP 0077)

**TROUBLESHOOTING PROCEDURE
TRANSFER CASE SHIFT LEVER WILL NOT SHIFT**

TEST 1 - Does transfer case shift lever shift when transmission is shifted from Neutral (N) to Drive (D)?

1. Start engine (WP 0044)
2. Move transmission range selector from Neutral (N) to Drive (D). Apply throttle to roll vehicle slightly, and shift transmission from (D) to (N). As vehicle stops, shift TRANSFER CASE shift lever.

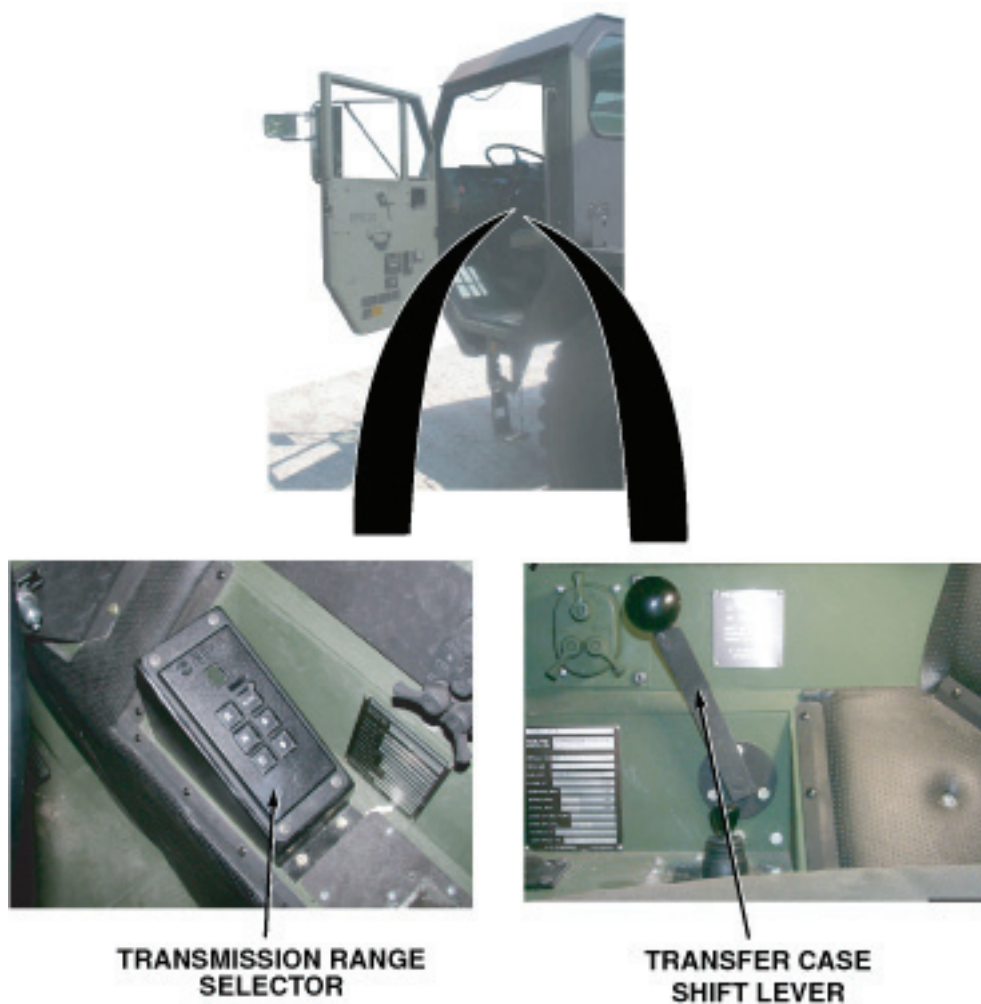

Figure 1.

CONDITION/INDICATION

Does transfer case shift lever shift when transmission is shifted from Neutral (N) to Drive (D)?

DECISION

No - Test 2 - Does transfer case shift lever shift when transmission is shifted from Neutral (N) to Reverse (R)?
Yes - Problem corrected.

TEST 2 - Does transfer case shift lever shift when transmission is shifted from Neutral (N) to Reverse (R)?

1. Move transmission range selector from Neutral (N) to Reverse (R). Apply throttle to roll vehicle slightly and shift transmission from R to N. As vehicle stops, shift TRANSFER CASE shift lever.

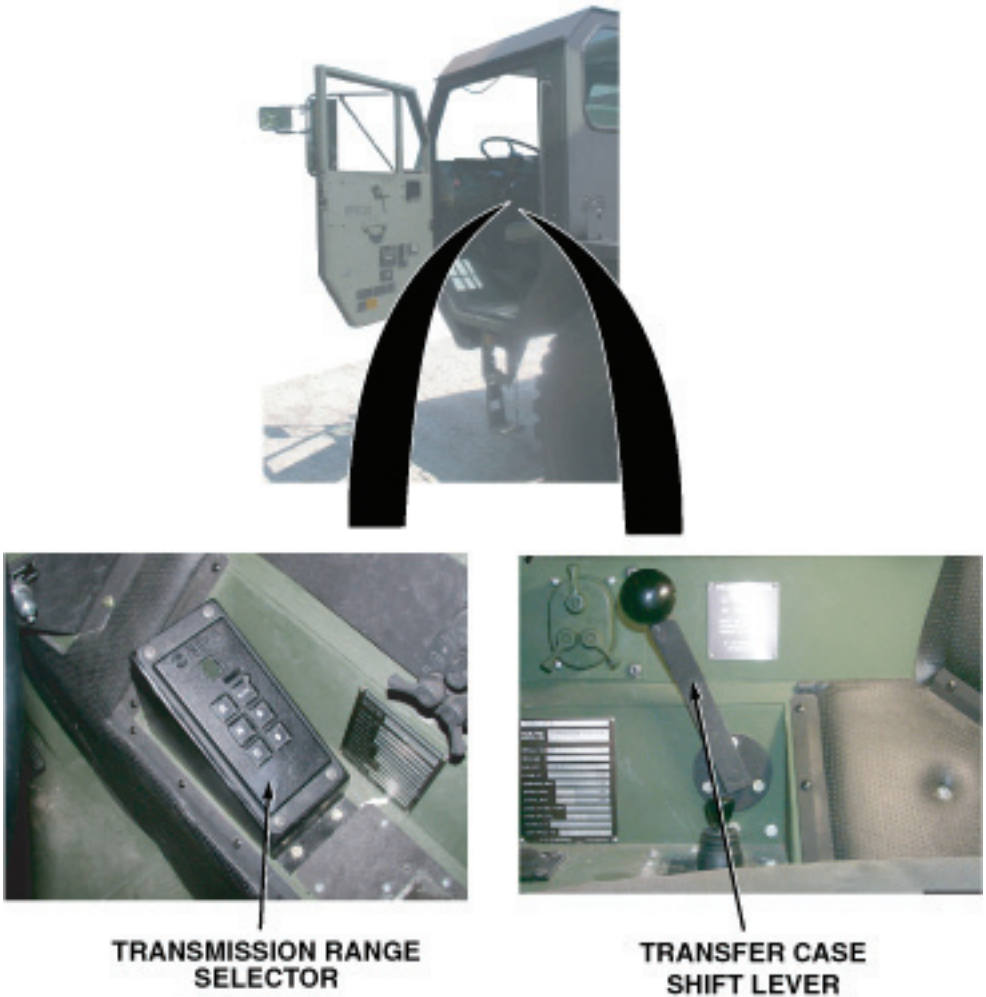

Figure 2.

CONDITION/INDICATION

Does transfer case shift lever shift when transmission is shifted from Neutral (N) to Reverse (R)?

DECISION

- No - Test 3 - Is shift cable free of mud and debris?
 Yes - Problem corrected.

TEST 3 - Is shift cable free of mud and debris?

1. Turn engine OFF. (WP 0057)
2. Check shift cable for mud and/or debris.

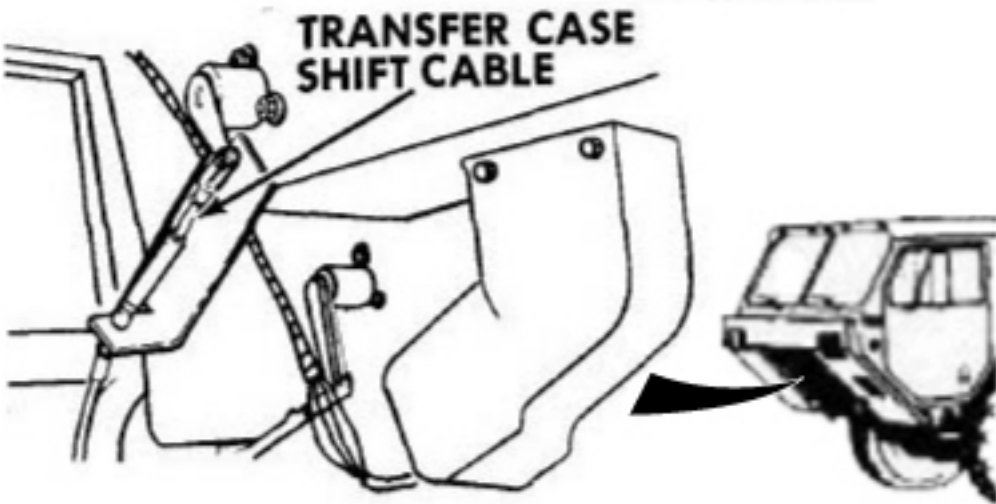

Figure 3.

3. If needed, clean shift cable. (WP 0154)

CONDITION/INDICATION

Is shift cable free of mud and debris?

DECISION

- Dirty - Test 4 - Does transfer case shift lever shift normally?
 Clean - Notify Supervisor.

TEST 4 - Does transfer case shift lever shift normally?

1. Start engine. (WP 0044)
 - a. Test drive vehicle.
2. Attempt to shift transfer case. (WP 0048)

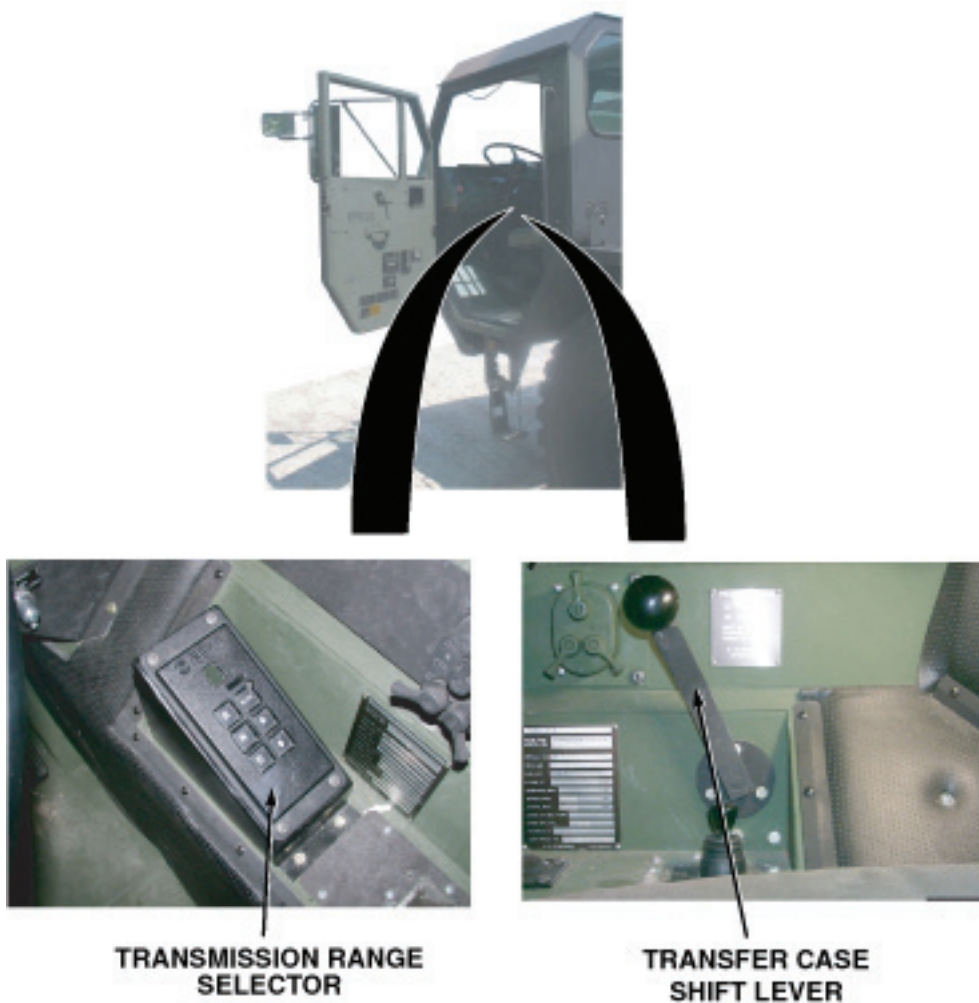

Figure 4.

3. Turn engine OFF. (WP 0057)

CONDITION/INDICATION

Does transfer case shift lever shift normally?

DECISION

No - Notify Supervisor.
Yes - Problem corrected.

END OF WORK PACKAGE

OPERATOR MAINTENANCE
TRANS TEMP GAUGE INDICATES OVERHEATING DURING NORMAL OPERATION

INITIAL SETUP:

Equipment Condition

Engine OFF. (WP 0057)

Equipment Condition - Continued

Parking brakes applied. (WP 0056)

Wheels chocked. (WP 0077)

TROUBLESHOOTING PROCEDURE

TRANS TEMP GAUGE INDICATES OVERHEATING DURING NORMAL OPERATION

TEST 1 - Is transmission fluid at proper operating level?

1. Check transmission fluid level. (WP 0147)

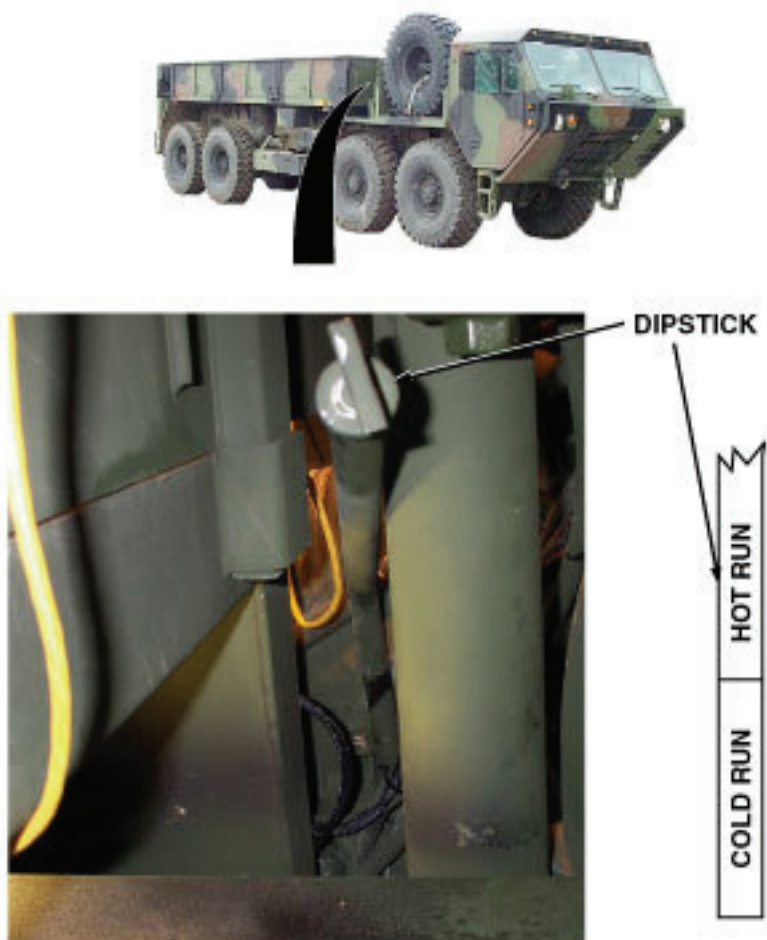

Figure 1.

2. If transmission fluid is low, add transmission fluid. (WP 0147)

CONDITION/INDICATION

Is transmission fluid at proper operating level?

DECISION

Transmission fluid was high. - Notify Supervisor. Test 2 - Does TRANS TEMP gauge indicate overheating during normal operation?

Transmission fluid was at proper level. - Notify Supervisor.

TEST 2 - Does TRANS TEMP gauge indicate overheating during normal operation?

1. Start engine. (WP 0044)
2. Test drive vehicle.

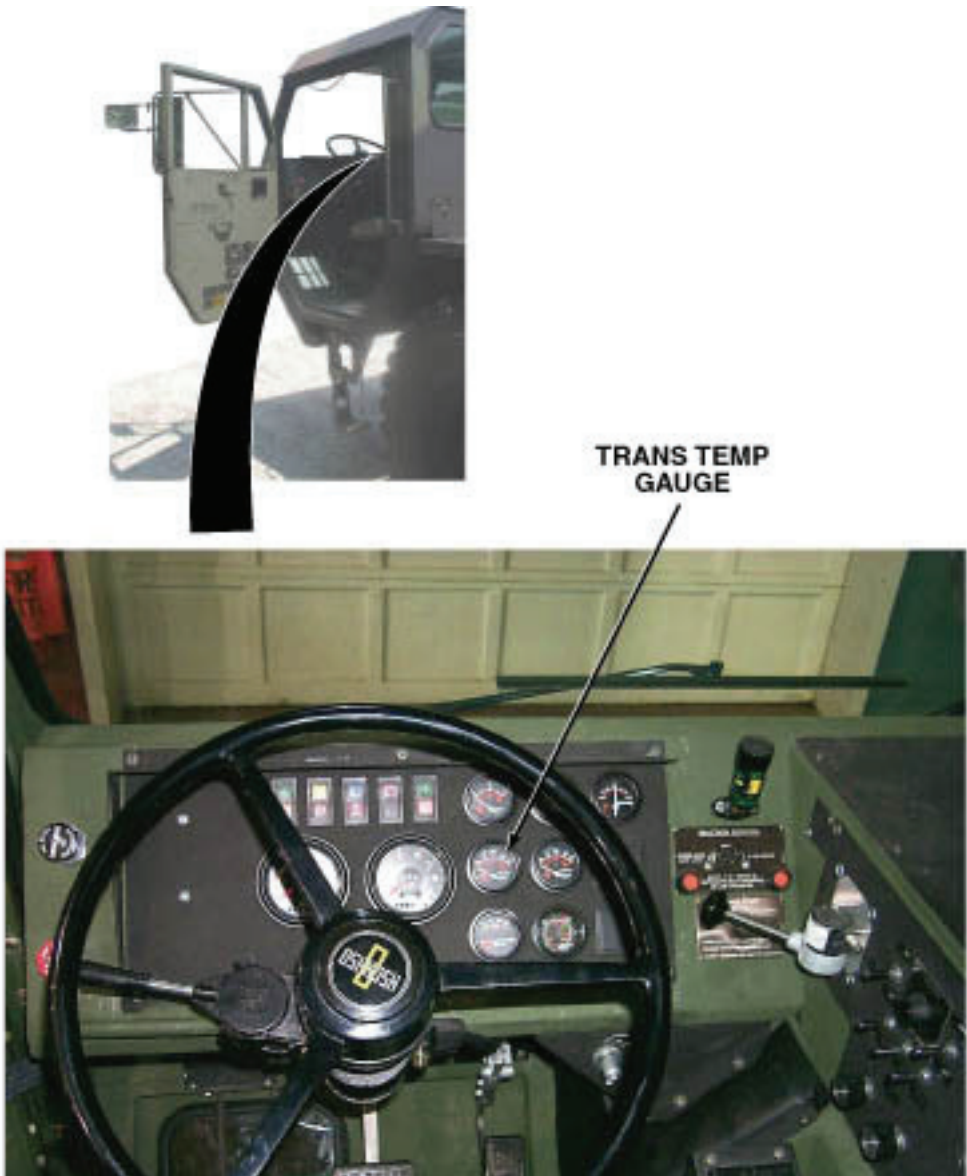

Figure 2.

CONDITION/INDICATION

Does TRANS TEMP gauge indicate overheating during normal operation?

DECISION

Overheating - Notify Supervisor.

Correct temperature - Problem corrected.

END OF WORK PACKAGE

**OPERATOR MAINTENANCE
WHEEL WOBBLES**

INITIAL SETUP:**Equipment Condition**

Engine OFF. (WP 0057)

Equipment Condition - Continued

Parking brakes applied. (WP 0056)

Wheels chocked. (WP 0077)

**TROUBLESHOOTING PROCEDURE
WHEEL WOBBLES****TEST 1 - Are any lugnuts loose, missing or broken?**

1. Check wheels for loose, missing or broken lugnuts.



Figure 1.

CONDITION/INDICATION

Are any lugnuts loose, missing or broken?

DECISION

No - Tighten or replace lugnut(s). (WP 0155)

Yes - Test 2 - Are any of the wheels bent?

TEST 2 - Are any of the wheels bent?

1. Check to see if any of the wheels are bent.

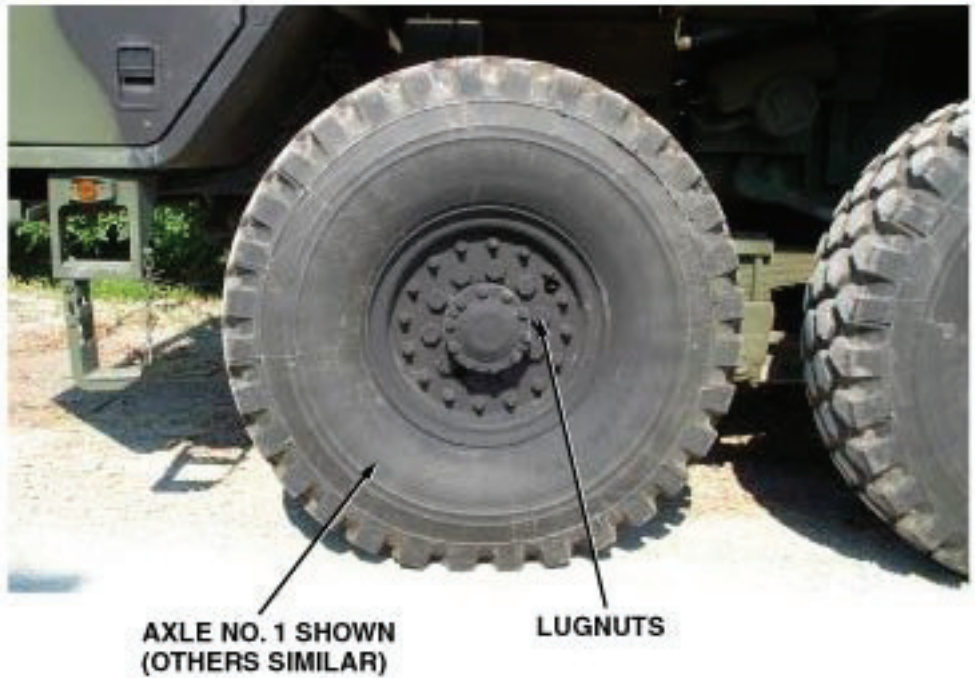

Figure 2.

CONDITION/INDICATION

Are any of the wheels bent?

DECISION

Wheel bent - Replace damaged wheel(s). (WP 0155)

Wheels OK - Notify Supervisor.

TEST 3 - Do any of the wheels wobble?

1. Start engine. (WP 0044)
2. Test drive vehicle.

CONDITION/INDICATION

Do any of the wheels wobble?

DECISION

Wheel wobbles - Notify Supervisor.

Wheel OK - Notify Supervisor.

END OF WORK PACKAGE

**OPERATOR MAINTENANCE
TIRES WORN UNEVENLY OR EXCESSIVELY**

INITIAL SETUP:**Equipment Condition**

Engine OFF. (WP 0057)

Equipment Condition - Continued

Parking brakes applied. (WP 0056)

Wheels chocked. (WP 0077)

**TROUBLESHOOTING PROCEDURE
TIRES WORN UNEVENLY OR EXCESSIVELY**

TEST 1 - Are tires inflated to proper pressure for road condition?**WARNING**

Tire air pressure must be checked properly. Failure to comply may result in injury or death to personnel.

NOTE

- Inflate tires only when they are cool. Inflate to proper pressure for road condition.
- Tire tread is non-directional. Vehicle operation is not affected by direction of traction bars.

1. Check tires for proper inflation. (WP 0148)

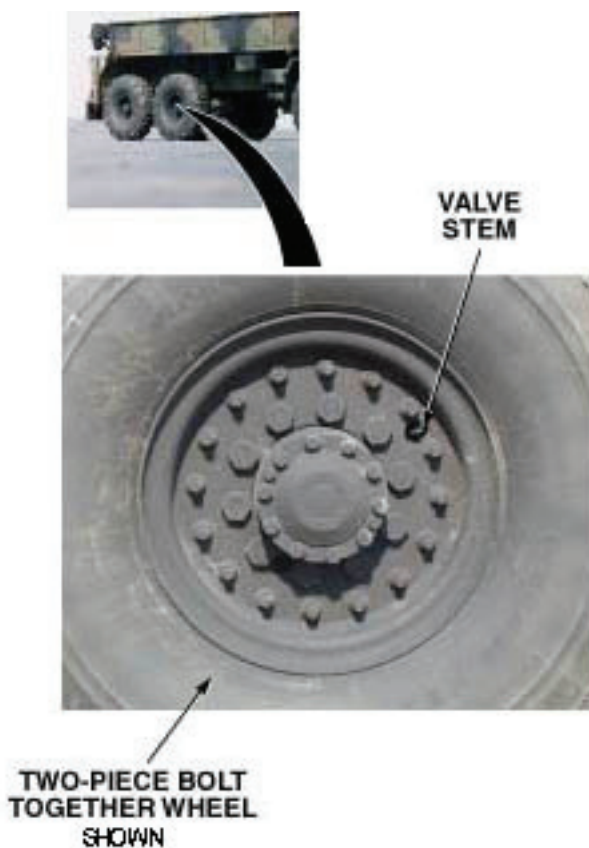

Figure 1.

2. If tires are improperly inflated, inflate or deflate to proper pressure.

CONDITION/INDICATION

Are tires inflated to proper pressure for road condition?

DECISION

Improperly inflated - Notify Supervisor.

Inflation OK - Notify Supervisor.

END OF WORK PACKAGE

CHAPTER 4

PREVENTIVE
MAINTENANCE
CHECKS AND
SERVICES (PMCS)

OPERATOR MAINTENANCE INTRODUCTION - PREVENTIVE MAINTENANCE

PMCS INTRODUCTION

This section contains PMCS requirements for HEMTT series vehicles. The PMCS tables contain checks and services necessary to ensure that the vehicle is ready for operation. Using PMCS tables, perform maintenance at specified intervals.

MAINTENANCE FORMS AND RECORDS

Every mission begins and ends with paperwork. There is not much of it, but it must be kept up. The filled out forms and records have several uses. They are a permanent record of services, repairs, and modifications made on the vehicle; they are reports to unit maintenance and to your Commander; and they serve as a checklist to find out what is wrong with the vehicle after its last use, and whether those faults have been fixed. For the information needed on forms and records, refer to DA PAM 750-8. (WP 0161)

PREVENTIVE MAINTENANCE CHECKS AND SERVICES

- Do the before (B) PREVENTIVE MAINTENANCE just before operating vehicle. Pay attention to the CAUTIONS and WARNINGS.
- Do the during (D) PREVENTIVE MAINTENANCE while vehicle and/or its component systems are in operation. Pay attention to the CAUTIONS and WARNINGS.
- Do the after (A) PREVENTIVE MAINTENANCE right after operating vehicle. Pay attention to the CAUTIONS and WARNINGS.
- Do the (W) PREVENTIVE MAINTENANCE weekly. Pay attention to the CAUTIONS and WARNINGS.
- Do the (M) PREVENTIVE MAINTENANCE once a month. Pay attention to the CAUTIONS and WARNINGS.
- If something does not work, troubleshoot and notify the supervisor.
- Always do PREVENTIVE MAINTENANCE in the same order until it gets to be habit. Once practiced, problems can be spotted in a hurry.
- If something looks wrong and cannot be fixed right then, write it on DA Form 2404 (WP 0161) or DA Form 5988-E. (WP 0161) If something seems seriously wrong, report it to field level maintenance RIGHT NOW.
- When doing PREVENTIVE MAINTENANCE, take along the tools needed and a rag or two to make all the checks.

GENERAL MAINTENANCE PROCEDURE

- **Cleanliness:** Dirt, grease, oil, and debris only get in the way and may cover up a serious problem. Use solvent cleaning compound (WP 0164, Table 1, Item 6, 7, 8, 9, 10, 11) on all metal surfaces and soapy water on rubber.
- **Bolts, Nuts, and Screws:** Check bolts, nuts, and screws for obvious looseness, missing, bent, or broken condition and tighten or replace as necessary. They cannot all be checked with a tool, of course, but look for chipped paint, bare metal, or rust around bolt heads.
- **Welds:** Look for loose or chipped paint, rust, or gaps where parts are welded together. If a bad weld is found, have it repaired.
- **Electric Wires and Connectors:** Look for cracked or broken insulation, bare wires, and loose or broken connectors. Tighten loose connectors and make sure wires are in good shape.
- **Hydraulic Lines and Fittings:** Look for wear, damage, and leaks, and make sure clamps and fittings are tight. Wet spots show leaks, of course, but a stain around a fitting or connector can indicate a leak. If a connector or fitting is loose, tighten it. If something is broken or worn out, repair or replace per applicable procedure.
- **Damage is defined as:** Any conditions that affect safety or would render the vehicle unserviceable for mission requirements.

FLUID LEAKAGE

It is necessary to know how fluid leakage affects the status of fuel, oil, coolant, and the hydraulic systems. The following are definitions of types/classes of leakage necessary to know in order to determine the status of the vehicle.

NOTE

Equipment operation is allowable with minor leakage (Class I or II). Consideration must be given to the fluid capacity in the item/system being checked/inspected. When in doubt, notify the supervisor. When operating with Class I or II leaks, continue to check fluid levels as required in the PMCS. Class III leaks should be repaired per applicable procedure.

Class I : Seepage of fluid (as indicated by wetness or discoloration) not great enough to form drops.

Class II: Leakage of fluid great enough to form drops but not enough to cause drops to drip from item being checked/inspected.

Class III: Leakage of fluid great enough to form drops that fall from the item being checked/inspected.

PREVENTIVE MAINTENANCE CHECKS AND SERVICES (PMCS)

Prior to performing your PMCS, check with your PLL clerk to verify that the latest publications are being used.

PREVENTIVE MAINTENANCE CHECKS AND SERVICES (PMCS) - Continued

Listed below are the sections of the PMCS.

PMCS - BEFORE (WP 0145)

PMCS - DURING (WP 0146)

PMCS - AFTER (WP 0147)

PMCS - WEEKLY (WP 0148)

PMCS - MONTHLY (WP 0150)

PMCS - SEMIANNUAL (WP 0149)

Vehicles designated or dispatched to transport Class A or B ammunition, explosives, poisons, or radioactive yellow III materials over public highways require more stringent inspections.

Daily Walk Around PMCS Diagram. This routing diagram will be of help to complete the B, D, or A PMCS. It shows the vehicle PMCS routing track, which matches the sequence of PMCS to be performed.

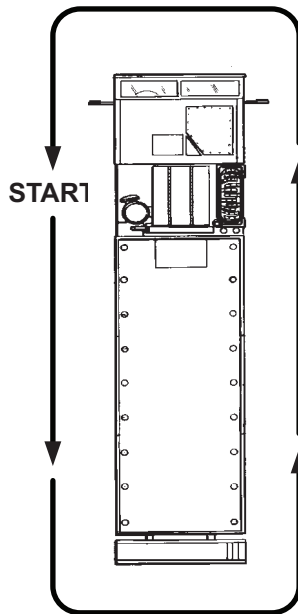

Figure 1.

END OF WORK PACKAGE

**OPERATOR MAINTENANCE
BEFORE - PREVENTIVE MAINTENANCE**

INITIAL SETUP:

Tools and Special Tools

Gloves, Leather (WP 0163, Table 2)

Table 1. PMCS - BEFORE



Item No.	Interval	Item to be Checked or Serviced	Procedure	Equipment Not Ready/ Available If:
			<p style="text-align: center;">WARNING</p>  <p>Do not start engine or move vehicle when personnel are under vehicle or working on brake lines. Failure to comply may result in injury or death to personnel.</p> <p style="text-align: center;">WARNING</p>  <p>Ensure engine is OFF and eye protection is worn when checking for leaks. Failure to comply may result in injury or death to personnel.</p>	

Table 1. PMCS - BEFORE - Continued

Item No.	Interval	Item to be Checked or Serviced	Procedure	Equipment Not Ready/ Available If:
			<p style="text-align: center;">NOTE</p> <p>Perform Operator's Before, After, and Weekly PMCS checks if:</p> <ul style="list-style-type: none"> • You are the assigned driver but have not operated the vehicle since the last weekly inspection. • You are operating the vehicle for the first time. <p style="text-align: center;">NOTE</p> <ul style="list-style-type: none"> • Clean all lubrication points with cleaning compound, solvent and allow to dry prior to servicing. • When using a grease gun, apply lubricant to the fitting until clean lubricant squeezes out of the part being lubricated. • Always refer to lubrication instructions (WP 0151) to ensure equipment has correct lubricants appropriate to operating environment (expected continuous temperatures). If not, remove/drain and reapply/refill equipment with appropriate lubricants for operating environment as 	

Table 1. PMCS - BEFORE - Continued

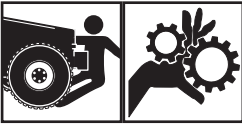
Item No.	Interval	Item to be Checked or Serviced	Procedure	Equipment Not Ready/ Available If:
1	Before	Driver Side Exterior	<p>prescribed in lubrication instructions. (WP 0151)</p> <p style="text-align: center;">NOTE</p> <ul style="list-style-type: none"> • Diesel engine slobber is an inherent condition of diesel engines. When diesel engines are allowed to idle for prolonged periods of time, this characteristic may be interpreted as a Class III leak. Check engine oil level. If there is any doubt, contact your supervisor or field level maintenance. • If leakage is detected, further investigation is needed to determine the location and cause of the leak. If there is any doubt, contact your supervisor or field level maintenance. <p>1. Check underneath entire length of driver side of vehicle for fluid and air leaks.</p>	Any fuel leak, Class III leak (other than fuel), or air lines/fittings leaking or damaged.

Table 1. PMCS - BEFORE - Continued

Item No.	Interval	Item to be Checked or Serviced	Procedure	Equipment Not Ready/ Available If:
			<p>2. Visually check driver side of vehicle for obvious damage that would impair operation.</p> <p style="text-align: center;">WARNING</p>  <ul style="list-style-type: none"> • During normal vehicle operation, cooling system can become very hot. Allow cooling system to cool prior to servicing. Failure to comply may result in injury to personnel. • Use extreme care when removing radiator cap. Sudden release of pressure can cause a steam flash. Slowly loosen radiator cap to the first stop to relieve pressure before removing radiator cap completely. Failure to comply may result in injury to personnel. • Use a clean, thick waste cloth or like material to remove radiator cap. 	<p>Any damage that would impair operation.</p>

Table 1. PMCS - BEFORE - Continued

Item No.	Interval	Item to be Checked or Serviced	Procedure	Equipment Not Ready/ Available If:
2	Before	Radiator	<p>Avoid using gloves. If hot water soaks through gloves, personnel could be burned. Failure to comply may result in injury to personnel.</p> <p>Remove radiator cap and check radiator coolant level. Coolant level should be up to bottom of filler neck. If fluid level is low, fill to appropriate level.</p>	Coolant is low.

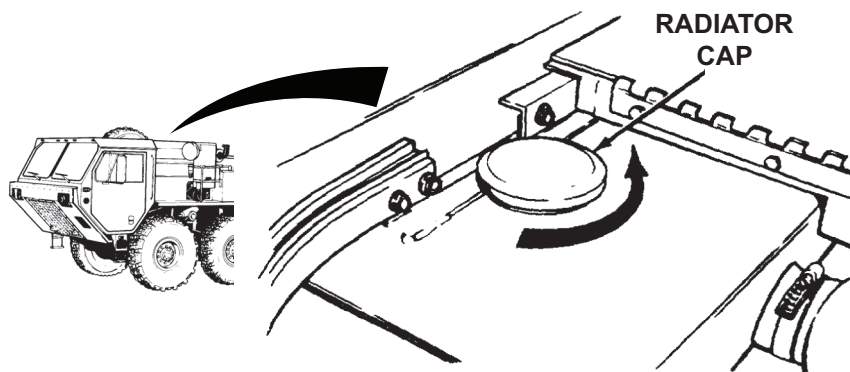

Figure 1.

WARNING



Do not operate a vehicle with a tire in an over-inflated or un-

Table 1. PMCS - BEFORE - Continued

Item No.	Interval	Item to be Checked or Serviced	Procedure	Equipment Not Ready/ Available If:
3	Before	Driver Side Tires	<p>der-inflated condition, or with a questionable defect. Failure to comply may result in injury or death to personnel and damage to equipment.</p> <p style="text-align: center;">NOTE</p> <ul style="list-style-type: none"> • A tire is bad or in need of repair if the bead, sidewall, and tread areas show signs of damage. • Remember that this process requires you to make judgment calls and the goal is to safely maintain equipment in top quality conditions. <p>Check for correct air pressure on each driver side tire and service tire (WP 0158) as required.</p>	Tire missing, deflated, or un-serviceable.
4	Before	Engine	<ol style="list-style-type: none"> 1. Check engine oil level on dipstick. 	

Table 1. PMCS - BEFORE - Continued

Item No.	Interval	Item to be Checked or Serviced	Procedure	Equipment Not Ready/ Available If:

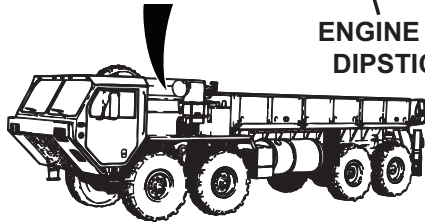
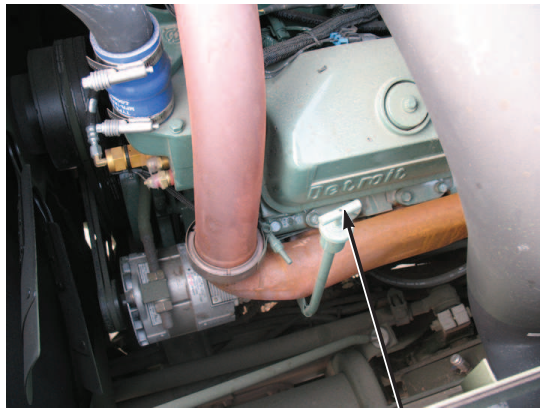

**ENGINE OIL
DIPSTICK**

Figure 2.

NOTE

Engine oil level should be between ADD and FULL mark on dipstick.

- a. Add engine oil as required. (WP 0151)

Table 1. PMCS - BEFORE - Continued

Item No.	Interval	Item to be Checked or Serviced	Procedure	Equipment Not Ready/ Available If:
5	Before	24V Battery Disconnect Switch	<p>b. Drain excess engine oil as required, or notify field level maintenance.</p> <p>Check 24V battery disconnect switch for proper operation. (WP 0079)</p>	24V battery disconnect switch inoperative.

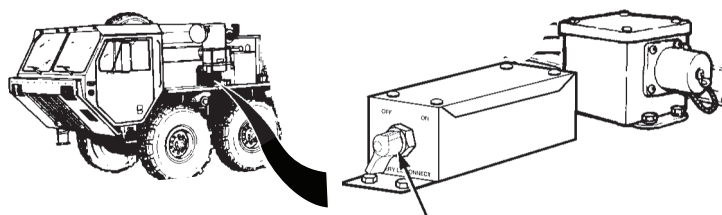

24V BATTERY DISCONNECT SWITCH

Figure 3.

6	Before	Rear of Vehicle	Visually check rear of vehicle for obvious damage that would impair operation.	Any damage that would impair operation.
7	Before	Cargo Body	1. Check that side panels, and front/rear end panels are not bent, broken, and have no broken welds.	Any side panel or end panel is missing, bent, broken, or has

Table 1. PMCS - BEFORE - Continued

Item No.	Interval	Item to be Checked or Serviced	Procedure	Equipment Not Ready/ Available If:
				a broken weld.

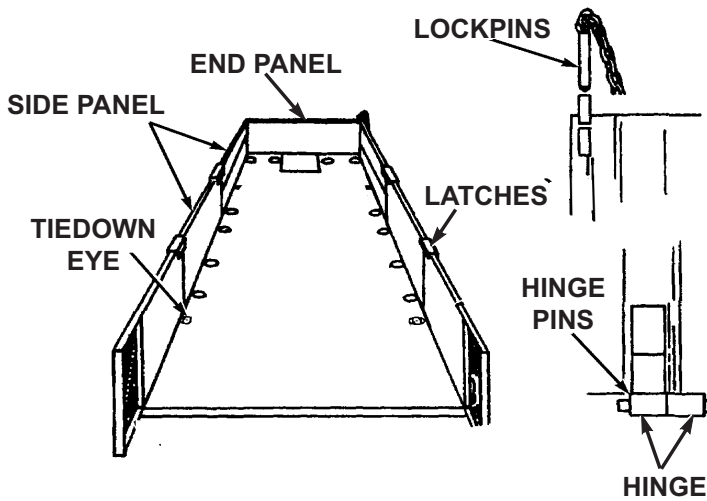

Figure 4.

		<ol style="list-style-type: none"> 2. Check for broken latches and missing lockpins. 3. Check for broken, bent, or damaged hinge pins and tiedown eyes. 	<p>A latch is broken or a lockpin is missing.</p> <p>Any hinge pin or tiedown eye is missing, broken, or bent.</p>
--	--	---	--

Table 1. PMCS - BEFORE - Continued

Item No.	Interval	Item to be Checked or Serviced	Procedure	Equipment Not Ready/ Available If:
			<p>4. Check for broken or binding hinges.</p> <p style="text-align: center;">NOTE</p> <p>Operation of vehicle with bent, broken, or missing cargo body screws may violate AR 385-55.</p> <p>5. Check that cargo body mounting screws are not broken, cracked, or missing.</p>	<p>Hinges are missing, broken, or have broken welds.</p> <p>One or more screws are broken, cracked, or missing.</p>

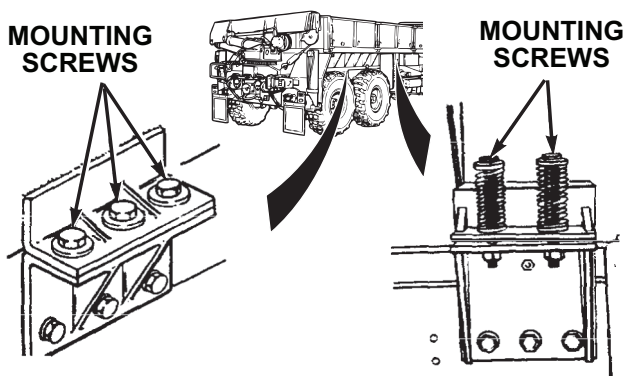
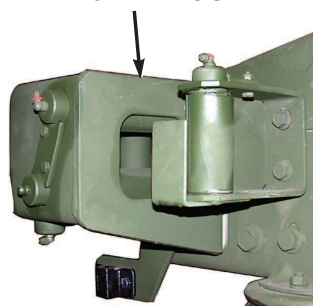

Figure 5.

Table 1. PMCS - BEFORE - Continued

Item No.	Interval	Item to be Checked or Serviced	Procedure	Equipment Not Ready/ Available If:
8	Before	Self-Recovery Winch (SRW)	1. Inspect self-recovery winch for obvious damage.	Self-recovery winch unserviceable.

REAR CABLE GUIDE



FRONT CABLE GUIDE

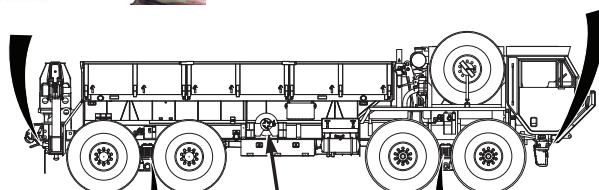
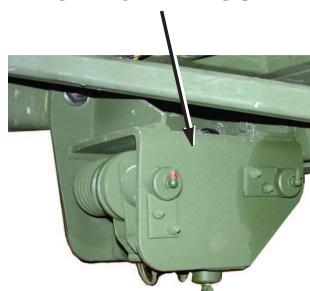

REAR TENSIONER

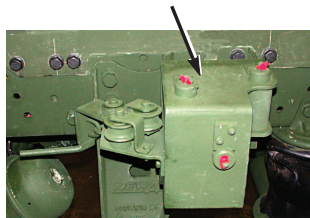

SELF-RECOVERY WINCH

FRONT TENSIONER

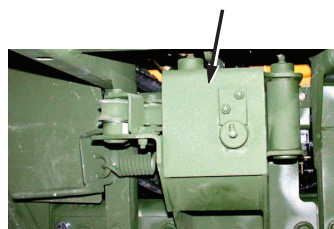

Figure 6.

Table 1. PMCS - BEFORE - Continued

Item No.	Interval	Item to be Checked or Serviced	Procedure	Equipment Not Ready/ Available If:
9	Before	Wheel Chocks	<p>2. Inspect front cable guide for any loose or missing parts and any obvious damage.</p> <p>3. Inspect front tensioner for loose or missing parts and any obvious damage.</p> <p>4. Inspect rear tensioner for loose or missing parts and any obvious damage.</p> <p>5. Inspect rear cable guide for loose or missing parts and any obvious damage</p> <p>Ensure vehicle is equipped with four wheel chocks.</p>	<p>Front cable guide has loose or missing parts, or is unserviceable.</p> <p>Front tensioner has loose or missing parts, or is unserviceable.</p> <p>Rear tensioner has loose or missing parts, or is unserviceable.</p> <p>Rear cable guide has loose or missing parts, or is unserviceable.</p> <p>Vehicle is equipped with less than four</p>

Table 1. PMCS - BEFORE - Continued

Item No.	Interval	Item to be Checked or Serviced	Procedure	Equipment Not Ready/ Available If:
10	Before	Passenger Side Exterior	<p style="text-align: center;">NOTE</p> <ul style="list-style-type: none"> • Diesel engine slobber is an inherent condition of diesel engines. When diesel engines are allowed to idle for prolonged periods of time, this characteristic may be interpreted as a Class III leak. Check engine oil level. If there is any doubt, contact your supervisor or field level maintenance. • If leakage is detected, further investigation is needed to determine the location and cause of the leak. If there is any doubt, contact your supervisor or field level maintenance. <p>1. Check underneath entire length of driver side of vehicle for fluid and air leaks.</p>	<p>wheel chocks.</p> <p>Any fuel leak, Class III leak (other than fuel), or air lines/fittings leaking or damaged.</p>

Table 1. PMCS - BEFORE - Continued

Item No.	Interval	Item to be Checked or Serviced	Procedure	Equipment Not Ready/ Available If:
			<p>2. Visually check driver side of vehicle for obvious damage that would impair operation.</p> <p style="text-align: center;">WARNING</p> <div style="text-align: center;">  </div> <p>Fuel is very flammable and can explode easily. Keep fuel away from open fire and keep fire extinguisher within easy reach when working with fuel. Do not work on fuel system when engine is hot. Fuel can be ignited when engine is hot. When working with fuel, post signs that read NO SMOKING WITHIN 50 FEET OF VEHICLE. Failure to comply may result in injury or death to personnel.</p> <p style="text-align: center;">NOTE</p> <ul style="list-style-type: none"> • Drain fuel into suitable container. 	<p>Any damage that would impair operation.</p>

Table 1. PMCS - BEFORE - Continued

Item No.	Interval	Item to be Checked or Serviced	Procedure	Equipment Not Ready/ Available If:
11	Before	Fuel/ Water Separator	<ul style="list-style-type: none"> • Operation of vehicle with malfunctioning fuel/water separator may violate AR 385-55. (WP 0161) <ol style="list-style-type: none"> 1. Check for level of water in bowl of fuel/water separator. If there is water, turn thumb nut on bottom of bowl to open contaminant drain valve. Keep drain open until only pure fuel is flowing out of drain tube. Close drain valve by turning thumb nut. 	

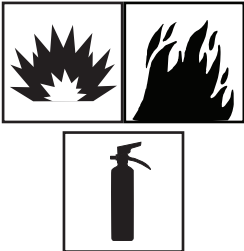
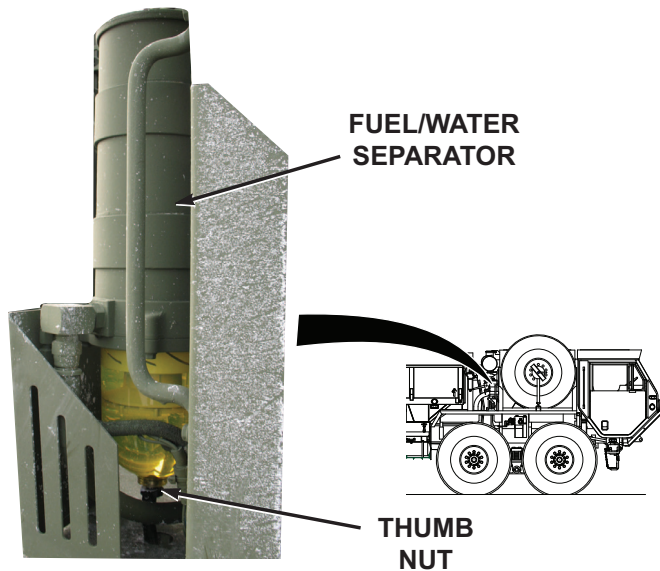

Figure 7.

Table 1. PMCS - BEFORE - Continued

Item No.	Interval	Item to be Checked or Serviced	Procedure	Equipment Not Ready/ Available If:
			<p>2. Check fuel/water separator for leaks and damage.</p> <p style="text-align: center;">WARNING</p> <div style="text-align: center;">  </div> <p>Do not operate a vehicle with a tire in an over-inflated or under-inflated condition, or with a questionable defect. Failure to comply may result in injury or death to personnel and damage to equipment.</p> <p style="text-align: center;">NOTE</p> <ul style="list-style-type: none"> • Remember that a tire in storage (spare) can be flat but not look like it. The HEMTT tire sidewalls can support the wheel. Don't be fooled. • A tire is bad or in need of repair if the bead, sidewall, and tread areas show signs of damage. • Remember that this process requires you to make judgment calls and the goal is to safely maintain equipment in top quality conditions. 	<p>Any fuel leaking.</p>

Table 1. PMCS - BEFORE - Continued

Item No.	Interval	Item to be Checked or Serviced	Procedure	Equipment Not Ready/ Available If:
12	Before	Passenger Side Tires (including spare tire)	<p>1. Check for correct air pressure on each passenger side tire (including spare tire) and service tire (WP 0158) as required.</p> <p style="text-align: center;">WARNING</p> <div style="text-align: center;">  </div> <p>Ensure proper inspection and maintenance procedures of seat belt systems are adhered to. Failure to comply may result in injury or death to personnel.</p> <p style="text-align: center;">NOTE</p> <p>Vehicle operation with inoperative seat belts may violate AR 385-55. (WP 0161)</p>	Tire missing, deflated, or un-serviceable.
13	Before	Seat Belts	<p>1. Check seat belt strap webbing wear, tears, fraying, etc.</p>	Webbing is cut, frayed or excessively worn.

Table 1. PMCS - BEFORE - Continued

Item No.	Interval	Item to be Checked or Serviced	Procedure	Equipment Not Ready/ Available If:
----------	----------	--------------------------------	-----------	------------------------------------

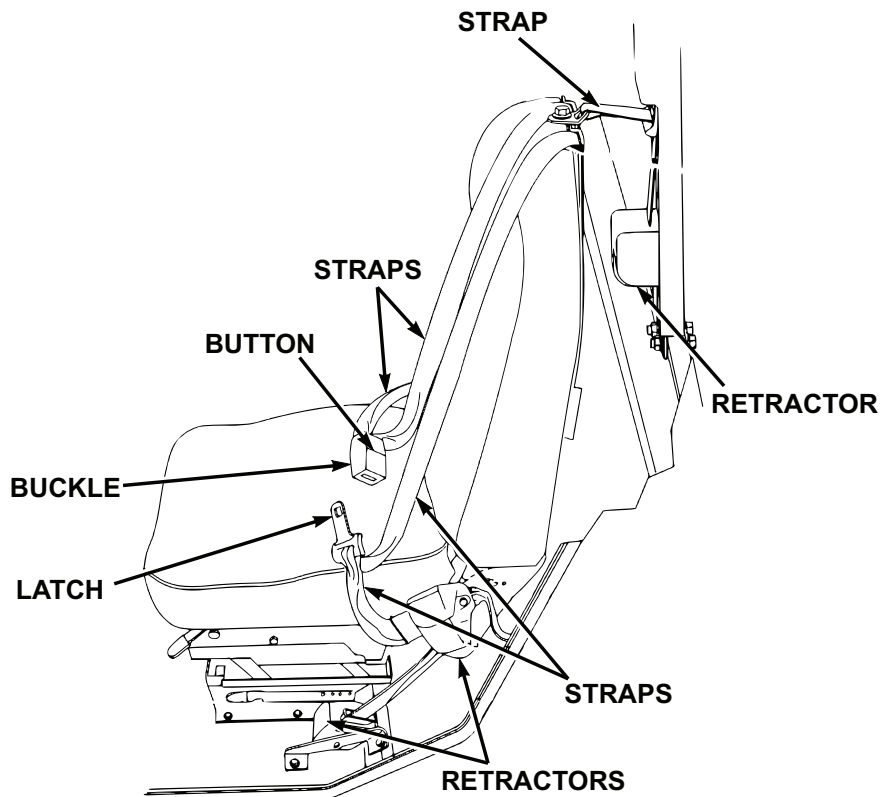

Figure 8.

2. Check latch and buckle for proper operation, wear, deformation, damage, and broken casing.

Buckle/latch does not engage with a solid-sounding "click" and/or does not

Table 1. PMCS - BEFORE - Continued

Item No.	Interval	Item to be Checked or Serviced	Procedure	Equipment Not Ready/ Available If:
14	Before	Seats	<p>3. Check all seat belt retractors are not locked up and pay out/reel in webbing straps properly.</p> <p>4. Check all seat belt mounting hardware for looseness and other damage.</p> <p>Check operation of seat adjusting mechanisms. (WP 0023)</p>	<p>release freely when button is pushed. Molded plastic around buckle/latch is deformed, cracked, or broken.</p> <p>Retractor(s) do not operate properly, or retractor cover(s) are cracked/ broken.</p> <p>Hardware is loose, missing, rusted, corroded, or damaged.</p> <p>Seat adjustment mechanism broken or missing.</p>

Table 1. PMCS - BEFORE - Continued

Item No.	Interval	Item to be Checked or Serviced	Procedure	Equipment Not Ready/ Available If:
----------	----------	--------------------------------	-----------	------------------------------------

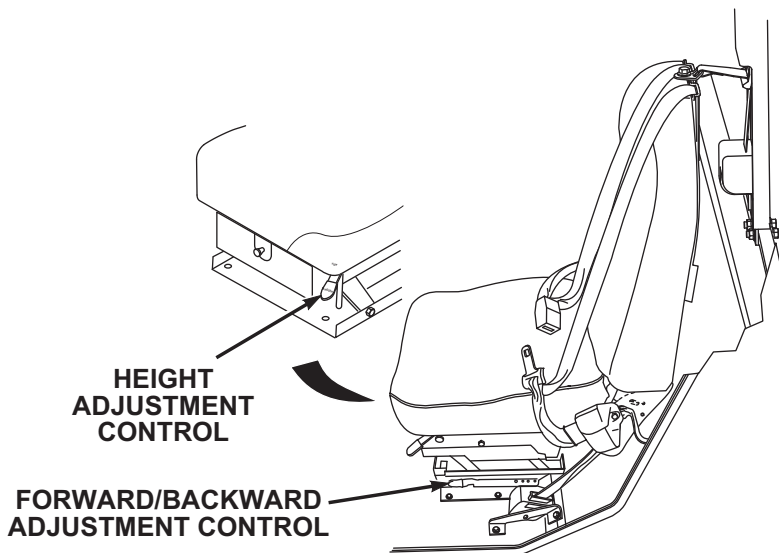

Figure 9.

15	Before	Fire Extinguisher (cab)	1. Check for missing or damaged fire extinguisher.	Fire extinguisher missing or damaged.
----	--------	-------------------------	--	---------------------------------------

Table 1. PMCS - BEFORE - Continued

Item No.	Interval	Item to be Checked or Serviced	Procedure	Equipment Not Ready/ Available If:

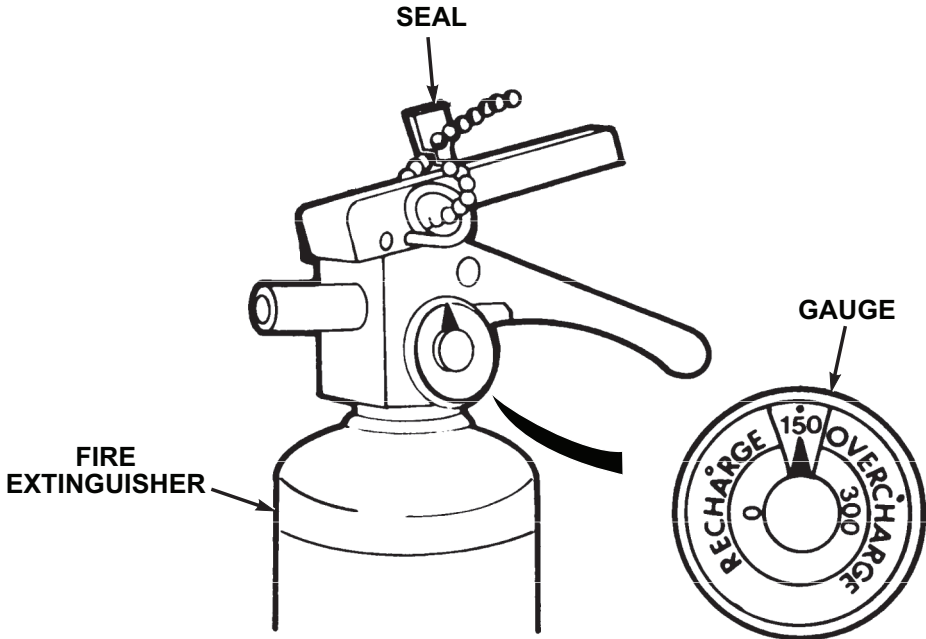

Figure 10.

		<ol style="list-style-type: none"> 2. Check gauge for proper pressure of about 150 psi (1034 kPa). 3. Ensure fire extinguisher mounting is secure. 	<p>Pressure gauge needle in RECHARGE area.</p>
--	--	--	--

Table 1. PMCS - BEFORE - Continued

Item No.	Interval	Item to be Checked or Serviced	Procedure	Equipment Not Ready/ Available If:
			<p>4. Check for damaged or missing seal.</p> <p style="text-align: center;">NOTE</p> <ul style="list-style-type: none"> • Complete all start engine (WP 0044) procedures, and comply with all notes, cautions, and warnings within that procedure before completing the PMCS checks below. • Once all start engine (WP 0044) procedures are completed, engine should be kept running for the remaining PMCS checks. 	<p>Seal broken or missing.</p>
16	Before	Engine	<p>Start engine. (WP 0044)</p> <p style="text-align: center;">NOTE</p> <p>Check the instruments listed below for damage, operation, and condition.</p>	<p>Engine fails to start.</p>
17	Before	Instruments	<p>1. Engine OIL PRESS gauge.</p>	<p>Engine OIL PRESS gauge is in-operative.</p>

Table 1. PMCS - BEFORE - Continued

Item No.	Interval	Item to be Checked or Serviced	Procedure	Equipment Not Ready/ Available If:
----------	----------	--------------------------------	-----------	------------------------------------

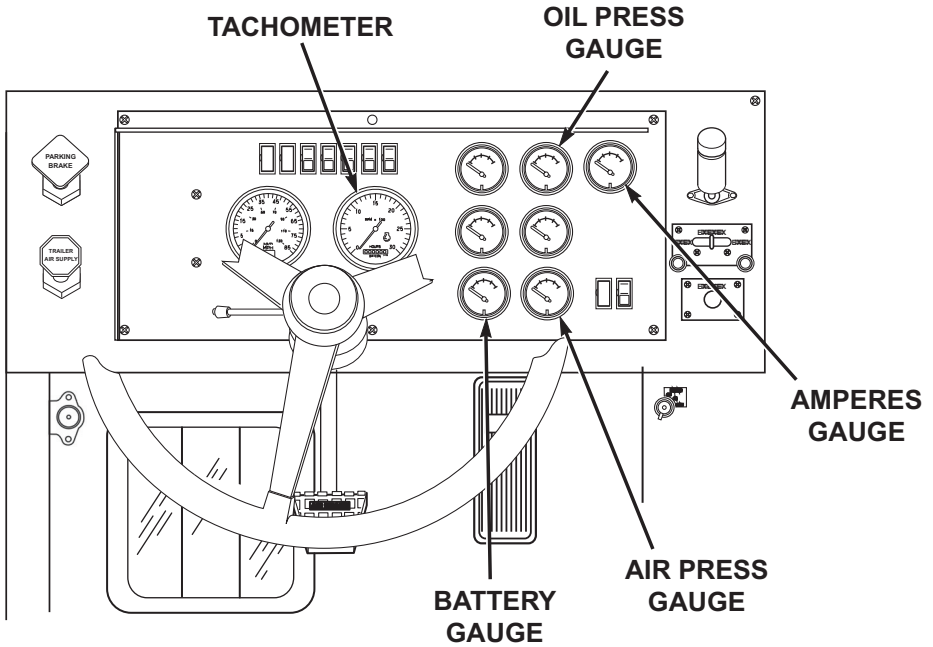

Figure 11.

	2. Tachometer.		Tachometer is inoperative or indicates less than 600 rpm or more than 800 rpm at idle after engine has been properly warmed up
--	----------------	--	--

Table 1. PMCS - BEFORE - Continued

Item No.	Interval	Item to be Checked or Serviced	Procedure	Equipment Not Ready/ Available If:
			<p>3. BATTERY gauge.</p> <p>4. AMPERES gauge.</p> <p style="text-align: center;">NOTE</p> <p>Air pressure buzzer will sound anytime low air indicator is illuminated. Ensure low air indicator and buzzer activate when air pressure falls below 60 to 75 psi (414 to 517 kPa) in either front or rear air system.</p>	<p>(start engine (WP 0044) procedure completed).</p> <p>BATTERY gauge is inoperative, or indicates less than 24 VDC or more than 30 VDC with engine running.</p> <p>AMPERES gauge is inoperative, or shows a negative reading with engine running.</p>

Table 1. PMCS - BEFORE - Continued

Item No.	Interval	Item to be Checked or Serviced	Procedure	Equipment Not Ready/ Available If:
			<p>5. AIR PRESS gauge.</p> <p>6. Air filter restriction indicator.</p>	<p>AIR PRESS gauge is inoperative or indicates either system is below 60 psi (414 kPa) after engine has been properly warmed up (start engine (WP 0044) procedure completed). Low air pressure indicator and/or buzzer remain on, or do not operate.</p> <p>Air filter restriction indicator inoperative, cracked, or unserviceable.</p>

Table 1. PMCS - BEFORE - Continued

Item No.	Interval	Item to be Checked or Serviced	Procedure	Equipment Not Ready/ Available If:
----------	----------	--------------------------------	-----------	------------------------------------

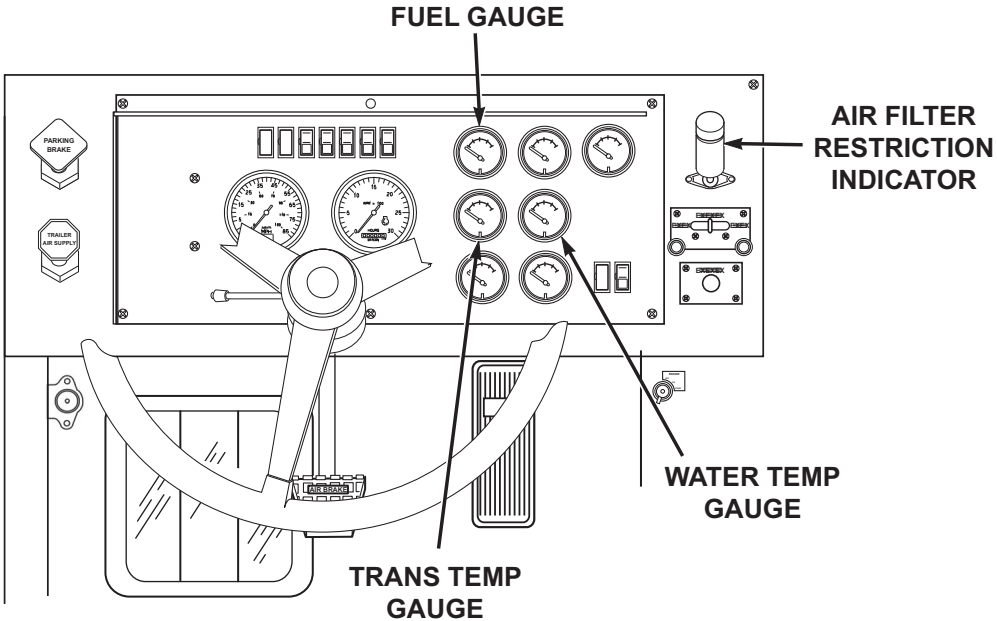

Figure 12.

NOTE

Several minutes are required for engine to warm up so an accurate reading can be taken.

7. WATER TEMP gauge.

WATER TEMP gauge is inoperative, or indicates less than

Table 1. PMCS - BEFORE - Continued

Item No.	Interval	Item to be Checked or Serviced	Procedure	Equipment Not Ready/ Available If:
			<p style="text-align: center;">NOTE</p> <p>Transmission may not reach 160°F (71°C) oil temperature at idle for several minutes.</p> <p>8. TRANS TEMP gauge.</p> <p>9. FUEL gauge.</p>	<p>140°F (60°C) or more than 230°F (110°C) after engine has been properly warmed up (start engine (WP 0044) procedure completed).</p> <p>TRANS TEMP gauge indicates more than 250°F (121°C).</p> <p>FUEL gauge is inoperative, or indicates less than the required amount of fuel needed</p>

Table 1. PMCS - BEFORE - Continued

Item No.	Interval	Item to be Checked or Serviced	Procedure	Equipment Not Ready/ Available If:
18	Before	TRANSFER CASE Shift Lever and TRACTION CONTROL lever	<p style="text-align: center;">CAUTION</p> <p>Vehicle must be parked when making this check. Failure to comply may result in damage to equipment. Transfer case will be damaged if shifted while vehicle is moving.</p> <p style="text-align: center;">NOTE</p> <ul style="list-style-type: none"> • Engine must be running to perform this check. • Transmission must be in N (neutral) to perform this check. <p>1. TRANSFER CASE Shift Lever - Check operation: (WP 0048)</p>	to complete the mission.

Table 1. PMCS - BEFORE - Continued

Item No.	Interval	Item to be Checked or Serviced	Procedure	Equipment Not Ready/ Available If:
----------	----------	--------------------------------	-----------	------------------------------------

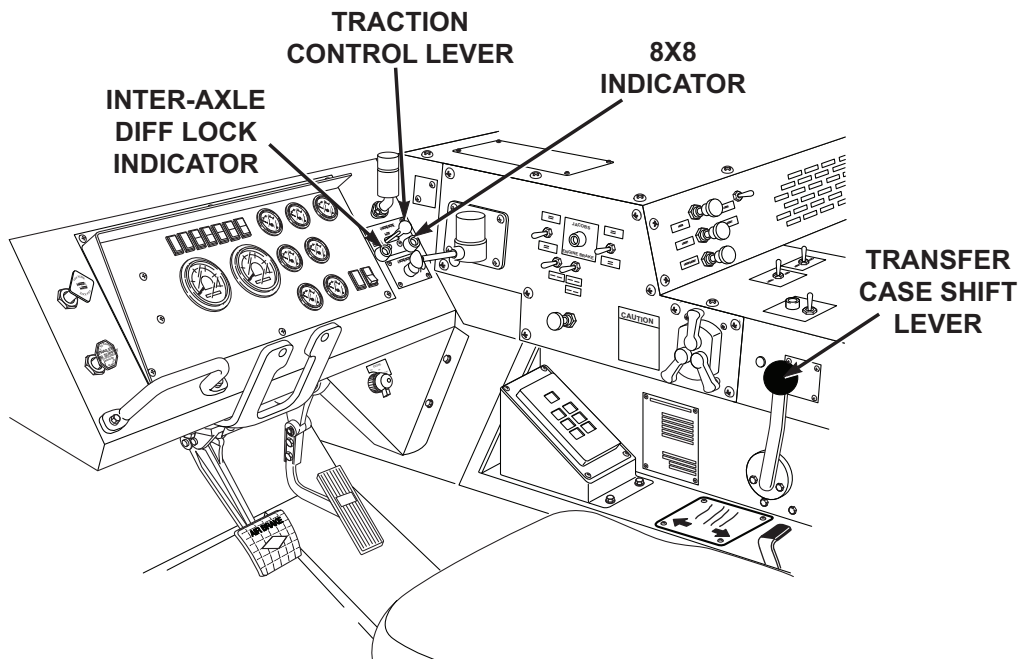

Figure 13.

		<ol style="list-style-type: none"> a. Set transfer case shift lever to each range position. b. Transfer case shift lever should move freely through all range positions. 	<p>TRANSFER CASE shift lever inoperable or binds between range detents.</p>
--	--	--	---

Table 1. PMCS - BEFORE - Continued

Item No.	Interval	Item to be Checked or Serviced	Procedure	Equipment Not Ready/ Available If:
19	Before	Engine Retarder/ Brake	<p>2. TRACTION CONTROL Lever - Check operation: (WP 0021)</p> <p>a. TRACTION CONTROL lever should slide smoothly, and interact with transfer case shift lever to show correct indications on dash panel.</p> <p style="text-align: center;">NOTE</p> <ul style="list-style-type: none"> • Engine must be running to perform this check. • Engine and transmission oil must be warm to perform this check. • Testing has shown that a reading of at least 180°F (64°C) on the WATER TEMP gauge is sufficient to perform this check. <p>1. Check engine retarder/brake for proper operation (WP 0049) (vehicle stationary) using the following procedures:</p> <p style="text-align: center;">NOTE</p> <p>Dashboard parking brake indicator will illuminate when PARKING BRAKE control is applied.</p> <p>a. Pull out PARKING BRAKE control.</p>	<p>TRACTION CONTROL lever or indicators inoperable.</p>

Table 1. PMCS - BEFORE - Continued

Item No.	Interval	Item to be Checked or Serviced	Procedure	Equipment Not Ready/ Available If:
----------	----------	--------------------------------	-----------	------------------------------------

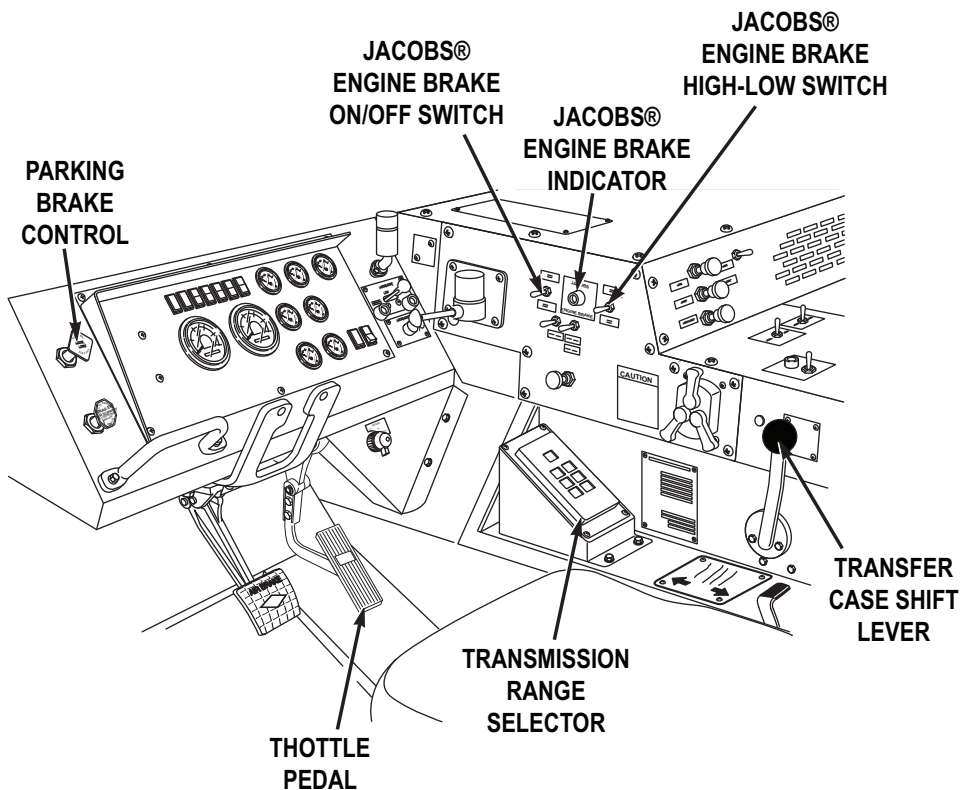

Figure 14.

		<ul style="list-style-type: none"> b. Set transfer case shift lever to N (NEUT) position. c. Set transmission range selector to D (drive) position. 	
--	--	---	--

Table 1. PMCS - BEFORE - Continued

Item No.	Interval	Item to be Checked or Serviced	Procedure	Equipment Not Ready/ Available If:
			<ul style="list-style-type: none"> d. Apply throttle pedal and increase engine speed to 1800-2100 rpm for several seconds to allow transmission to upshift to at least 2 (2nd gear range). e. Set JACOBS® ENGINE BRAKE HIGH/LOW switch (1) to HIGH. f. Set JACOBS ® ENGINE BRAKE ON/OFF switch to ON position, JACOBS ® ENGINE BRAKE indicator light will illuminate. g. Release throttle pedal and listen for engine "popping" or "chattering" sounds that indicate engine retarder/ brake is engaged and operating. h. Set JACOBS ® ENGINE BRAKE ON/OFF switch to OFF position, JACOBS ® ENGINE BRAKE indicator light will go out. i. Apply throttle pedal and increase engine speed to 1800-2100 rpm for several seconds to allow transmission to upshift to at least 2 (2nd gear range). 	

Table 1. PMCS - BEFORE - Continued

Item No.	Interval	Item to be Checked or Serviced	Procedure	Equipment Not Ready/ Available If:
20	Before	Steering	<p>j. Set JACOBS® ENGINE BRAKE HIGH/LOW switch (1) to LOW.</p> <p>k. Set JACOBS ® ENGINE BRAKE ON/OFF switch to ON position, JACOBS ® ENGINE BRAKE indicator light will illuminate.</p> <p>l. Release throttle pedal and listen for engine "popping" or "chattering" sounds that indicate engine retarder/ brake is engaged and operating.</p> <p>m. Set JACOBS ® ENGINE BRAKE ON/OFF switch to OFF position, JACOBS ® ENGINE BRAKE indicator light will go out.</p> <p style="text-align: center;">NOTE</p> <p>Engine must be running to perform this check.</p> <p>1. Check vehicle steering for proper operation:</p> <p>a. Turn steering wheel from full left to full right, back to full left.</p>	Steering inoperable or binds.

Table 1. PMCS - BEFORE - Continued

Item No.	Interval	Item to be Checked or Serviced	Procedure	Equipment Not Ready/ Available If:
21	Before	PTO Switch	<p style="text-align: center;">NOTE</p> <p>Engine must be running to perform this check.</p> <p>Set PTO ENGAGE switch to ON position. Indicator light will illuminate.</p>	PTO ENGAGE switch and/or indicator does not operate.

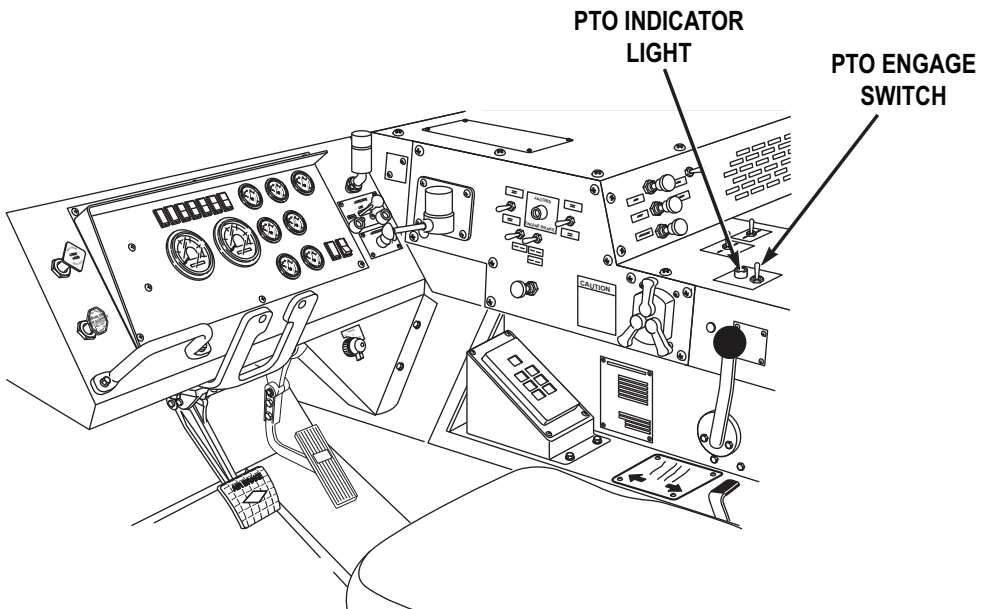

Figure 15.

Table 1. PMCS - BEFORE - Continued

Item No.	Interval	Item to be Checked or Serviced	Procedure	Equipment Not Ready/ Available If:
22	Before	Wiper/ Washer Control	<p style="text-align: center;">NOTE</p> <p>Operation of vehicle with mal-functioning windshield wiper may violate AR 385-55. (WP 0161)</p> <p>1. Check wiper function of wiper/washer control for proper operation. (WP 0035)</p>	

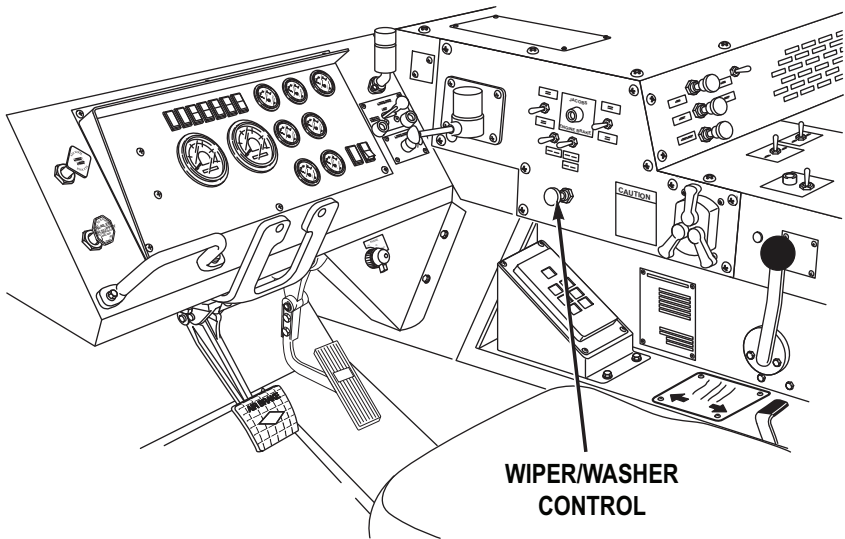

Figure 16.

		<p>2. Check washer function of wiper/washer control for proper operation. (WP 0035)</p>
--	--	---

Table 1. PMCS - BEFORE - Continued

Item No.	Interval	Item to be Checked or Serviced	Procedure	Equipment Not Ready/ Available If:
23	Before	Parking Brake Control	<p style="text-align: center;">NOTE</p> <ul style="list-style-type: none"> • Engine must be running to perform this check. • Operation of vehicle with malfunctioning windshield wiper may violate AR 385-55. (WP 0161) <p>1. Check PARKING BRAKE control for proper operation: (WP 0045)</p>	

Table 1. PMCS - BEFORE - Continued

Item No.	Interval	Item to be Checked or Serviced	Procedure	Equipment Not Ready/ Available If:

PARKING BRAKE CONTROL

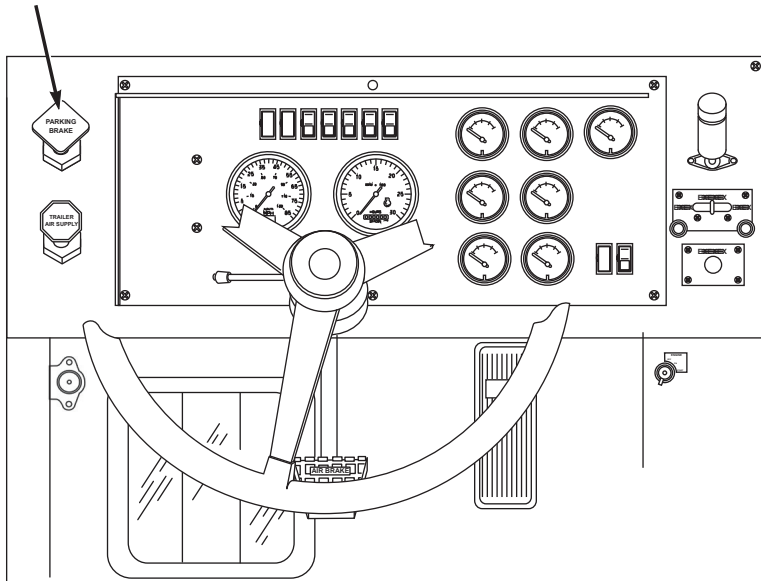

Figure 17.

- a. With vehicle at idle and service brake pedal engaged, (WP 0046) set transmission range selector to D (drive). (WP 0048)

NOTE

Dash-board parking brake indicator will illuminate when

Table 1. PMCS - BEFORE - Continued

Item No.	Interval	Item to be Checked or Serviced	Procedure	Equipment Not Ready/ Available If:
24	Before	Engine	<p>PARKING BRAKE control is applied.</p> <p>b. Pull out PARKING BRAKE control. (WP 0045)</p> <p>c. Release service brake pedal. (WP 0046)</p> <p>d. Set transmission range selector to N (neutral). (WP 0048)</p> <p>NOTE</p> <p>Operator may continue on with mission if vehicle requires no servicing.</p> <p>Shut OFF engine (WP 0057) (as required).</p>	<p>Vehicle moves with PARKING BRAKE control applied (pulled out).</p>

END OF WORK PACKAGE

**OPERATOR MAINTENANCE
DURING - PREVENTIVE MAINTENANCE**

INITIAL SETUP:

Tools and Special Tools

Gloves, Leather (WP 0163, Table 2)

Table 1. PMCS - DURING

Item No.	Interval	Item to be Checked or Serviced	Procedure	Equipment Not Ready/ Available If:
1	During	Engine	<p style="text-align: center;">WARNING</p> <div style="text-align: center;">  </div> <p>Ensure engine is OFF and eye protection is worn when checking for leaks. Failure to comply may result in injury or death to personnel.</p> <p>Check and/or listen for excessive smoke, unusual noise, rough running, and misfiring.</p> <p style="text-align: center;">NOTE</p> <p>Check trailer handbrake control lever only if a trailer is hooked up to vehicle.</p>	<p>Engine has excessive smoke, unusual noise, runs rough, or misfires.</p>

Table 1. PMCS - DURING - Continued

Item No.	Interval	Item to be Checked or Serviced	Procedure	Equipment Not Ready/ Available If:
2	During	Trailer Handbrake Control Lever	Check trailer handbrake control lever for proper operation. (WP 0047)	Control lever does not apply trailer brakes.

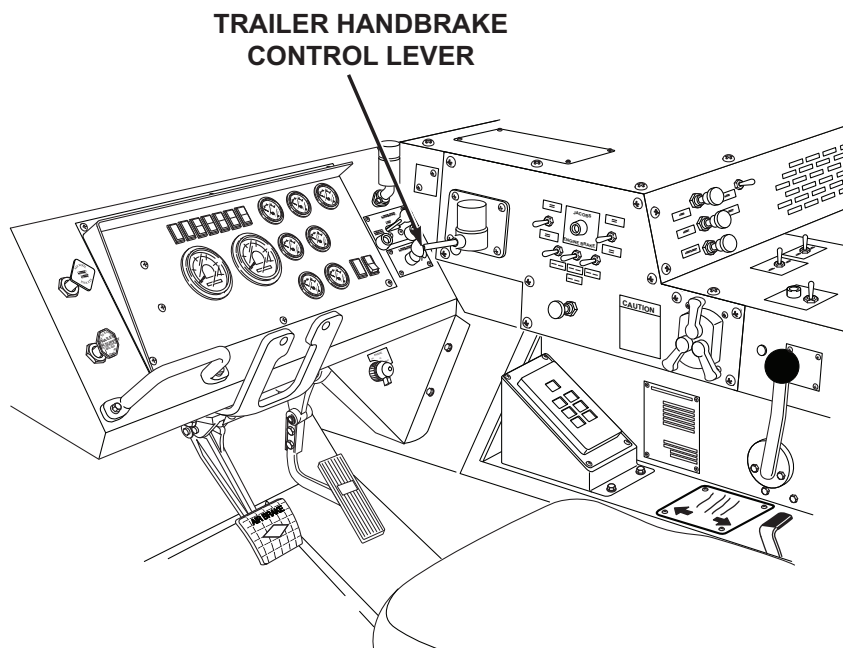

Figure 1.

Listen for actuation. If none, refer to applicable trailer operator's manual.

NOTE

During operation, all gauges should maintain the proper

Table 1. PMCS - DURING - Continued

Item No.	Interval	Item to be Checked or Serviced	Procedure	Equipment Not Ready/ Available If:
3	During	Instruments	<p>readings listed in the PMCS BEFORE checks. (WP 0145)</p> <p>Monitor all gauges, indicators, and warning lights for proper reading and operation while operating vehicle.</p>	Gauges, indicators, and warning lights do not read/operate properly.
4	During	Transmission	Check transmission for proper operation. (WP 0048)	Transmission slips or will not shift.
5	During	Steering	Be alert for any unusual noise, binding, or difficulty in steering during operation.	Steering binds or is unresponsive.
6	During	Service Brakes	Be alert for chatter, noise, and side pull.	Service brakes do not operate properly.

END OF WORK PACKAGE

**OPERATOR MAINTENANCE
AFTER - PREVENTIVE MAINTENANCE**

INITIAL SETUP:

Tools and Special Tools

Gloves, Leather (WP 0163, Table 2)

Table 1. PMCS - AFTER



Item No.	Interval	Item to be Checked or Serviced	Procedure	Equipment Not Ready/ Available If:
			<p style="text-align: center;">WARNING</p>  <p>Do not start engine or move vehicle when personnel are under vehicle or working on brake lines. Failure to comply may result in injury or death to personnel.</p> <p style="text-align: center;">WARNING</p>  <p>Ensure engine is OFF and eye protection is worn when checking for leaks. Failure to comply may result in injury or death to personnel.</p>	

Table 1. PMCS - AFTER - Continued

Item No.	Interval	Item to be Checked or Serviced	Procedure	Equipment Not Ready/ Available If:
			<p style="text-align: center;">NOTE</p> <p>Perform Operator's Before, After, and Weekly PMCS checks if:</p> <ul style="list-style-type: none"> • You are the assigned driver but have not operated the vehicle since the last weekly inspection. • You are operating the vehicle for the first time. <p style="text-align: center;">NOTE</p> <ul style="list-style-type: none"> • Clean all lubrication points with cleaning compound, solvent and allow to dry prior to servicing. • When using a grease gun, apply lubricant to the fitting until clean lubricant squeezes out of the part being lubricated. • Always refer to lubrication instructions (WP 0151) to ensure equipment has correct lubricants appropriate to operating environment (expected continuous temperatures). If not, remove/drain and reapply/refill equipment with appropriate lubricants for operating environment as 	

Table 1. PMCS - AFTER - Continued

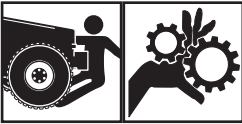
Item No.	Interval	Item to be Checked or Serviced	Procedure	Equipment Not Ready/ Available If:
1	After	Underneath Vehicle	<p>prescribed in lubrication instructions. (WP 0151)</p> <ol style="list-style-type: none"> 1. Check entire underside of vehicle for fluid and air leaks. 2. Check entire underside of vehicle for signs of fluid leakage (fuel, oil, and coolant). <p style="text-align: center;">WARNING</p> <div style="text-align: center;">  </div> <p>Prolonged contact with lubricating oil may cause skin rash. Immediately wash skin and clothing that come in contact with lubricating oil thoroughly and remove saturated clothing. Keep area well-ventilated to keep fumes at a minimum. Failure to comply may result in injury or death to personnel.</p> <p style="text-align: center;">CAUTION</p> <p>Do not fill hydraulic reservoir past FULL COLD mark. Fail-</p>	<p>Any fuel, Class III leak, or air lines/fittings leaking or damaged.</p> <p>Any fuel leak. Class III leak of any other fluid.</p>

Table 1. PMCS - AFTER - Continued

Item No.	Interval	Item to be Checked or Serviced	Procedure	Equipment Not Ready/ Available If:
2	After	Hydraulic Fluid Reservoir	<p>ure to comply may result in damage to equipment.</p> <p style="text-align: center;">NOTE</p> <ul style="list-style-type: none"> • Hydraulic oil expands when heated, which may give the operator false (high) fluid level readings if the vehicle has been recently operated. • If possible, wait until hydraulic reservoir is completely cooled down (minimum of 2 hours) prior to adding hydraulic oil, otherwise fill reservoir to FULL COLD mark. <p>1. Check that hydraulic fluid level in sight glass on hydraulic fluid reservoir is at FULL COLD mark (may be above FULL COLD mark if vehicle has been recently operated). If low, add hydraulic oil to FULL COLD mark:</p>	

Table 1. PMCS - AFTER - Continued

Item No.	Interval	Item to be Checked or Serviced	Procedure	Equipment Not Ready/ Available If:

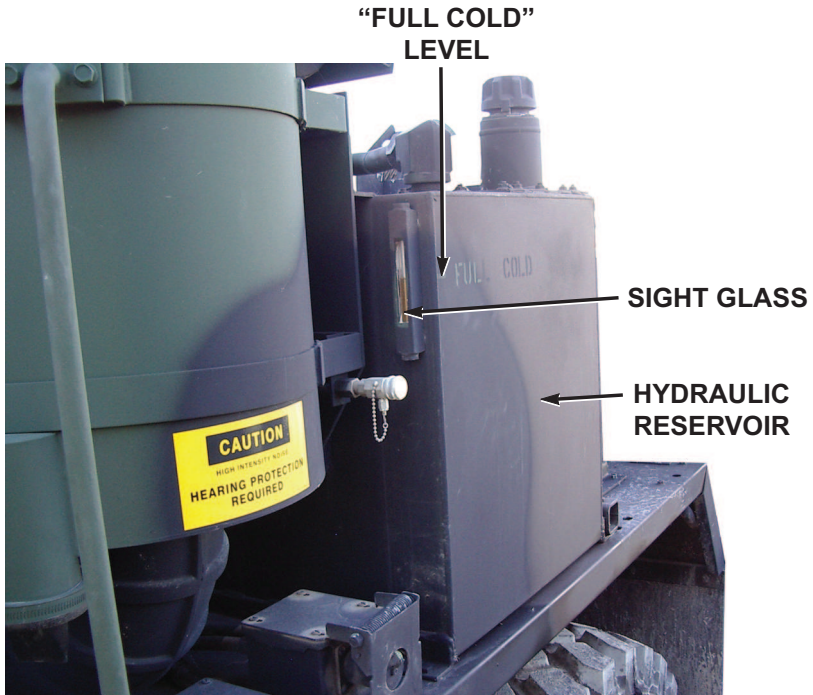

Figure 1.

- a. Remove cap from hydraulic reservoir.
- b. Fill hydraulic reservoir with lubricating oil (WP 0151, Table 4) until sight glass reads at FULL COLD mark.
- c. Install cap on hydraulic reservoir.

Table 1. PMCS - AFTER - Continued

Item No.	Interval	Item to be Checked or Serviced	Procedure	Equipment Not Ready/ Available If:
3	After	Driver Side Wheels	<ol style="list-style-type: none"> 2. Check appearance of hydraulic fluid in sight glass. Make sure it is clear and not milky or foamy. 1. Check wheels for broken, cracked, and bent surfaces. 2. Check lugnuts and wheel studs for obvious looseness and damage. If loose, tighten and report to maintenance as soon as practical. 	<p>Fluid appears milky or foamy.</p> <p>Wheel is broken, cracked, or bent.</p> <p>Two or more lugnuts or studs on the same wheel are missing, broken, or bent.</p>
4	After	Driver Side Shock Absorbers	Check driver side shock absorbers for leaks and damage.	Damaged or Class III leak present.
5	After	Crane Control Knobs	Check all crane control knobs to make sure information on knobs is legible.	Information on crane control knobs is not legible.
6	After	Rear Exterior	Check rear of vehicle for obvious damage that would impair operation.	Any damage that would impair operation.

Table 1. PMCS - AFTER - Continued

Item No.	Interval	Item to be Checked or Serviced	Procedure	Equipment Not Ready/ Available If:
7	After	Towing Gladhands	Check for presence and condition of towing gladhands and rubber grommets.	
8	After	Passenger side Wheels	<ol style="list-style-type: none"> 1. Check wheels for broken, cracked, and bent surfaces. 2. Check lugnuts and wheel studs for obvious looseness and damage. If loose, tighten and report to maintenance as soon as practical. 	<p>Wheel is broken, cracked, or bent.</p> <p>Two or more lugnuts or studs on the same wheel are missing, broken, or bent.</p>
9	After	Passenger Side Shock Absorbers	<p>Check passenger side shock absorbers for leaks and damage.</p> <p style="text-align: center;">WARNING</p> <div style="text-align: center;">  </div> <p>Vehicles air system is pressurized, be sure to wear proper eye protection and keep face away from drain valves while draining air reservoirs. Open air drain valves slowly to prevent sudden blast of air.</p>	

Table 1. PMCS - AFTER - Continued

Item No.	Interval	Item to be Checked or Serviced	Procedure	Equipment Not Ready/ Available If:
10	After	Air Reservoirs	<p>Failure to comply may result in injury to personnel.</p> <p style="text-align: center;">NOTE</p> <ul style="list-style-type: none"> • Only drain air reservoirs that are located under the passenger side battery box. • The M983A2 and M983A2 LET have three air reservoirs under the battery box, all other models have two. <p>1. Drain only air reservoirs under battery box as follows:</p>	

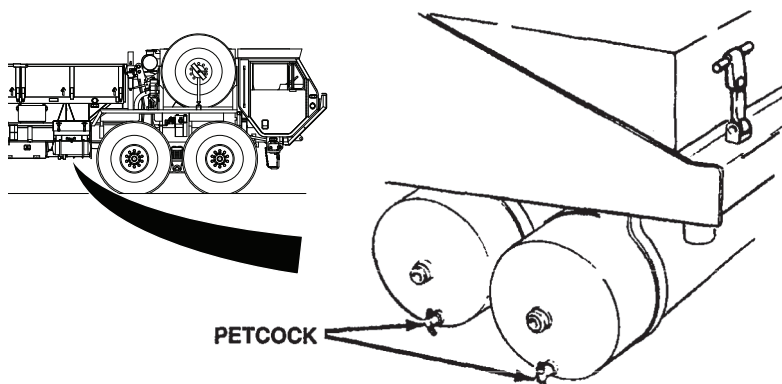

Figure 2.

Table 1. PMCS - AFTER - Continued

Item No.	Interval	Item to be Checked or Serviced	Procedure	Equipment Not Ready/ Available If:
11	After	Transmission	<p>a. Turn petcock on bottom of reservoir to open position.</p> <p>b. Let condensation drain off.</p> <p>c. Turn petcock on bottom of reservoir to closed position.</p> <p style="text-align: center;">CAUTION</p> <p>Clean around end of fill tube prior to removing dipstick. This will aid in preventing dirt or foreign matter from entering the transmission and causing damage.</p> <p style="text-align: center;">NOTE</p> <p>Vehicle is parked (WP 0056) on a flat, level surface.</p> <p>Engine is at idle.</p> <p>Transmission is at normal operating temperature, 160-200°F (71-93°C).</p> <p>1. With engine running, check transmission fluid level on dipstick:</p>	

Table 1. PMCS - AFTER - Continued

Item No.	Interval	Item to be Checked or Serviced	Procedure	Equipment Not Ready/ Available If:
----------	----------	--------------------------------	-----------	------------------------------------

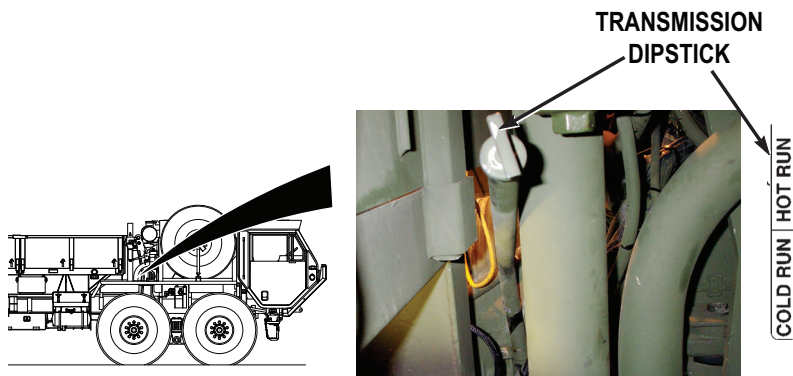

Figure 3.

NOTE

Fluid level should be between HOT FULL and HOT ADD marks.

2. Add OE/HDO (WP 0151, Table 2) as required.

Overfull. Notify field level maintenance.

12

After

Spare Tire/ Wheel

1. Check spare tire for cuts, gouges, cracks, or scratches. Remove any sharp objects.

Tire has cuts, gouges, or cracks that could result in tire failure. Tire is missing or

Table 1. PMCS - AFTER - Continued

Item No.	Interval	Item to be Checked or Serviced	Procedure	Equipment Not Ready/ Available If:
13	After	Exterior of Cab	<ol style="list-style-type: none"> 2. Check wheel for broken, cracked, and bent surfaces. 3. Check lugnuts and wheel studs for obvious looseness and damage. 1. Visually inspect cab and components for damage. <p style="text-align: center;">NOTE</p> <p>Operation of vehicle with broken/missing mirrors may violate AR 385-55. (WP 0161)</p>	<p>unserviceable.</p> <p>Wheel is broken, cracked, or bent.</p> <p>Two or more lugnuts or studs are missing, broken, or bent.</p> <p>Any component is damaged that would impair vehicle mission.</p>
14	After	Mirrors	Check condition of mirrors.	

Table 1. PMCS - AFTER - Continued

Item No.	Interval	Item to be Checked or Serviced	Procedure	Equipment Not Ready/ Available If:
----------	----------	--------------------------------	-----------	------------------------------------

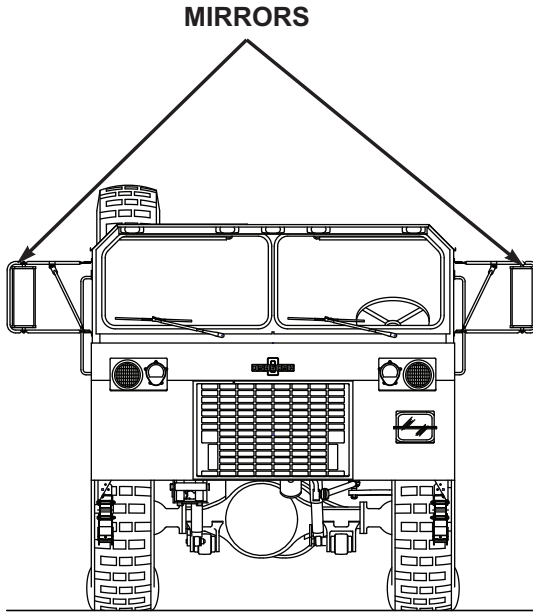

Figure 4.

NOTE

Operation of vehicle with damaged or missing windshield may violate AR 385-55. (WP 0161)

15

After

Windshield and Wiper Arms/Blades

1. Check windshield glass for presence and condition.

Table 1. PMCS - AFTER - Continued

Item No.	Interval	Item to be Checked or Serviced	Procedure	Equipment Not Ready/ Available If:
----------	----------	--------------------------------	-----------	------------------------------------

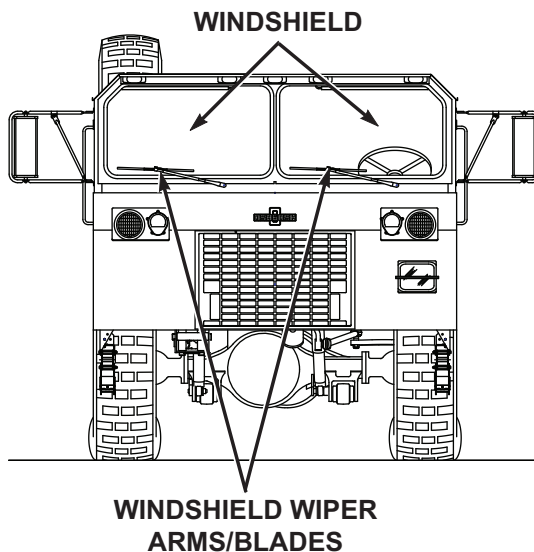

Figure 5.

16	After	Fan Switch	<p style="text-align: center;">NOTE</p> <p>Operation of vehicle with damaged wiper arms/blades may violate AR 385-55. (WP 0161)</p> <p>2. Check condition of wiper arms and blades.</p> <p>Check fan control switch for proper operation (WP 0036) in LO and HI positions.</p>	
----	-------	------------	---	--

Table 1. PMCS - AFTER - Continued

Item No.	Interval	Item to be Checked or Serviced	Procedure	Equipment Not Ready/ Available If:
----------	----------	--------------------------------	-----------	------------------------------------

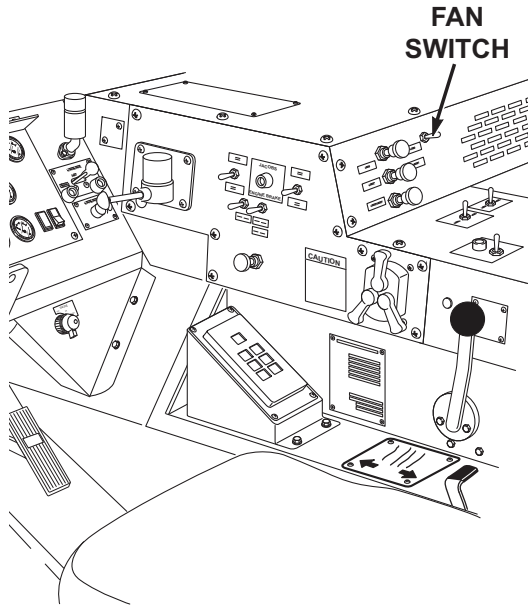

Figure 6.

NOTE

Operation of vehicle with malfunctioning windshield wiper may violate AR 385-55. (WP 0161)

17

After`

Wiper/
Washer
Control

1. Check wiper function of wiper/washer control for proper operation. (WP 0035)

Table 1. PMCS - AFTER - Continued

Item No.	Interval	Item to be Checked or Serviced	Procedure	Equipment Not Ready/ Available If:
----------	----------	--------------------------------	-----------	------------------------------------

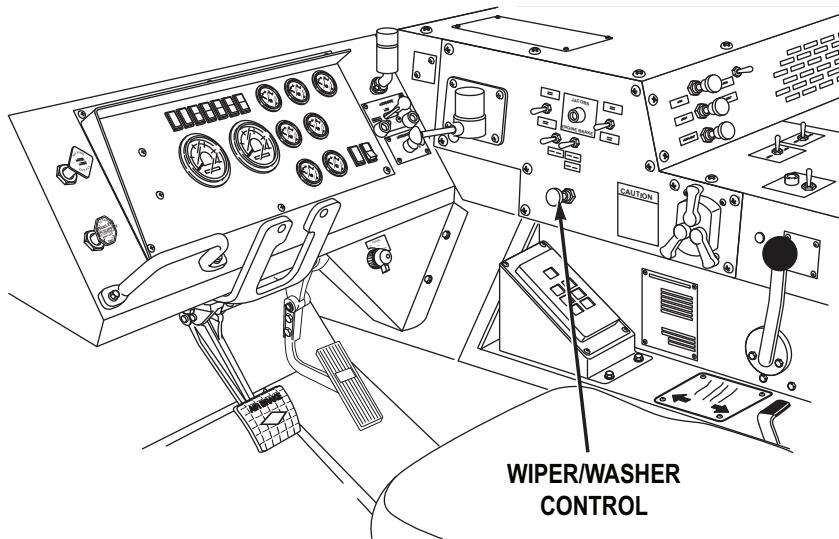

Figure 7.

18	After	Horns	<p>2. Check washer function of wiper/washer control for proper operation. (WP 0035)</p> <p style="text-align: center;">NOTE</p> <p>Operation of vehicle with malfunctioning horn may violate AR AR 385-55. (WP 0161)</p> <p>Check both horns (air and electric) for proper operation.</p>	
----	-------	-------	--	--

Table 1. PMCS - AFTER - Continued

Item No.	Interval	Item to be Checked or Serviced	Procedure	Equipment Not Ready/ Available If:
19	After	Turn Signal Control And Indicators	<p style="text-align: center;">NOTE</p> <ul style="list-style-type: none"> • Light checks will require assistance. • Operation of vehicle with malfunctioning turn signal control may violate AR 385-55. (WP 0161) <p>1. Check turn signal control for proper operation. (WP 0019)</p>	

Table 1. PMCS - AFTER - Continued

Item No.	Interval	Item to be Checked or Serviced	Procedure	Equipment Not Ready/ Available If:
----------	----------	--------------------------------	-----------	------------------------------------

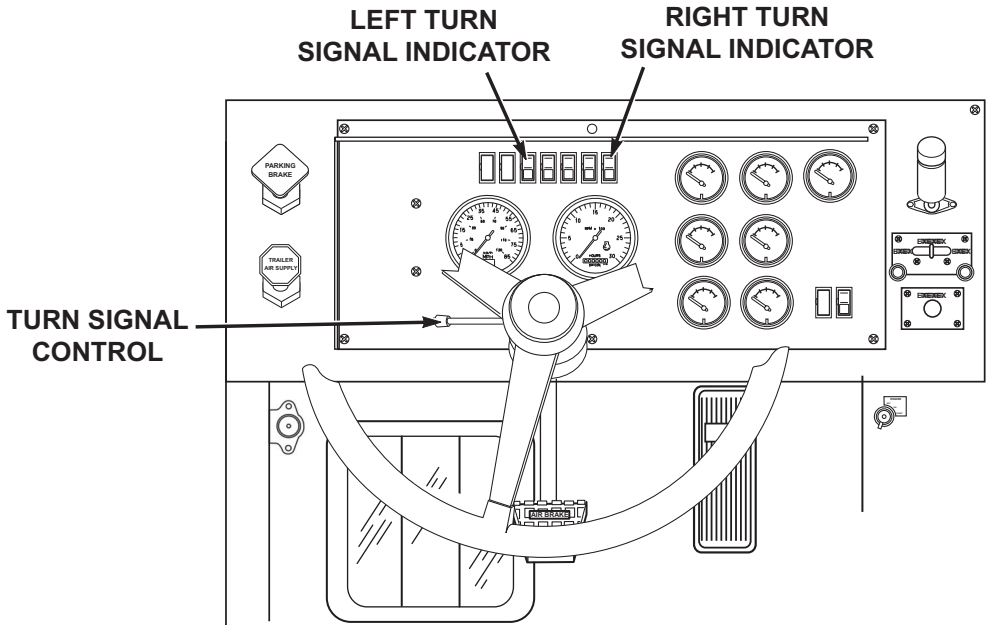

Figure 8.

2. Check turn signal indicators for proper operation. (WP 0021)

NOTE

- Light checks will require assistance.
- Operation of vehicle with malfunctioning emergency flasher

Table 1. PMCS - AFTER - Continued

Item No.	Interval	Item to be Checked or Serviced	Procedure	Equipment Not Ready/ Available If:
20	After	Emergency Flasher Control	<p>control may violate AR 385-55. (WP 0161)</p> <p>Check emergency flasher control for proper operation. (WP 0019)</p>	

**EMERGENCY
FLASHER CONTROL**

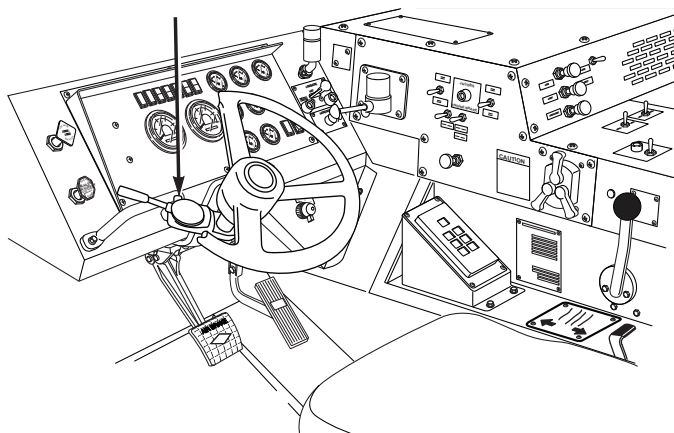

Figure 9.

NOTE

- Light checks will require assistance.
- Operation of vehicle with malfunctioning service lights may violate AR 385-55. (WP 0161)

Table 1. PMCS - AFTER - Continued

Item No.	Interval	Item to be Checked or Serviced	Procedure	Equipment Not Ready/ Available If:
21	After	Lights	<p>Check headlights, clearance lights, turn signals, and brake lights for proper operation.</p> <p style="text-align: center;">NOTE</p> <p>Operation of vehicle with malfunctioning beacon light may violate AR 385-55. (WP 0161)</p>	
22	After	Portable Beacon Light (If equipped)	<p>Remove beacon light from glove box and check for proper operation. (WP 0074)</p> <p style="text-align: center;">NOTE</p> <p>Complete this PMCS procedure only if material handling crane was used during mission.</p>	
23	After	Material Handling Crane (if used)	<p>1. Inspect crane for loose nuts and bolts, hydraulic leaks, damage to hydraulic hoses and lines, and obvious damage.</p> <p style="text-align: center;">NOTE</p> <p>For more information on material handling crane operating instructions, refer to grove crane operation (manual control) procedures. (WP 0042)</p>	Class III leak or damage to hoses, lines, or fittings.

Table 1. PMCS - AFTER - Continued

Item No.	Interval	Item to be Checked or Serviced	Procedure	Equipment Not Ready/ Available If:
			2. Check that crane hydraulic system is operable as follows: <ul style="list-style-type: none"> a. Start engine. (WP 0044) b. Set PTO ENGAGE switch to ON position. PTO indicator light will illuminate. 	

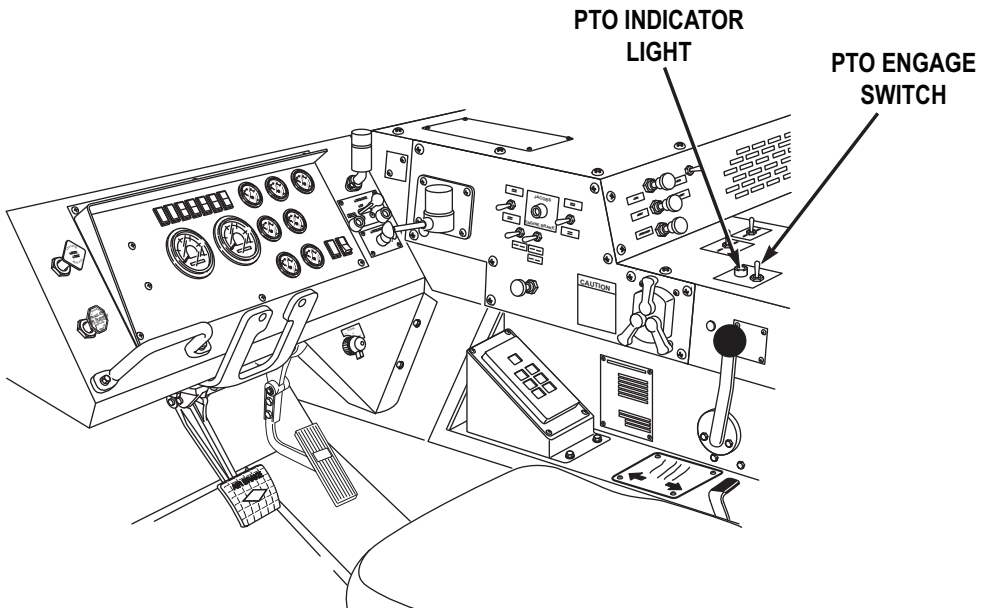

Figure 10.

		c. Set ON/OFF POWER switch to ON position.
--	--	--

Table 1. PMCS - AFTER - Continued

Item No.	Interval	Item to be Checked or Serviced	Procedure	Equipment Not Ready/ Available If:

ON/OFF POWER SWITCH

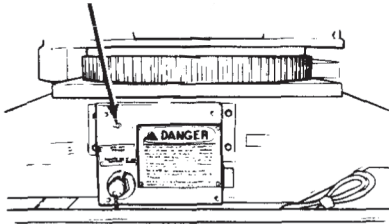

LATCH SWITCH

ENGINE HIGH IDLE SWITCH

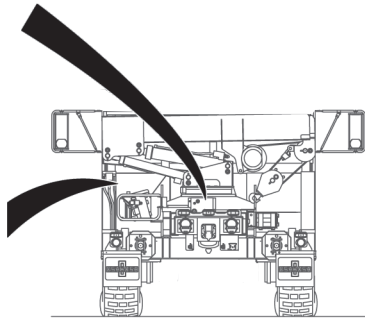
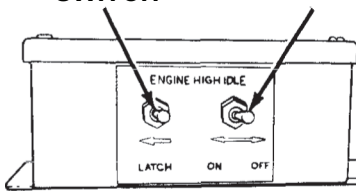

Figure 11.

- d. Set HIGH IDLE CONTROL switch to CONTINUOUS.

WARNING



Excessive noise levels are present any time the heavy-duty winch, crane, or retrieval system is operating. Wear

Table 1. PMCS - AFTER - Continued

Item No.	Interval	Item to be Checked or Serviced	Procedure	Equipment Not Ready/ Available If:
			<p>single hearing protection (earplugs or equivalent) while working around equipment when it is running. Failure to comply may result in injury or death to personnel. Seek medical aid should you suspect a hearing problem.</p> <p>e. Push and release LATCH switch. Engine speed should increase to approximately 1500 rpm.</p> <p>3. Check crane manual control levers as follows:</p> <p style="text-align: center;">WARNING</p> <div style="text-align: center;">  </div> <ul style="list-style-type: none"> • Stand clear of outrigger beams while operating levers. Failure to comply may result in injury or death to personnel. • Do not operate crane unless outriggers are firmly in place or vehicle could turn over. Failure to 	

Table 1. PMCS - AFTER - Continued

Item No.	Interval	Item to be Checked or Serviced	Procedure	Equipment Not Ready/ Available If:
			<p>comply may result in injury or death to personnel.</p> <ul style="list-style-type: none"> • Keep boom clear of all electrical lines and other obstacles while operating crane. Failure to comply may result in injury or death to personnel. <p style="text-align: center;">NOTE</p> <ul style="list-style-type: none"> • Operate control levers with light, even pressure. Moving lever slightly will cause slow movement of crane. Moving lever to full travel will cause faster movement of crane. • Outrigger beams will come out slower with light pressure on lever. Pushing lever to full travel will cause fast movement. <p>a. Move O/R EXT lever to IN position briefly.</p>	

Table 1. PMCS - AFTER - Continued

Item No.	Interval	Item to be Checked or Serviced	Procedure	Equipment Not Ready/ Available If:
----------	----------	--------------------------------	-----------	------------------------------------

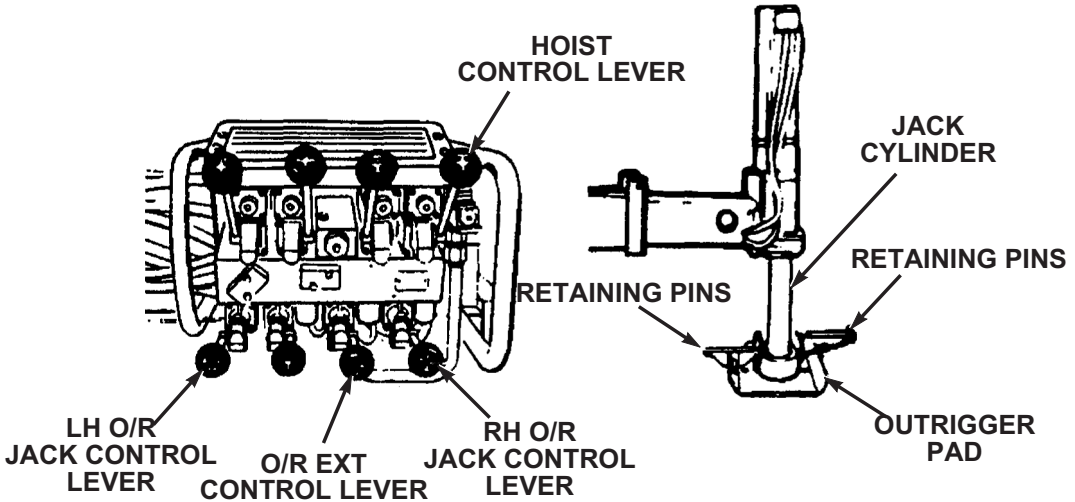

Figure 12.

		<p>b. Place both outrigger lockpins in unlock position.</p> <p>c. Check each control separately for malfunction, proper response, obvious damage, missing parts, binding, and extreme looseness.</p> <p>d. Move O/R EXT lever to OUT position until both outriggers is completely extended.</p> <p>e. Set up outrigger pads. Check that two retaining pins are</p>	<p>Controls malfunction, bind, or do not respond.</p> <p>Outrigger beam does not come out.</p> <p>Retaining pin missing</p>
--	--	--	---

Table 1. PMCS - AFTER - Continued

Item No.	Interval	Item to be Checked or Serviced	Procedure	Equipment Not Ready/ Available If:
			<p>attached to each outrigger pad.</p> <p style="text-align: center;">WARNING</p>  <p>Keep hands and feet clear of outrigger jack cylinders. Failure to comply may result in injury or death to personnel.</p> <p style="text-align: center;">NOTE</p> <p>Adjust outrigger pad position as required so rod end will lower into pad socket.</p> <p>f. Move LH O/R JACK control lever to DOWN position and lower outrigger jack until rod end is firmly seated in outrigger pad. Install retaining pins.</p> <p>g. Move RH O/R JACK control lever to DOWN position and lower outrigger jack until rod end is firmly seated in outrigger pad. Install retaining pins.</p>	<p>from either end.</p> <p>Outrigger jack cylinder will not come out or will not lower completely into pad.</p> <p>Outrigger jack cylinder will not come out or will not lower completely into pad.</p>

Table 1. PMCS - AFTER - Continued

Item No.	Interval	Item to be Checked or Serviced	Procedure	Equipment Not Ready/ Available If:
			<ul style="list-style-type: none"> h. Check that outrigger jack cylinder on each side of vehicle is out and down. i. Seat outriggers. j. Raise boom to operating position: 	<p>Crane hydraulic system does not operate.</p>

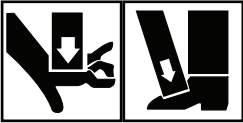
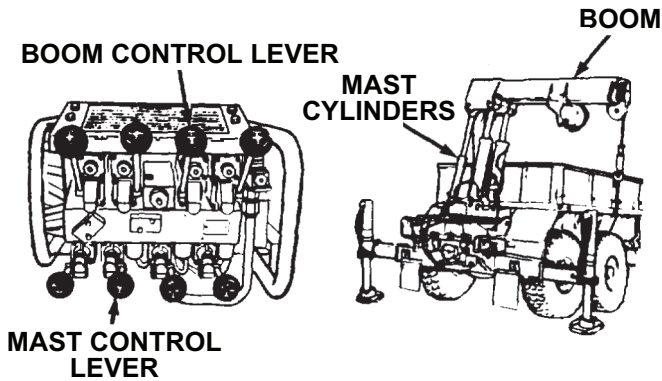

Figure 13.

		<p style="text-align: center;">WARNING</p> <div style="text-align: center;">  </div> <p>Do not operate crane unless outriggers are firmly in place or vehicle could turn over.</p>
--	--	--

Table 1. PMCS - AFTER - Continued

Item No.	Interval	Item to be Checked or Serviced	Procedure	Equipment Not Ready/ Available If:
			<p>Failure to comply may result in injury or death to personnel.</p> <p style="text-align: center;">CAUTION</p> <p>Do not let cable unwind and become slack, or cable may get tangled on drum.</p> <ol style="list-style-type: none"> (1) Move HOIST control lever to DOWN position until hook block rests on fender. (2) Pull and turn lockpin handle so handle end rests on bracket to unstow hook block. <p style="text-align: center;">CAUTION</p> <p>Do not allow load hook to contact taillight during inspection. Failure to comply may result in damage to equipment.</p> <p style="text-align: center;">NOTE</p> <p>Operation of vehicle with malfunctioning load hook may violate AR 385-55. (WP 0161)</p> <ol style="list-style-type: none"> (3) Check hook block and load hook for cracks, and proper operation. 	<p>Hook block or load hook is cracked.</p>

Table 1. PMCS - AFTER - Continued

Item No.	Interval	Item to be Checked or Serviced	Procedure	Equipment Not Ready/ Available If:
			<p style="text-align: center;">NOTE</p> <p>Operation of vehicle with malfunctioning load hook spring safety latch may violate AR 385-55. (WP 0161)</p> <p>(4) Check load hook spring safety latch for damage and proper operation.</p> <p>(5) Check hook block stowage guide wear plate for excessive wear.</p> <p style="text-align: center;">WARNING</p> <div style="text-align: center;">  </div> <p>When using crane on any vehicle, park vehicle clear of all overhead electrical lines. Keep boom clear of all electrical lines and other obstacles while operating crane. Failure to comply may result in injury or death to personnel.</p>	<p>Load hook spring safety latch doesn't open and/or close properly.</p>

Table 1. PMCS - AFTER - Continued

Item No.	Interval	Item to be Checked or Serviced	Procedure	Equipment Not Ready/ Available If:
			<p style="text-align: center;">CAUTION</p> <p>Do not hit outrigger leg with hook block. Failure to comply may result in damage to equipment.</p> <p>(6) Move BOOM control lever to UP position until hook is five to six feet (1.5 to 1.8 m) above driver side rear fender and boom is approximately 45° above horizontal.</p> <p>(7) Move MAST control lever to UP position until the mast is fully erect and the cylinders are fully extended. Use BOOM control lever UP simultaneously as required to maintain the boom at approximately 45° above horizontal until the mast is fully erect. Hold the MAST control lever to UP position for two to three seconds after mast is fully erect to ensure cylinders are fully filled with oil.</p> <p>k. Rotate and telescope boom:</p>	<p>Boom does not raise.</p> <p>Mast cylinder does not raise completely before stopping.</p>

Table 1. PMCS - AFTER - Continued

Item No.	Interval	Item to be Checked or Serviced	Procedure	Equipment Not Ready/ Available If:
			<p style="text-align: center;">WARNING</p>  <ul style="list-style-type: none"> • When using crane on any vehicle, park vehicle clear of all overhead electrical lines. Keep boom clear of all electrical lines and other obstacles while operating crane. Failure to comply may result in injury or death to personnel. • Ensure area is clear of personnel prior to moving SWING lever. Boom should be swung slowly enough so crane operator has complete control. Failure to comply may result in injury or death to personnel. <p style="text-align: center;">CAUTION</p> <p>Boom must be above vehicle sides for clearance.</p> <p>(1) Move swing control lever to CW position to move boom clockwise.</p>	<p>Boom does not turn clockwise.</p>

Table 1. PMCS - AFTER - Continued

Item No.	Interval	Item to be Checked or Serviced	Procedure	Equipment Not Ready/ Available If:

SWING CONTROL LEVER

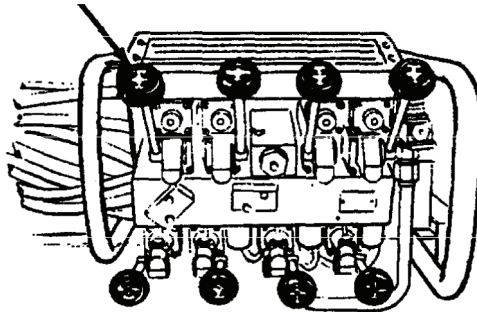

Figure 14.

- (2) Move swing control lever to CCW position to move boom counterclockwise.

Boom does not turn counterclockwise.

CAUTION

Keep hook block at least one ft. (30 cm) from end of boom. If hook block hits end of boom it may damage cable or hook block and crane will lose power. Wait six seconds for power to return and check crane for damage.

NOTE

- TELESCOPE and HOIST levers should be

Table 1. PMCS - AFTER - Continued

Item No.	Interval	Item to be Checked or Serviced	Procedure	Equipment Not Ready/ Available If:
			<p>operated at the same time.</p> <ul style="list-style-type: none"> Crane movement from one lever may be slower than the other when operating two levers together. <p>(3) Move TELESCOPE control lever to OUT position to extend boom while moving hoist control lever to DOWN position to pay out cable.</p>	<p>Extensions do not come out.</p>

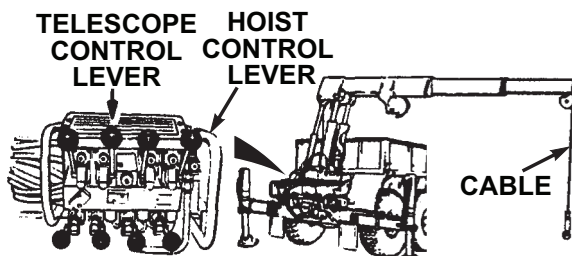

Figure 15.

		<p>(4) Check first, second, and third stages of boom for broken welds or obvious damage.</p>	<p>There are broken welds or obvious damage to boom.</p>
--	--	--	--

Table 1. PMCS - AFTER - Continued

Item No.	Interval	Item to be Checked or Serviced	Procedure	Equipment Not Ready/ Available If:
----------	----------	--------------------------------	-----------	------------------------------------

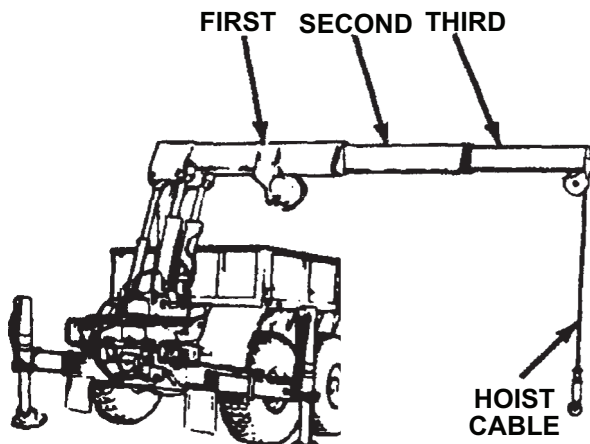

Figure 16.

WARNING



Always wear protective gloves when checking hoist cable. Never let cable run through hands. Frayed cables can cut severely. Failure to comply may result in injury or death to personnel.

- (5) Check cable on hoist for kinks, frays, or breaks.

Evidence of kinks, frays, or breaks.

Table 1. PMCS - AFTER - Continued

Item No.	Interval	Item to be Checked or Serviced	Procedure	Equipment Not Ready/ Available If:
			<p>(6) Check all hoses, fittings, valves, and cylinders for signs of leaks.</p> <p>(7) Check for cracked or broken welds.</p> <p>(8) Inspect turntable bearing bolts for obvious looseness.</p>	<p>Class III leak present.</p> <p>Cracked or broken welds are present.</p> <p>One or more turntable bearing bolts are loose.</p>

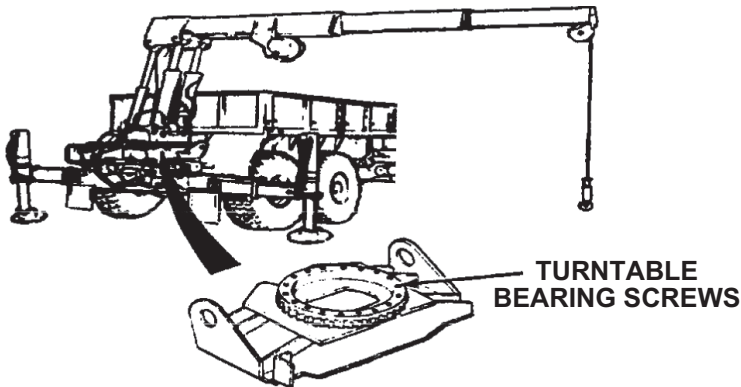

Figure 17.

CAUTION

Do not let cable become slack or cable may get tangled on drum.

Table 1. PMCS - AFTER - Continued

Item No.	Interval	Item to be Checked or Serviced	Procedure	Equipment Not Ready/ Available If:
			<p>(9) Move HOIST control lever in UP position to reel in cable.</p> <p>(10) Move HOIST control lever in DOWN position to pay out cable.</p> <p style="text-align: center;">NOTE</p> <p>For more information on material handling crane remote-control operating instructions, refer to grove crane operation (remote-control) procedures. (WP 0043)</p> <p>4. Check crane remote-control levers as follows:</p>	<p>Cable does not reel in.</p> <p>Cable does not pay out.</p>

Table 1. PMCS - AFTER - Continued

Item No.	Interval	Item to be Checked or Serviced	Procedure	Equipment Not Ready/ Available If:

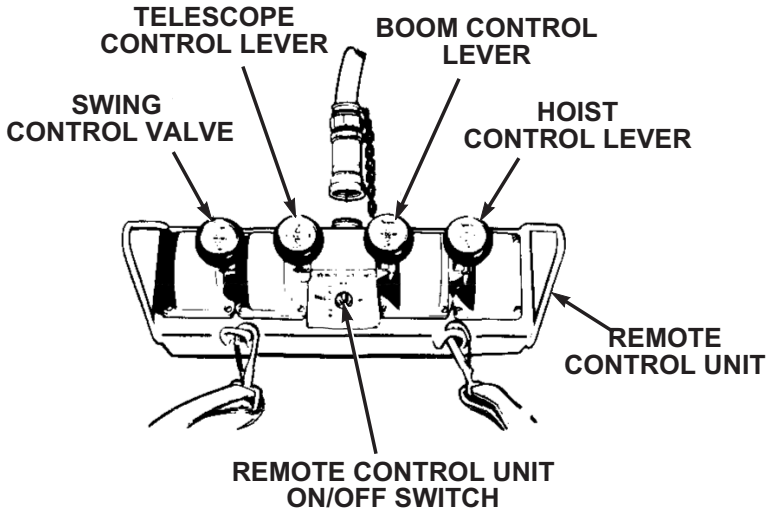

Figure 18.

- a. Set up REMOTE CONTROL UNIT passenger side. (WP 0043)

WARNING



- When using crane on any vehicle, park vehicle clear of all overhead electrical lines. Keep boom clear of all electrical lines and

Table 1. PMCS - AFTER - Continued

Item No.	Interval	Item to be Checked or Serviced	Procedure	Equipment Not Ready/ Available If:
			<p>other obstacles while operating crane. Failure to comply may result in injury or death to personnel.</p> <ul style="list-style-type: none"> • Ensure area is clear of personnel prior to moving SWING lever. Boom should be swung slowly enough so crane operator has complete control. Failure to comply may result in injury or death to personnel. <p style="text-align: center;">WARNING</p> <div style="text-align: center;">  </div> <p>If electrical power fails during crane operation, move switch on remote control unit to SHUTDOWN position. Failure to comply may result in injury or death to personnel.</p> <p style="text-align: center;">CAUTION</p> <p>Crane must be above vehicle sides for clearance.</p> <p style="text-align: center;">NOTE</p> <p>Operate control levers with light, even pressure. Moving lever slightly will cause slow</p>	

Table 1. PMCS - AFTER - Continued

Item No.	Interval	Item to be Checked or Serviced	Procedure	Equipment Not Ready/ Available If:
			<p>movement of crane. Moving lever to full travel will cause faster movement of crane.</p> <p>b. Check control levers for malfunction, proper response, obvious damage, missing parts, binding, and extreme looseness.</p> <p>c. Rotate and telescope boom:</p> <p style="text-align: center;">WARNING</p> <div style="text-align: center;">  </div> <p>Ensure area is clear of personnel prior to moving SWING lever. Boom should be swung slowly enough so crane operator has complete control. Failure to comply may result in injury or death to personnel.</p> <p>(1) Move SWING control lever to CW position to turn boom clockwise.</p>	<p>Controls malfunction, bind, or do not respond.</p> <p>Boom does not turn clockwise.</p>

Table 1. PMCS - AFTER - Continued

Item No.	Interval	Item to be Checked or Serviced	Procedure	Equipment Not Ready/ Available If:

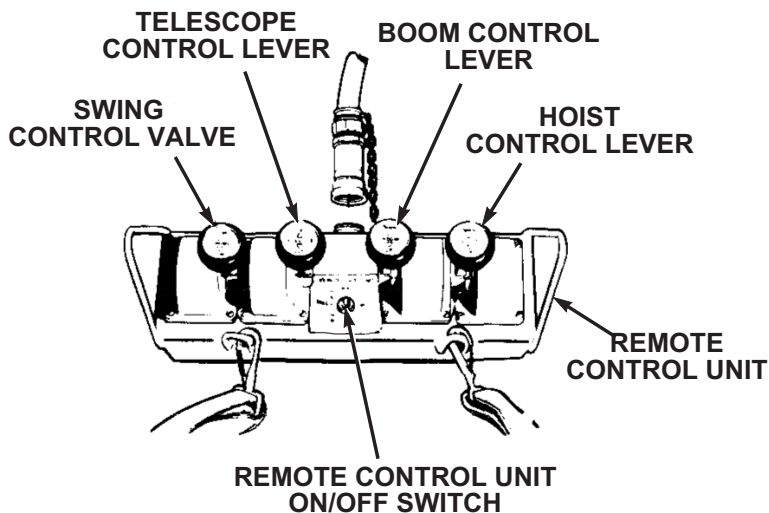

Figure 19.

- (2) Move SWING control lever to CCW position to turn boom counterclockwise.

Boom does not turn counterclockwise.

WARNING



When using crane on any vehicle, park vehicle clear of all overhead electrical lines. Keep boom clear of all elec-

Table 1. PMCS - AFTER - Continued

Item No.	Interval	Item to be Checked or Serviced	Procedure	Equipment Not Ready/ Available If:
			<p>trical lines and other obstacles while operating crane. Failure to comply may result in injury or death to personnel.</p> <p style="text-align: center;">CAUTION</p> <p>Do not let cable become slack or cable may get tangled on drum.</p> <p>(3) Move HOIST control lever to UP position to take up cable. Move BOOM control lever to UP position to raise boom.</p> <p>(4) Move HOIST control lever to DOWN position to pay out cable. Move BOOM control lever to DOWN position to lower boom to horizontal position.</p> <p style="text-align: center;">CAUTION</p> <ul style="list-style-type: none"> Keep hook block at least one ft. (30 cm) from end of boom. If hook block hits end of boom it may damage cable or hook block and crane will lose power. Wait six seconds for power and check crane for damage. 	<p>Cable does not reel in or boom does not raise.</p> <p>Cable does not pay out or boom does not lower.</p>

Table 1. PMCS - AFTER - Continued

Item No.	Interval	Item to be Checked or Serviced	Procedure	Equipment Not Ready/ Available If:
			<ul style="list-style-type: none"> • Do not let cable become slack or cable may get tangled on drum. <p style="text-align: center;">NOTE</p> <ul style="list-style-type: none"> • TELESCOPE and HOIST levers should be operated at the same time. • Crane movement from one lever may be slower than the other when operating two levers together. <p>(5) Move TELESCOPE control lever to OUT position while moving HOIST control lever to DOWN position to pay out cable.</p> <p>(6) Move HOIST control lever in UP position to reel in cable.</p> <p>(7) Check that crane and ENGINE HIGH IDLE do not operate when REMOTE CONTROL UNIT is in MHC-SHUTDOWN position. Notify organizational maintenance if crane and ENGINE HIGH IDLE</p>	<p>Extensions will not come out, or cable will not pay out.</p> <p>Cable will not reel in.</p> <p>Crane will operate and engine speed will increase to 1500 rpm.</p>

Table 1. PMCS - AFTER - Continued

Item No.	Interval	Item to be Checked or Serviced	Procedure	Equipment Not Ready/ Available If:
			<p>operates when in MHC-SHUTDOWN position.</p> <p>(8) Shut off remote-control switches.</p> <p>(9) Disconnect remote-control, passenger side.</p> <p>(10) Check operation of driver side remote-control station.</p> <p>(11) Connect remote-control to driver side remote-control station.</p> <p>(12) Check operation of crane remote-control levers.</p> <p>(13) Shut off remote-control switches.</p> <p>(14) Disconnect and stow REMOTE CONTROL UNIT.</p> <p>5. Shut down material handling crane.</p> <p>6. Check all hoses, fittings, valves, and cylinders for signs of leaks and damage.</p>	<p>Any Class III leak present.</p>

Table 1. PMCS - AFTER - Continued

Item No.	Interval	Item to be Checked or Serviced	Procedure	Equipment Not Ready/ Available If:
			7. Check for cracked or broken welds.	Cracked or broken welds.

END OF WORK PACKAGE

**OPERATOR MAINTENANCE
WEEKLY - PREVENTIVE MAINTENANCE**

INITIAL SETUP:

Tools and Special Tools

Gloves, Leather (WP 0163, Table 2)

Table 1. PMCS - WEEKLY



Item No.	Interval	Item to be Checked or Serviced	Procedure	Equipment Not Ready/ Available If:
			<p style="text-align: center;">WARNING</p>  <p>Do not start engine or move vehicle when personnel are under vehicle or working on brake lines. Failure to comply may result in injury or death to personnel.</p> <p style="text-align: center;">WARNING</p>  <p>Ensure engine is OFF and eye protection is worn when checking for leaks. Failure to comply may result in injury or death to personnel.</p>	

Table 1. PMCS - WEEKLY - Continued

Item No.	Interval	Item to be Checked or Serviced	Procedure	Equipment Not Ready/ Available If:
			<p style="text-align: center;">NOTE</p> <p>Perform Operator's Before, After, and Weekly PMCS checks if:</p> <ul style="list-style-type: none"> • You are the assigned driver but have not operated the vehicle since the last weekly inspection. • You are operating the vehicle for the first time. <p style="text-align: center;">NOTE</p> <ul style="list-style-type: none"> • Lubrication intervals are for normal operating conditions. Intervals may be shortened as required for severe operating conditions. • Clean all lubrication points with cleaning compound, solvent and allow to dry prior to servicing. • When using a grease gun, apply lubricant to the fitting until clean lubricant squeezes out of the part being lubricated. • Always refer to lubrication instructions (WP 0151) to ensure equipment has correct lubricants appropriate to operating environment (expected continuous 	

Table 1. PMCS - WEEKLY - Continued

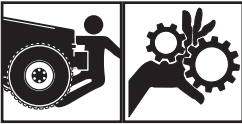
Item No.	Interval	Item to be Checked or Serviced	Procedure	Equipment Not Ready/ Available If:
			<p>temperatures). If not, remove/drain and reapply/refill equipment with appropriate lubricants for operating environment as prescribed in lubrication instructions. (WP 0151)</p> <p style="text-align: center;">WARNING</p> <div style="text-align: center;">  </div> <p>Do not operate a vehicle with a tire in an over-inflated or under-inflated condition, or with a questionable defect. Failure to comply may result in injury or death to personnel and damage to equipment.</p>	
1	Weekly	Driver Side Tires	Check tires for correct air pressure.	
2	Weekly	Propeller Shafts and U-Joints	<ol style="list-style-type: none"> 1. Check propeller shafts and U-joints for excessive movement, obvious damage, and loose, missing or broken nuts and screws. 	<p>Propeller shaft or U-Joint has excessive movement, obvious damage, or one or more nuts or screws are loose, miss-</p>

Table 1. PMCS - WEEKLY - Continued

Item No.	Interval	Item to be Checked or Serviced	Procedure	Equipment Not Ready/ Available If:
				ing, or damaged.

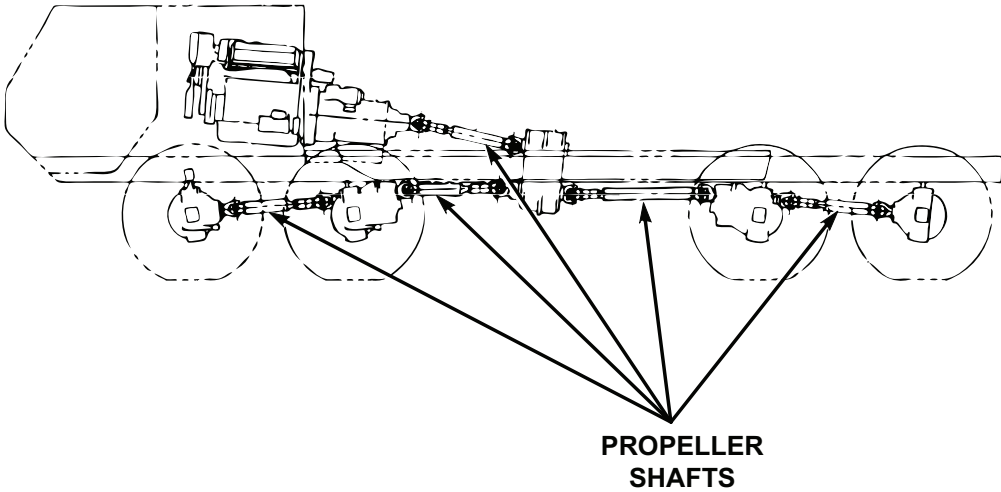

Figure 1.

NOTE

- When vehicle is operating under severe conditions, lubricate propeller shafts and universal joints every 50 hours of vehicle operation.
 - Complete Step 2 only if vehicle is operating under severe conditions.
2. Lubricate all propeller shafts, transmission to transfer case

Table 1. PMCS - WEEKLY - Continued

Item No.	Interval	Item to be Checked or Serviced	Procedure	Equipment Not Ready/ Available If:
3	Weekly	Axle Breathers	<p>propeller shaft, and U-joints with GAA (WP 0151) as required (refer to operator's semiannual PMCS table (item no. 2) for procedures. (WP 0149)</p> <p>Check four axle breathers for damage and free movement of vent caps on breather body.</p>	<p>Any axle breather caps are damaged or vent caps do not move freely on breather body.</p>

Table 1. PMCS - WEEKLY - Continued

Item No.	Interval	Item to be Checked or Serviced	Procedure	Equipment Not Ready/ Available If:
----------	----------	--------------------------------	-----------	------------------------------------

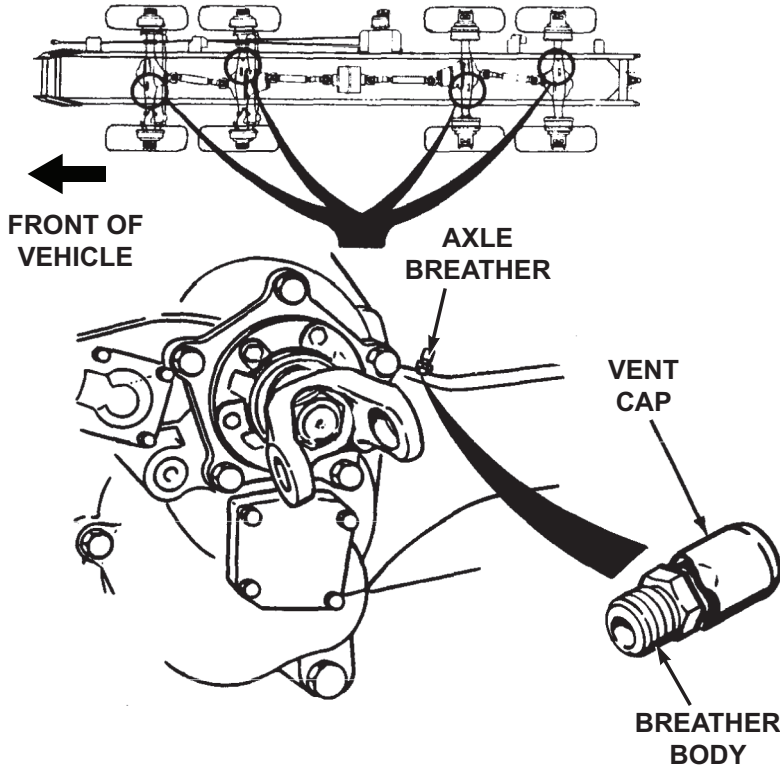

Figure 2.

4	Weekly	Drive Belts, Fan, and Pulleys	<ol style="list-style-type: none"> 1. Check drive belts for cracking, fraying, and breaks. Check for tightness. Play should be about 1/2 in. (13 mm). 	Any drive belt is broken, cracked to the belt fiber, has more than one crack
---	--------	-------------------------------	--	--

Table 1. PMCS - WEEKLY - Continued

Item No.	Interval	Item to be Checked or Serviced	Procedure	Equipment Not Ready/ Available If:
				(1/8 in. in depth or 50% of belt thickness), has frays more than 2 in. long or excessive play.

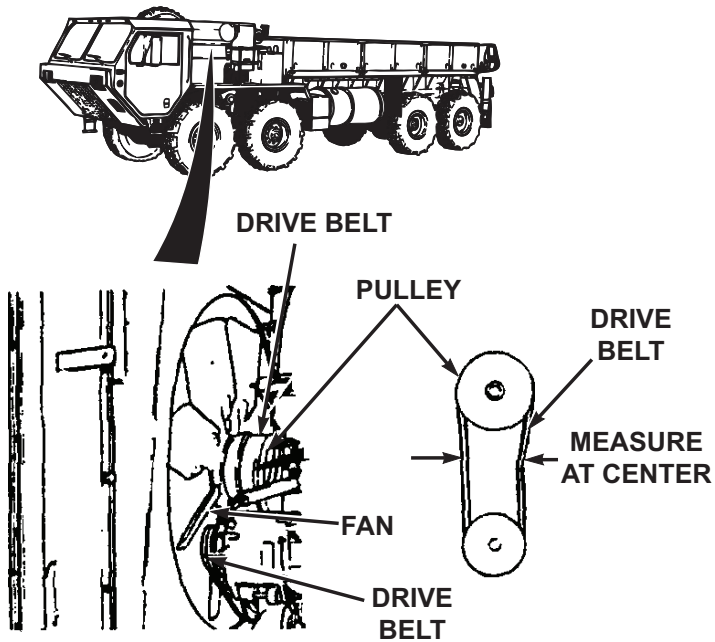

Figure 3.

Table 1. PMCS - WEEKLY - Continued

Item No.	Interval	Item to be Checked or Serviced	Procedure	Equipment Not Ready/ Available If:
5	Weekly	Exhaust System	<p>2. Check condition of fan for broken or cracked blades.</p> <p>3. Check for bent or damaged pulley.</p> <p style="text-align: center;">NOTE</p> <p>Operation of vehicle with any exhaust leaks may violate AR 385-55. (WP 0161)</p> <p>Check exhaust pipe, muffler, heatshield, tailpipe, raincap, clamps, and mounting for obvious damage, looseness, exhaust leak, and carbon buildup.</p>	<p>Fan damaged or un-serviceable.</p> <p>Pulley damaged or un-serviceable.</p> <p>Exhaust pipe between turbocharger and exhaust manifold leaks. Any exhaust pipe missing or damaged.</p>

Table 1. PMCS - WEEKLY - Continued

Item No.	Interval	Item to be Checked or Serviced	Procedure	Equipment Not Ready/ Available If:
----------	----------	--------------------------------	-----------	------------------------------------

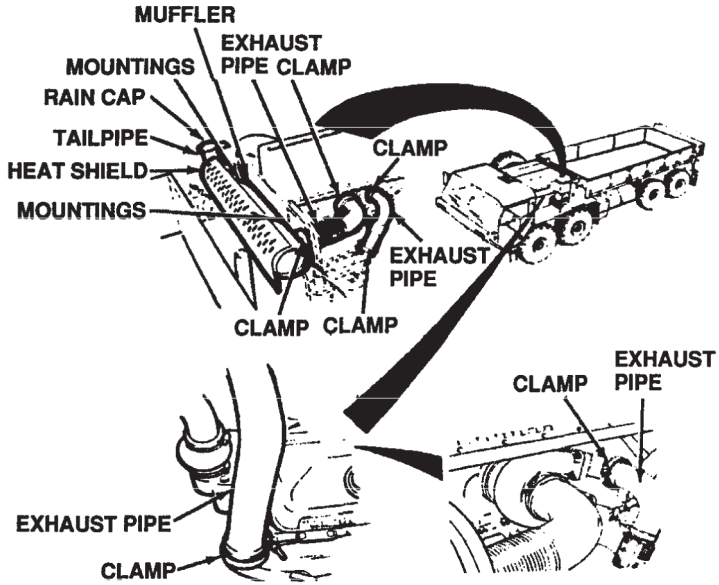

Figure 4.

6	Weekly	Air Intake System/ Ether Starting Aid	1. Squeeze air cleaner dust cap to remove excess dirt from canister.	
---	--------	--	--	--

Table 1. PMCS - WEEKLY - Continued

Item No.	Interval	Item to be Checked or Serviced	Procedure	Equipment Not Ready/ Available If:

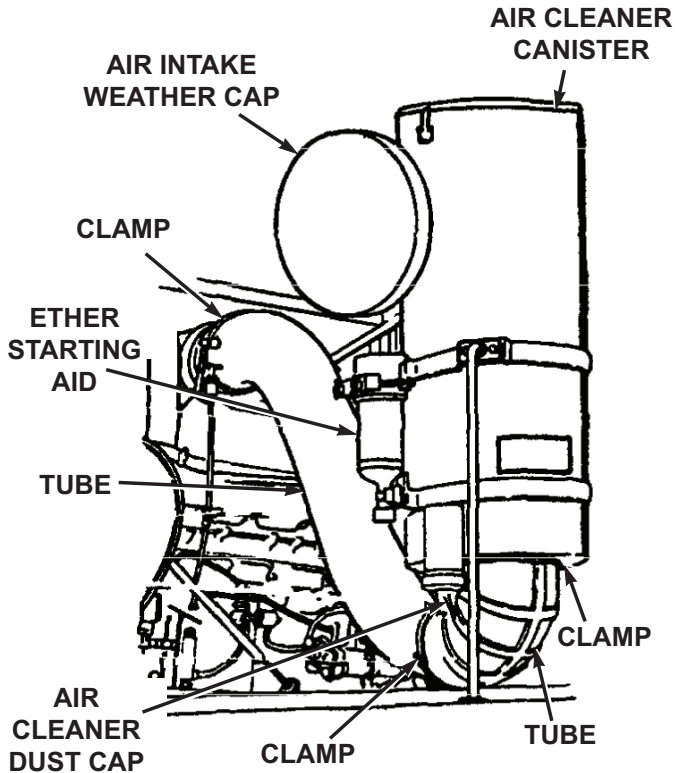

Figure 5.

2. Check that air intake weather cap is secure on air cleaner canister.

NOTE

Ether starting aid cartridges will be removed and solenoid

Table 1. PMCS - WEEKLY - Continued

Item No.	Interval	Item to be Checked or Serviced	Procedure	Equipment Not Ready/ Available If:
7	Weekly	Fuel Tank	<p>valve will be capped in tropical environment.</p> <p>3. Check ether starting aid for damage and missing hardware.</p> <p>4. Check air intake system for loose or damaged clamps and damage to tube.</p> <p>Check fuel tank, fuel hoses, fuel tank connections, and fuel tank socket head pipe plug for leaks and/or damage.</p>	<p>Air intake system has missing or inoperable clamps, or damage to tube.</p> <p>Any fuel leak.</p>

Table 1. PMCS - WEEKLY - Continued

Item No.	Interval	Item to be Checked or Serviced	Procedure	Equipment Not Ready/ Available If:

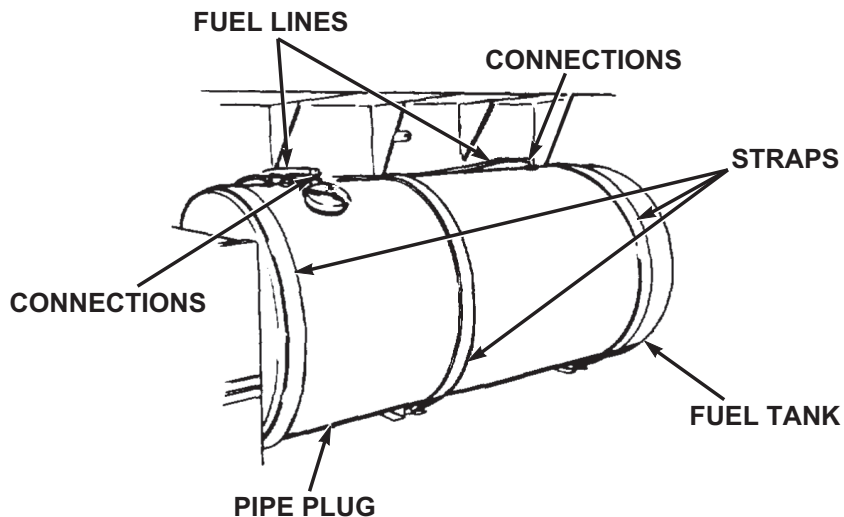

Figure 6.

8	Weekly	Fuel Tank Strainer	Check fuel tank strainer for clogs or damage. If strainer is clogged, clean strainer.	
---	--------	--------------------	---	--

Table 1. PMCS - WEEKLY - Continued

Item No.	Interval	Item to be Checked or Serviced	Procedure	Equipment Not Ready/ Available If:
----------	----------	--------------------------------	-----------	------------------------------------

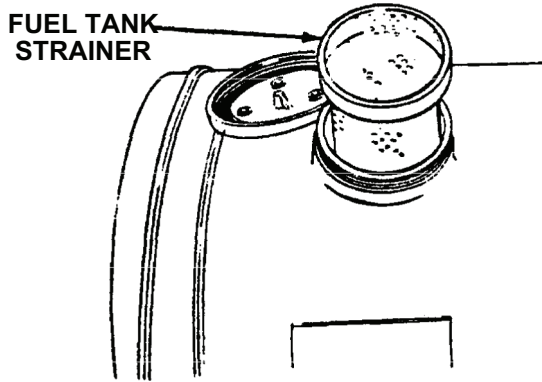

Figure 7.

9	Weekly	Hydraulic Pump	Check hydraulic pumps for loose screws, leaks, and damage. Check for loose hose fittings.	Class III leak present or any mounting screw is loose or missing.
---	--------	----------------	---	---

Table 1. PMCS - WEEKLY - Continued

Item No.	Interval	Item to be Checked or Serviced	Procedure	Equipment Not Ready/ Available If:
----------	----------	--------------------------------	-----------	------------------------------------

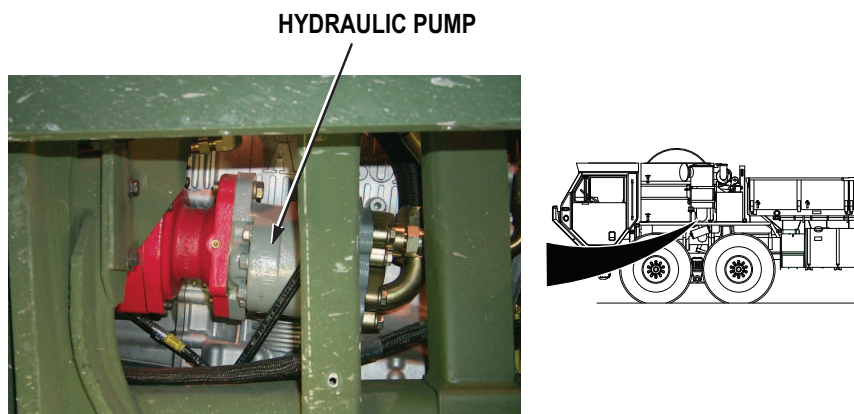

Figure 8.

10	Weekly	Hydraulic Hoses	<p>Check all hydraulic hose routing for obvious damage to hydraulic hoses, chaffing, and leaks.</p> <p style="text-align: center;">NOTE</p> <p>Operation of vehicle with bent, broken, or missing cargo body screws may violate AR 385-55.</p>	<p>Class III leak present. Chaffing or obvious damage to hydraulic hose present.</p>
----	--------	-----------------	---	--

Table 1. PMCS - WEEKLY - Continued

Item No.	Interval	Item to be Checked or Serviced	Procedure	Equipment Not Ready/ Available If:
11	Weekly	Cargo Bed Mounting Screws	Check that cargo bed mounting screws (both driver and passenger side) are not loose, broken, or missing.	One or more cargo bed mounting screws are broken or missing.

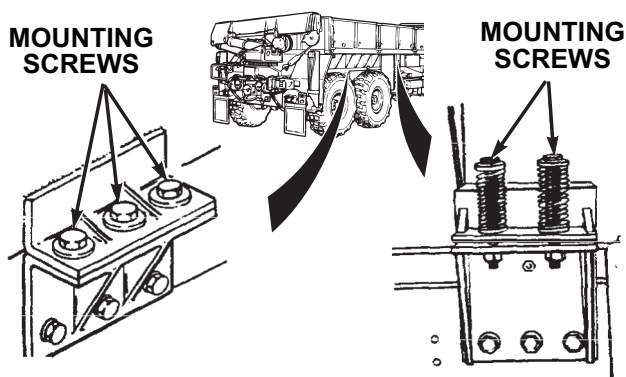

Figure 9.

12	Weekly	Storage Boxes	<ol style="list-style-type: none"> 1. Check all storage boxes/ compartments for missing hardware and other obvious damage. 2. Check inside all storage boxes/ compartments for torn or damaged seals, water in bottom of storage box/compartment, or other obvious damage. 	
13	Weekly	Rear Spring/ Parking	Check rear spring/parking brake chambers to ensure dust covers are in place and secure.	

Table 1. PMCS - WEEKLY - Continued

Item No.	Interval	Item to be Checked or Serviced	Procedure	Equipment Not Ready/ Available If:
14	Weekly	Brake Chambers		
		Towing Shackles	Check towing shackles for serviceability.	
15	Weekly	Pintle Hook	1. Check pintle hook for looseness and damaged locking mechanism of locking pin.	Pintle hook loose or locking mechanism damaged/ unserviceable.

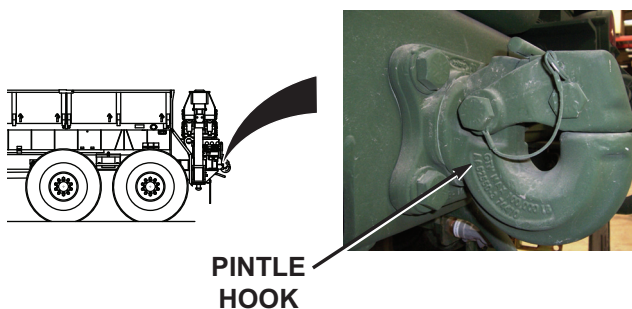
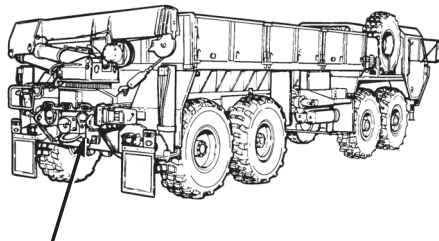

Figure 10.

16	Weekly	Rear Lifting Shackles	2. Clean pintle hook and coat with GAA. (WP 0151, Table 9) Check rear lifting shackles for serviceability.	
17	Weekly	Inter-vehicle	Check inter-vehicle connector seal and cable for damage.	

Table 1. PMCS - WEEKLY - Continued

Item No.	Interval	Item to be Checked or Serviced	Procedure	Equipment Not Ready/ Available If:
		Connector		



**INTER-VEHICLE
ELECTRICAL
CONNECTOR**

Figure 11.

WARNING



Do not operate a vehicle with a tire in an over-inflated or under-inflated condition, or with a questionable defect. Failure to comply may result in injury or death to personnel and damage to equipment.

NOTE

Inspection of passenger side tires includes spare tire.

Table 1. PMCS - WEEKLY - Continued

Item No.	Interval	Item to be Checked or Serviced	Procedure	Equipment Not Ready/ Available If:
18	Weekly	Passenger Side Tires	<p>Check tires for correct air pressure.</p> <p style="text-align: center;">NOTE</p> <p>Operation of vehicle with damaged/malfunctioning air compressor may violate AR 385-55. (WP 0161)</p>	
19	Weekly	Air Compressor	<p>Check air compressor for loose screws, damaged mounting flange and air hoses, and loose fittings/connections.</p>	<p>Screws missing, mounting flange broken, air hoses damaged or fittings/connections loose.</p>

Table 1. PMCS - WEEKLY - Continued

Item No.	Interval	Item to be Checked or Serviced	Procedure	Equipment Not Ready/ Available If:
----------	----------	--------------------------------	-----------	------------------------------------



Figure 12.

20	Weekly	Secondary Fuel Filter	Check secondary fuel filter for leaks or damage.	Any fuel leak.
----	--------	-----------------------	--	----------------

Table 1. PMCS - WEEKLY - Continued

Item No.	Interval	Item to be Checked or Serviced	Procedure	Equipment Not Ready/ Available If:
----------	----------	--------------------------------	-----------	------------------------------------

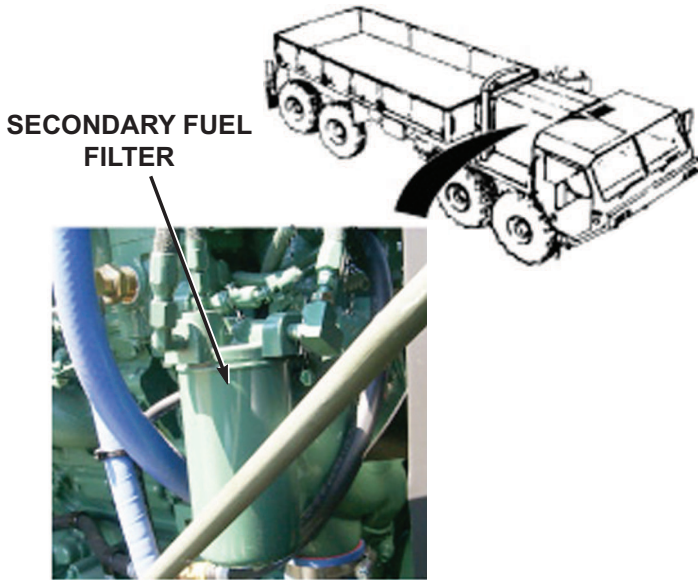

Figure 13.

21	Weekly	Turbocharger Oil Line	Check turbocharger oil line and fittings from rear of engine for signs of leaks and damage.	Any Class III leak present.
----	--------	-----------------------	---	-----------------------------

Table 1. PMCS - WEEKLY - Continued

Item No.	Interval	Item to be Checked or Serviced	Procedure	Equipment Not Ready/ Available If:
----------	----------	--------------------------------	-----------	------------------------------------

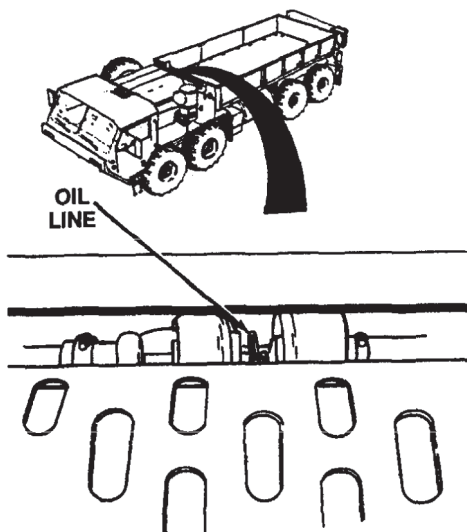

Figure 14.

WARNING



Wear proper eye and skin protection when working around batteries. Do not smoke, have open flames, or

Table 1. PMCS - WEEKLY - Continued

Item No.	Interval	Item to be Checked or Serviced	Procedure	Equipment Not Ready/ Available If:
22	Weekly	Batteries	<p>make sparks around batteries, especially if caps are off. Batteries can explode. Failure to comply may result in injury or death to personnel.</p> <p style="text-align: center;">WARNING</p> <div data-bbox="543 687 788 808" style="text-align: center;"> </div> <p>Remove all jewelry such as rings, ID tags, bracelets, etc. prior to working on or around vehicle. Jewelry and tools can catch on equipment, contact positive electrical circuits, and cause a direct short, severe burns, or electrical shock. Failure to comply may result in injury or death to personnel.</p> <p>1. Check battery box for damage.</p>	Cracks or holes in battery box.

Table 1. PMCS - WEEKLY - Continued

Item No.	Interval	Item to be Checked or Serviced	Procedure	Equipment Not Ready/ Available If:
----------	----------	--------------------------------	-----------	------------------------------------

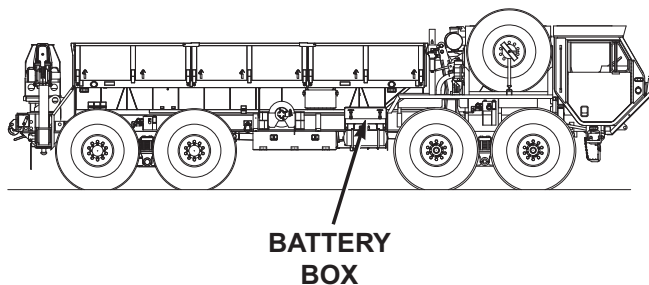

Figure 15.

23	Weekly	Spare Tire Davit And Carrier	<ol style="list-style-type: none"> 2. Check battery cables for presence, frays, splits, and looseness. 3. Check for loose, missing, or damaged batteries and corroded or burnt battery terminals. <p>Check spare tire davit and carrier for damage, missing parts.</p>	<p>Battery cables missing, frayed, split, or loose.</p> <p>One or more batteries missing, cracked, or unserviceable. Any battery terminal corroded or burnt. Any hold down not secure.</p>
----	--------	------------------------------	--	--

Table 1. PMCS - WEEKLY - Continued

Item No.	Interval	Item to be Checked or Serviced	Procedure	Equipment Not Ready/ Available If:
----------	----------	--------------------------------	-----------	------------------------------------

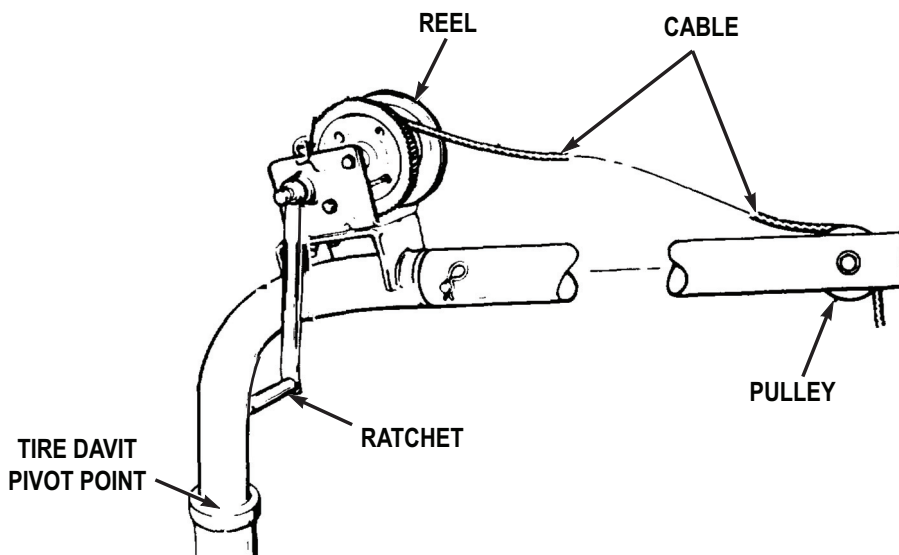

Figure 16.

24	Weekly	Spare Tire Retainer	Check spare tire retainer correctly seated and locking handle tight.	
----	--------	---------------------	--	--

Table 1. PMCS - WEEKLY - Continued

Item No.	Interval	Item to be Checked or Serviced	Procedure	Equipment Not Ready/ Available If:
----------	----------	--------------------------------	-----------	------------------------------------

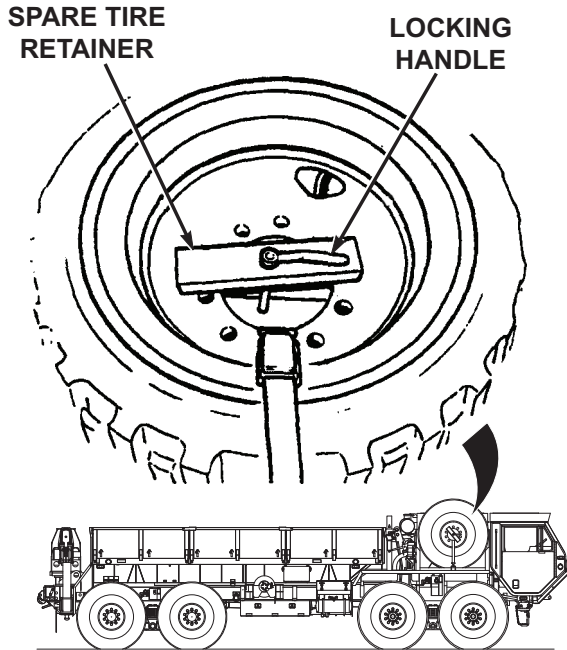

Figure 17.

25	Weekly	Air Dryer	Check air dryer for loose screws and connections.	
----	--------	-----------	---	--

Table 1. PMCS - WEEKLY - Continued

Item No.	Interval	Item to be Checked or Serviced	Procedure	Equipment Not Ready/ Available If:
----------	----------	--------------------------------	-----------	------------------------------------

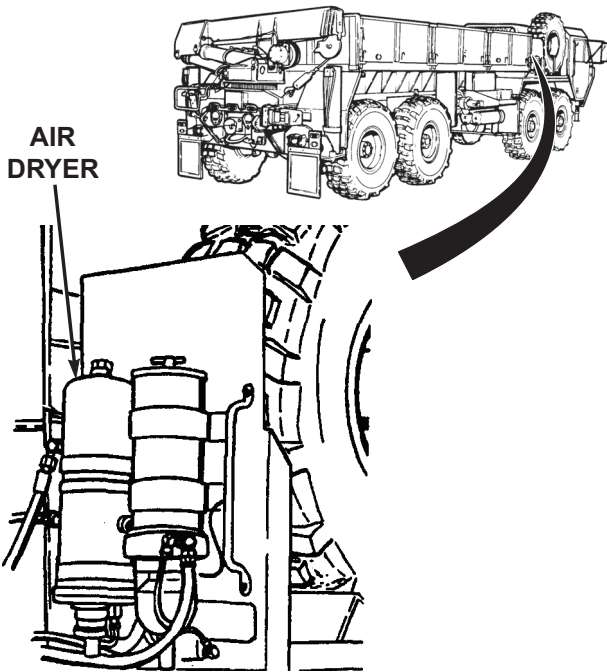

Figure 18.

NOTE

Pressurize air system prior to performing this check.

26	Weekly	Air Lines and Hoses	Check routing, for obvious damage to air lines and hoses. Check for leaks.	Any leaks or damage to air lines, hoses, or fit-
----	--------	---------------------	--	--

Table 1. PMCS - WEEKLY - Continued

Item No.	Interval	Item to be Checked or Serviced	Procedure	Equipment Not Ready/ Available If:
27	Weekly	Doors, Handles, and Windows	<p style="text-align: center;">NOTE</p> <p>Operation of vehicle with damaged doors or windows may violate AR 385-55. (WP 0161)</p> <p>Check condition and operation of door, handles, and windows. (WP 0018)</p>	things are found.
28	Weekly	Cab Temperature Controls	<p style="text-align: center;">NOTE</p> <p>Start Engine. (WP 0044) Engine must be running for remaining PMCS checks.</p> <p>1. Check cab temperature controls for proper for proper operation: (WP 0036)</p>	

Table 1. PMCS - WEEKLY - Continued

Item No.	Interval	Item to be Checked or Serviced	Procedure	Equipment Not Ready/ Available If:

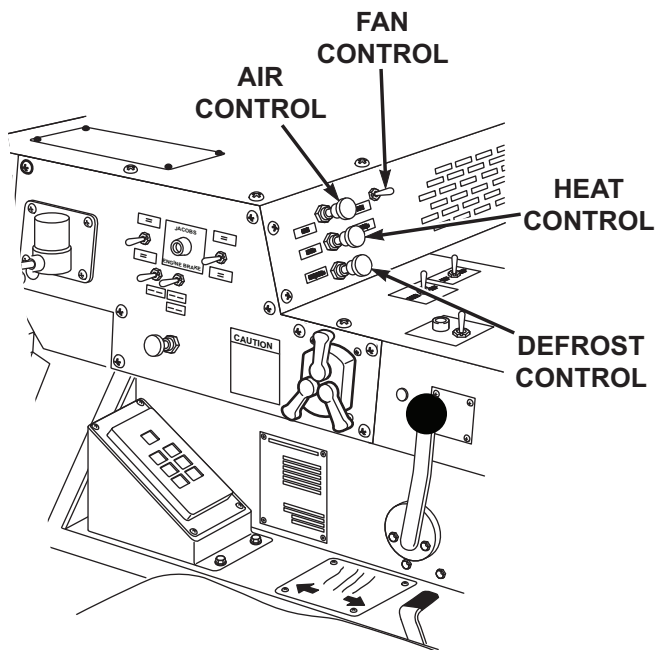

Figure 19.

- a. Check AIR control.
- b. Check HEAT control.
- c. Check DEFROST control.
- d. Check FAN control.

Table 1. PMCS - WEEKLY - Continued

Item No.	Interval	Item to be Checked or Serviced	Procedure	Equipment Not Ready/ Available If:
29	Weekly	Material Handling Crane	<ol style="list-style-type: none"> 1. Inspect crane for loose nuts and bolts, hydraulic leaks, damage to hydraulic hoses and lines, and obvious damage. <p style="text-align: center;">NOTE</p> <p>For more information on material handling crane operating instructions, refer to grove crane operation (manual control) procedures. (WP 0042)</p> <ol style="list-style-type: none"> 2. Check that crane hydraulic system is operable as follows: <ol style="list-style-type: none"> a. Start engine. (WP 0044) b. Set PTO ENGAGE switch to ON position. PTO indicator light will illuminate. 	Class III leak present or damage to hoses, lines, or fittings.

Table 1. PMCS - WEEKLY - Continued

Item No.	Interval	Item to be Checked or Serviced	Procedure	Equipment Not Ready/ Available If:

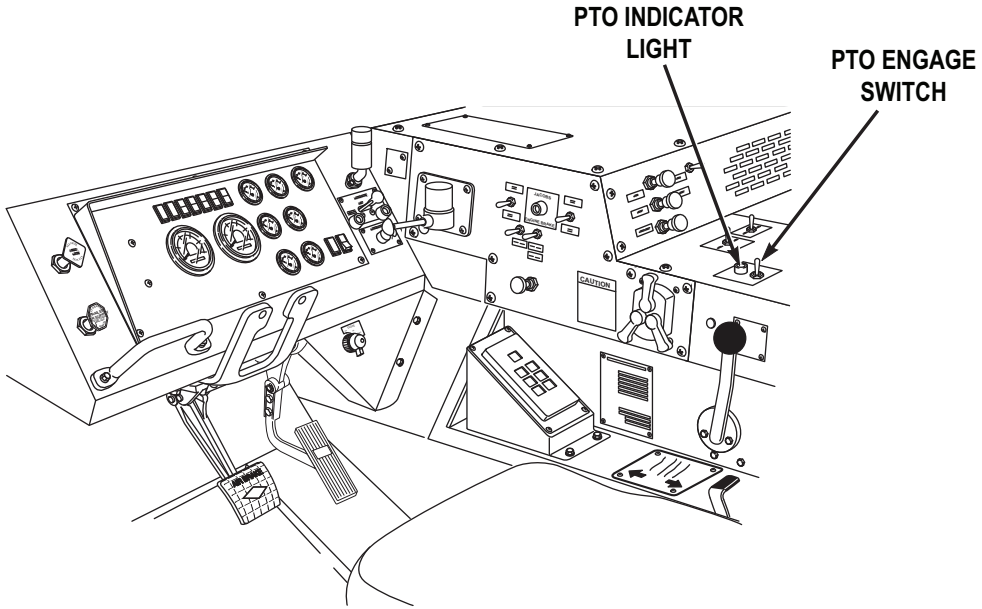

Figure 20.

- c. Set ON/OFF POWER switch to ON position.

Table 1. PMCS - WEEKLY - Continued

Item No.	Interval	Item to be Checked or Serviced	Procedure	Equipment Not Ready/ Available If:

ON/OFF POWER SWITCH

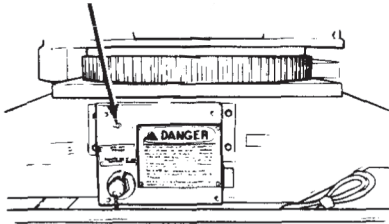

LATCH SWITCH

ENGINE HIGH IDLE SWITCH

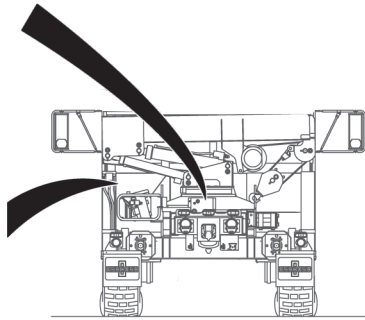
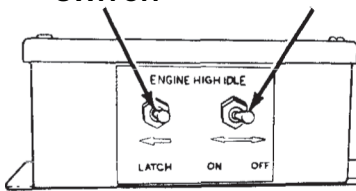

Figure 21.

- d. Set HIGH IDLE CONTROL switch to CONTINUOUS.

WARNING



Excessive noise levels are present any time the heavy-duty winch, crane, or retrieval system is operating. Wear

Table 1. PMCS - WEEKLY - Continued

Item No.	Interval	Item to be Checked or Serviced	Procedure	Equipment Not Ready/ Available If:
			<p>single hearing protection (earplugs or equivalent) while working around equipment when it is running. Failure to comply may result in injury or death to personnel. Seek medical aid should you suspect a hearing problem.</p> <p>e. Push and release LATCH switch. Engine speed should increase to approximately 1500 rpm.</p> <p>3. Check crane manual control levers as follows:</p> <p style="text-align: center;">WARNING</p> <div style="text-align: center;">  </div> <ul style="list-style-type: none"> • Stand clear of outrigger beams while operating levers. Failure to comply may result in injury or death to personnel. • Do not operate crane unless outriggers are firmly in place or vehicle could turn over. Failure to 	

Table 1. PMCS - WEEKLY - Continued

Item No.	Interval	Item to be Checked or Serviced	Procedure	Equipment Not Ready/ Available If:
			<p>comply may result in injury or death to personnel.</p> <ul style="list-style-type: none"> • Keep boom clear of all electrical lines and other obstacles while operating crane. Failure to comply may result in injury or death to personnel. <p style="text-align: center;">NOTE</p> <ul style="list-style-type: none"> • Operate control levers with light, even pressure. Moving lever slightly will cause slow movement of crane. Moving lever to full travel will cause faster movement of crane. • Outrigger beams will come out slower with light pressure on lever. Pushing lever to full travel will cause fast movement. <p>a. Move O/R EXT lever to IN position briefly.</p>	

Table 1. PMCS - WEEKLY - Continued

Item No.	Interval	Item to be Checked or Serviced	Procedure	Equipment Not Ready/ Available If:
----------	----------	--------------------------------	-----------	------------------------------------

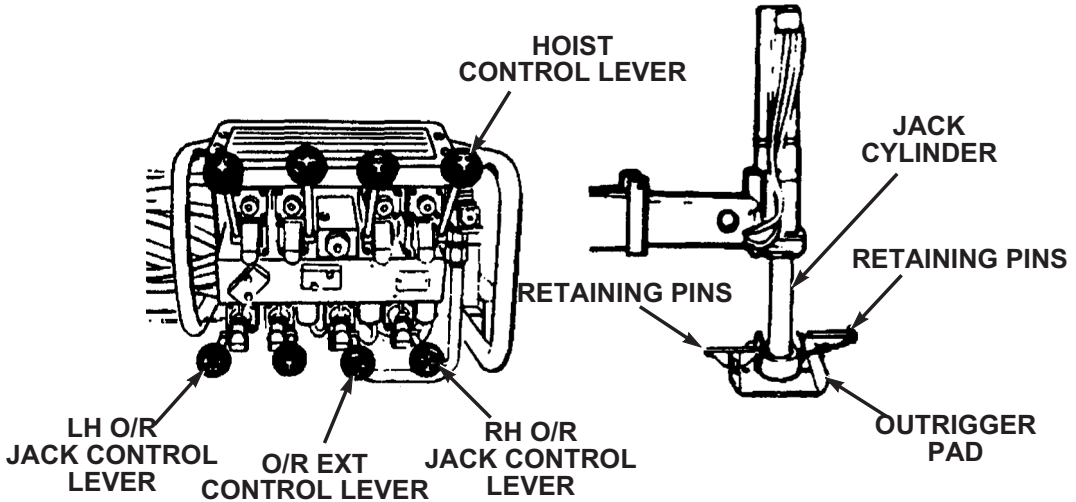

Figure 22.

		<ul style="list-style-type: none"> b. Place both outrigger lockpins in unlock position. c. Check each control separately for malfunction, proper response, obvious damage, missing parts, binding, and extreme looseness. d. Move O/R EXT lever to OUT position until both outriggers is completely extended. e. Set up outrigger pads. Check that two retaining pins are 	<p>Controls malfunction, bind, or do not respond.</p> <p>Outrigger beam does not come out.</p> <p>Retaining pin missing</p>
--	--	---	---

Table 1. PMCS - WEEKLY - Continued

Item No.	Interval	Item to be Checked or Serviced	Procedure	Equipment Not Ready/ Available If:
			<p>attached to each outrigger pad.</p> <p style="text-align: center;">WARNING</p>  <p>Keep hands and feet clear of outrigger jack cylinders. Failure to comply may result in injury or death to personnel.</p> <p style="text-align: center;">NOTE</p> <p>Adjust outrigger pad position as required so rod end will lower into pad socket.</p> <p>f. Move LH O/R JACK control lever to DOWN position and lower outrigger jack until rod end is firmly seated in outrigger pad. Install retaining pins.</p> <p>g. Move RH O/R JACK control lever to DOWN position and lower outrigger jack until rod end is firmly seated in outrigger pad. Install retaining pins.</p>	<p>from either end.</p> <p>Outrigger jack cylinder will not come out or will not lower completely into pad.</p> <p>Outrigger jack cylinder will not come out or will not lower completely into pad.</p>

Table 1. PMCS - WEEKLY - Continued

Item No.	Interval	Item to be Checked or Serviced	Procedure	Equipment Not Ready/ Available If:
			<ul style="list-style-type: none"> h. Check that outrigger jack cylinder on each side of vehicle is out and down. i. Seat outriggers. j. Raise boom to operating position: 	<p>Crane hydraulic system does not operate.</p>

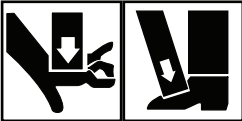
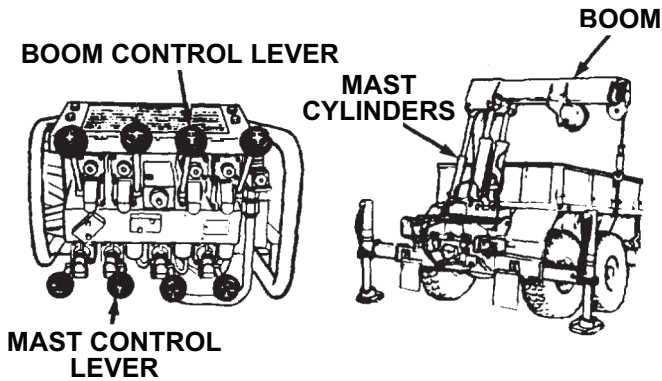

Figure 23.

		<p style="text-align: center;">WARNING</p> <div style="text-align: center;">  </div> <p>Do not operate crane unless outriggers are firmly in place or vehicle could turn over.</p>
--	--	--

Table 1. PMCS - WEEKLY - Continued

Item No.	Interval	Item to be Checked or Serviced	Procedure	Equipment Not Ready/ Available If:
			<p>Failure to comply may result in injury or death to personnel.</p> <p style="text-align: center;">CAUTION</p> <p>Do not let cable unwind and become slack, or cable may get tangled on drum.</p> <ol style="list-style-type: none"> (1) Move HOIST control lever to DOWN position until hook block rests on fender. (2) Pull and turn lockpin handle so handle end rests on bracket to unstow hook block. <p style="text-align: center;">CAUTION</p> <p>Do not allow load hook to contact taillight during inspection. Failure to comply may result in damage to equipment.</p> <p style="text-align: center;">NOTE</p> <p>Operation of vehicle with malfunctioning load hook may violate AR 385-55. (WP 0161)</p> <ol style="list-style-type: none"> (3) Check hook block and load hook for cracks, and proper operation. 	<p>Hook block or load hook is cracked.</p>

Table 1. PMCS - WEEKLY - Continued

Item No.	Interval	Item to be Checked or Serviced	Procedure	Equipment Not Ready/ Available If:
			<p style="text-align: center;">NOTE</p> <p>Operation of vehicle with malfunctioning load hook spring safety latch may violate AR 385-55. (WP 0161)</p> <p>(4) Check load hook spring safety latch for damage and proper operation.</p> <p>(5) Check hook block stowage guide wear plate for excessive wear.</p> <p style="text-align: center;">WARNING</p> <div style="text-align: center;">  </div> <p>When using crane on any vehicle, park vehicle clear of all overhead electrical lines. Keep boom clear of all electrical lines and other obstacles while operating crane. Failure to comply may result in injury or death to personnel.</p>	<p>Load hook spring safety latch doesn't open and/or close properly.</p>

Table 1. PMCS - WEEKLY - Continued

Item No.	Interval	Item to be Checked or Serviced	Procedure	Equipment Not Ready/ Available If:
			<p style="text-align: center;">CAUTION</p> <p>Do not hit outrigger leg with hook block. Failure to comply may result in damage to equipment.</p> <p>(6) Move BOOM control lever to UP position until hook is five to six feet (1.5 to 1.8 m) above driver side rear fender and boom is approximately 45° above horizontal.</p> <p>(7) Move MAST control lever to UP position until the mast is fully erect and the cylinders are fully extended. Use BOOM control lever UP simultaneously as required to maintain the boom at approximately 45° above horizontal until the mast is fully erect. Hold the MAST control lever to UP position for two to three seconds after mast is fully erect to ensure cylinders are fully filled with oil.</p> <p>k. Rotate and telescope boom:</p>	<p>Boom does not raise.</p> <p>Mast cylinder does not raise completely before stopping.</p>

Table 1. PMCS - WEEKLY - Continued

Item No.	Interval	Item to be Checked or Serviced	Procedure	Equipment Not Ready/ Available If:
			<p style="text-align: center;">WARNING</p>  <ul style="list-style-type: none"> • When using crane on any vehicle, park vehicle clear of all overhead electrical lines. Keep boom clear of all electrical lines and other obstacles while operating crane. Failure to comply may result in injury or death to personnel. • Ensure area is clear of personnel prior to moving SWING lever. Boom should be swung slowly enough so crane operator has complete control. Failure to comply may result in injury or death to personnel. <p style="text-align: center;">CAUTION</p> <p>Boom must be above vehicle sides for clearance.</p> <p>(1) Move swing control lever to CW position to move boom clockwise.</p>	<p>Boom does not turn clockwise.</p>

Table 1. PMCS - WEEKLY - Continued

Item No.	Interval	Item to be Checked or Serviced	Procedure	Equipment Not Ready/ Available If:

SWING CONTROL LEVER

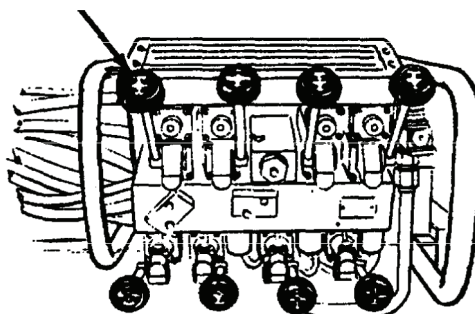

Figure 24.

- (2) Move swing control lever to CCW position to move boom counterclockwise.

Boom does not turn counterclockwise.

CAUTION

Keep hook block at least one ft. (30 cm) from end of boom. If hook block hits end of boom it may damage cable or hook block and crane will lose power. Wait six seconds for power to return and check crane for damage.

NOTE

- TELESCOPE and HOIST levers should be

Table 1. PMCS - WEEKLY - Continued

Item No.	Interval	Item to be Checked or Serviced	Procedure	Equipment Not Ready/ Available If:
			<p>operated at the same time.</p> <ul style="list-style-type: none"> Crane movement from one lever may be slower than the other when operating two levers together. <p>(3) Move TELESCOPE control lever to OUT position to extend boom while moving hoist control lever to DOWN position to pay out cable.</p>	<p>Extensions do not come out.</p>

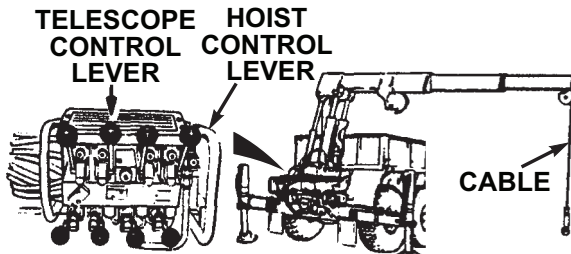

Figure 25.

		<p>(4) Check first, second, and third stages of boom for broken welds or obvious damage.</p>	<p>There are broken welds or obvious damage to boom.</p>
--	--	--	--

Table 1. PMCS - WEEKLY - Continued

Item No.	Interval	Item to be Checked or Serviced	Procedure	Equipment Not Ready/ Available If:
----------	----------	--------------------------------	-----------	------------------------------------

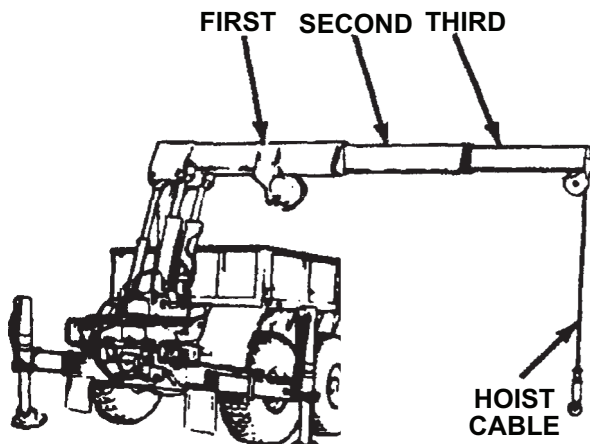

Figure 26.

WARNING



Always wear protective gloves when checking hoist cable. Never let cable run through hands. Frayed cables can cut severely. Failure to comply may result in injury or death to personnel.

- (5) Check cable on hoist for kinks, frays, or breaks.

Evidence of kinks, frays, or breaks.

Table 1. PMCS - WEEKLY - Continued

Item No.	Interval	Item to be Checked or Serviced	Procedure	Equipment Not Ready/ Available If:
			<p>(6) Check all hoses, fittings, valves, and cylinders for signs of leaks.</p> <p>(7) Check for cracked or broken welds.</p> <p>(8) Inspect turntable bearing bolts for obvious looseness.</p>	<p>Class III leak present.</p> <p>Cracked or broken welds are present.</p> <p>One or more turntable bearing bolts are loose.</p>

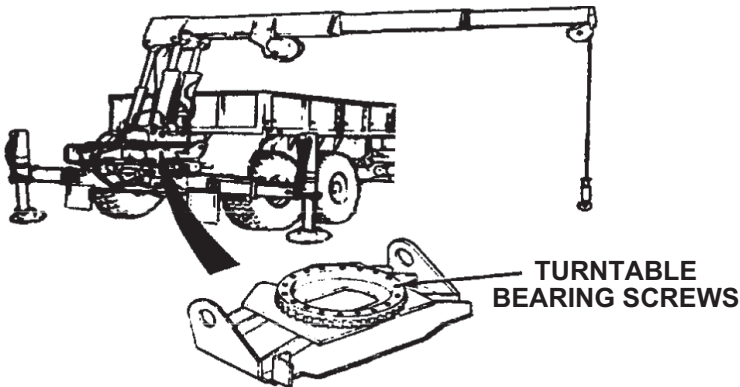

Figure 27.

CAUTION

Do not let cable become slack or cable may get tangled on drum.

Table 1. PMCS - WEEKLY - Continued

Item No.	Interval	Item to be Checked or Serviced	Procedure	Equipment Not Ready/ Available If:
			<p>(9) Move HOIST control lever in UP position to reel in cable.</p> <p>(10) Move HOIST control lever in DOWN position to pay out cable.</p> <p>NOTE</p> <p>For more information on material handling crane remote-control operating instructions, refer to grove crane operation (remote-control) procedures. (WP 0043)</p> <p>4. Check crane remote-control levers as follows:</p>	<p>Cable does not reel in.</p> <p>Cable does not pay out.</p>

Table 1. PMCS - WEEKLY - Continued

Item No.	Interval	Item to be Checked or Serviced	Procedure	Equipment Not Ready/ Available If:

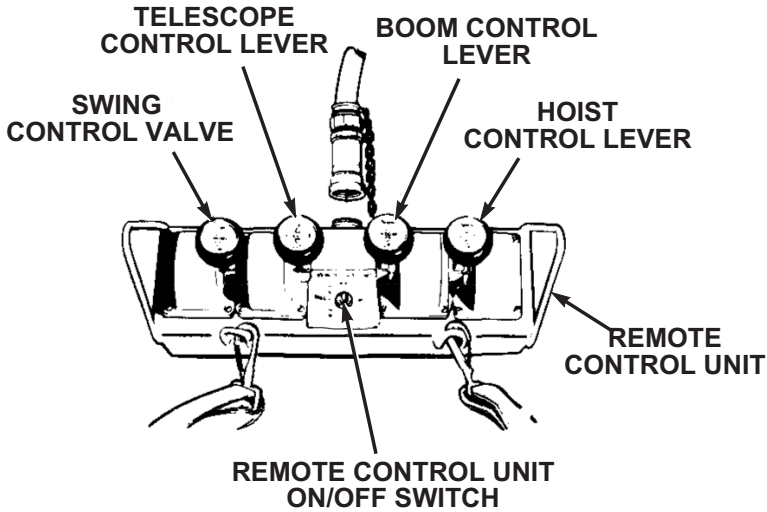

Figure 28.

- a. Set up REMOTE CONTROL UNIT passenger side. (WP 0043)

WARNING



- When using crane on any vehicle, park vehicle clear of all overhead electrical lines. Keep boom clear of all electrical lines and

Table 1. PMCS - WEEKLY - Continued

Item No.	Interval	Item to be Checked or Serviced	Procedure	Equipment Not Ready/ Available If:
			<p>other obstacles while operating crane. Failure to comply may result in injury or death to personnel.</p> <ul style="list-style-type: none"> • Ensure area is clear of personnel prior to moving SWING lever. Boom should be swung slowly enough so crane operator has complete control. Failure to comply may result in injury or death to personnel. <p>WARNING</p>  <p>If electrical power fails during crane operation, move switch on remote control unit to SHUTDOWN position. Failure to comply may result in injury or death to personnel.</p> <p>CAUTION</p> <p>Crane must be above vehicle sides for clearance.</p> <p>NOTE</p> <p>Operate control levers with light, even pressure. Moving lever slightly will cause slow</p>	

Table 1. PMCS - WEEKLY - Continued

Item No.	Interval	Item to be Checked or Serviced	Procedure	Equipment Not Ready/ Available If:
			<p>movement of crane. Moving lever to full travel will cause faster movement of crane.</p> <p>b. Check control levers for malfunction, proper response, obvious damage, missing parts, binding, and extreme looseness.</p> <p>c. Rotate and telescope boom:</p> <p style="text-align: center;">WARNING</p> <div data-bbox="603 888 727 1008" style="text-align: center;"> </div> <p>Ensure area is clear of personnel prior to moving SWING lever. Boom should be swung slowly enough so crane operator has complete control. Failure to comply may result in injury or death to personnel.</p> <p>(1) Move SWING control lever to CW position to turn boom clockwise.</p>	<p>Controls malfunction, bind, or do not respond.</p> <p>Boom does not turn clockwise.</p>

Table 1. PMCS - WEEKLY - Continued

Item No.	Interval	Item to be Checked or Serviced	Procedure	Equipment Not Ready/ Available If:

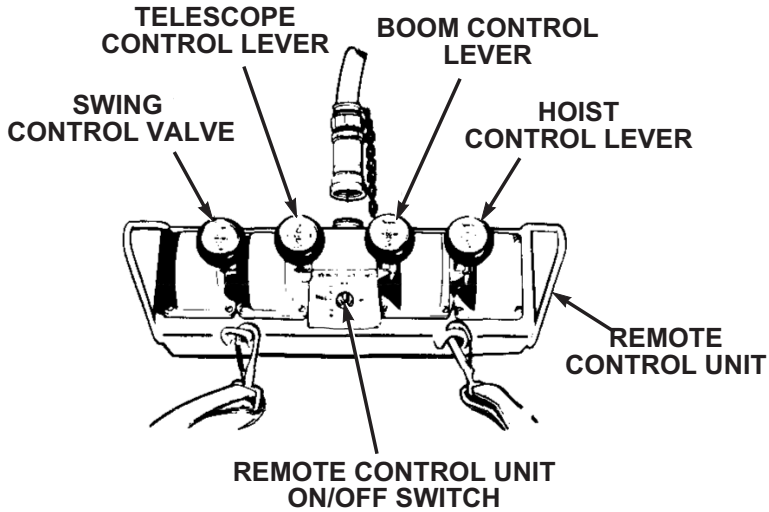

Figure 29.

- (2) Move SWING control lever to CCW position to turn boom counterclockwise.

Boom does not turn counterclockwise.

WARNING



When using crane on any vehicle, park vehicle clear of all overhead electrical lines. Keep boom clear of all elec-

Table 1. PMCS - WEEKLY - Continued

Item No.	Interval	Item to be Checked or Serviced	Procedure	Equipment Not Ready/ Available If:
			<p>trical lines and other obstacles while operating crane. Failure to comply may result in injury or death to personnel.</p> <p style="text-align: center;">CAUTION</p> <p>Do not let cable become slack or cable may get tangled on drum.</p> <p>(3) Move HOIST control lever to UP position to take up cable. Move BOOM control lever to UP position to raise boom.</p> <p>(4) Move HOIST control lever to DOWN position to pay out cable. Move BOOM control lever to DOWN position to lower boom to horizontal position.</p> <p style="text-align: center;">CAUTION</p> <ul style="list-style-type: none"> Keep hook block at least one ft. (30 cm) from end of boom. If hook block hits end of boom it may damage cable or hook block and crane will lose power. Wait six seconds for power and check crane for damage. 	<p>Cable does not reel in or boom does not raise.</p> <p>Cable does not pay out or boom does not lower.</p>

Table 1. PMCS - WEEKLY - Continued

Item No.	Interval	Item to be Checked or Serviced	Procedure	Equipment Not Ready/ Available If:
			<ul style="list-style-type: none"> • Do not let cable become slack or cable may get tangled on drum. <p style="text-align: center;">NOTE</p> <ul style="list-style-type: none"> • TELESCOPE and HOIST levers should be operated at the same time. • Crane movement from one lever may be slower than the other when operating two levers together. <p>(5) Move TELESCOPE control lever to OUT position while moving HOIST control lever to DOWN position to pay out cable.</p> <p>(6) Move HOIST control lever in UP position to reel in cable.</p> <p>(7) Check that crane and ENGINE HIGH IDLE do not operate when REMOTE CONTROL UNIT is in MHC-SHUTDOWN position. Notify organizational maintenance if crane and ENGINE HIGH IDLE</p>	<p>Extensions will not come out, or cable will not pay out.</p> <p>Cable will not reel in.</p> <p>Crane will operate and engine speed will increase to 1500 rpm.</p>

Table 1. PMCS - WEEKLY - Continued

Item No.	Interval	Item to be Checked or Serviced	Procedure	Equipment Not Ready/ Available If:
			<p>operates when in MHC-SHUTDOWN position.</p> <p>(8) Shut off remote-control switches.</p> <p>(9) Disconnect remote-control, passenger side.</p> <p>(10) Check operation of driver side remote-control station.</p> <p>(11) Connect remote-control to driver side remote-control station.</p> <p>(12) Check operation of crane remote-control levers.</p> <p>(13) Shut off remote-control switches.</p> <p>(14) Disconnect and stow REMOTE CONTROL UNIT.</p> <p>5. Shut down material handling crane.</p> <p>6. Check all hoses, fittings, valves, and cylinders for signs of leaks and damage.</p>	<p>Any Class III leak present.</p>

Table 1. PMCS - WEEKLY - Continued

Item No.	Interval	Item to be Checked or Serviced	Procedure	Equipment Not Ready/ Available If:
			7. Check for cracked or broken welds.	Cracked or broken welds.

END OF WORK PACKAGE

**OPERATOR MAINTENANCE
SEMIANNUAL - PREVENTIVE MAINTENANCE**

INITIAL SETUP:

Tools and Special Tools

Gloves, Leather (WP 0163, Table 2)

Table 1. PMCS- SEMIANNUAL



Item No.	Interval	Item to be Checked or Serviced	Procedure	Equipment Not Ready/ Available If:
			<p style="text-align: center;">WARNING</p>  <p>Do not start engine or move vehicle when personnel are under vehicle or working on brake lines. Failure to comply may result in injury or death to personnel.</p> <p style="text-align: center;">WARNING</p>  <p>Ensure engine is OFF and eye protection is worn when checking for leaks. Failure to comply may result in injury or death to personnel.</p>	

Table 1. PMCS- SEMIANNUAL - Continued

Item No.	Interval	Item to be Checked or Serviced	Procedure	Equipment Not Ready/ Available If:
1	Semian nual	Brake System	<p style="text-align: center;">NOTE</p> <ul style="list-style-type: none"> • Lubrication intervals are for normal operating conditions. Intervals may be shortened as required for severe operating conditions. • Clean all lubrication points with cleaning compound, solvent and allow to dry prior to servicing. • When using a grease gun, apply lubricant to the fitting until clean lubricant squeezes out of the part being lubricated. • Always refer to lubrication instructions (WP 0151) to ensure equipment has correct lubricants appropriate to operating environment (expected continuous temperatures). If not, remove/drain and reapply/refill equipment with appropriate lubricants for operating environment as prescribed in lubrication instructions. (WP 0151) <p>Lubricate axles No. 1, No. 2, No. 3, and No. 4 brake camshafts and slack</p>	Fitting will not purge old lubricant

Table 1. PMCS- SEMIANNUAL - Continued

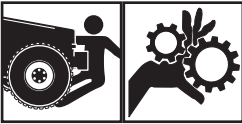
Item No.	Interval	Item to be Checked or Serviced	Procedure	Equipment Not Ready/ Available If:
			adjusters (four fittings per axle) with GAA. (WP 0151, Table 9)	out of component.

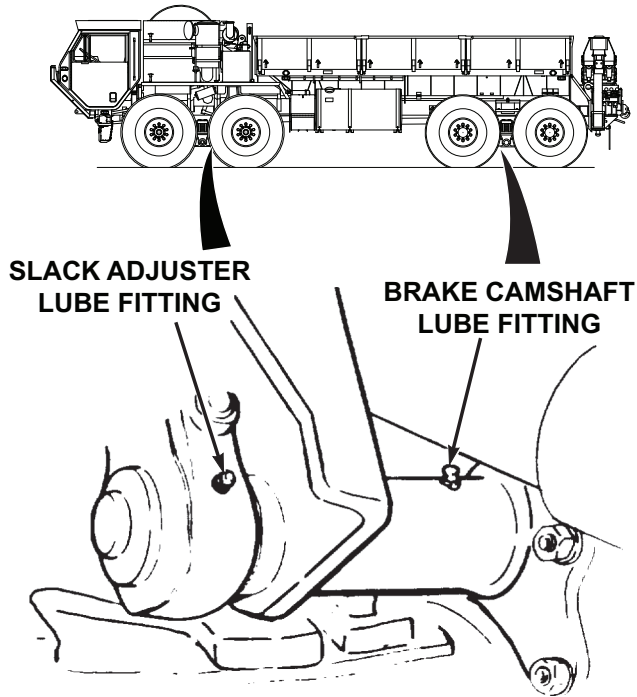

Figure 1.

NOTE

- When vehicle is operating under severe conditions, lubricate propeller shafts and universal joints every 50 hours of vehicle operation.

Table 1. PMCS- SEMIANNUAL - Continued

Item No.	Interval	Item to be Checked or Serviced	Procedure	Equipment Not Ready/ Available If:
			<ul style="list-style-type: none"> • Use the proper lubricant to purge all four bearing seals of each universal joint. This flushes abrasive contaminants from each bearing and assures all four bearings are filled properly. Pop the seals, these seals are made to be popped. • If any seals fail to purge, move propeller shaft from side-to-side while applying gun pressure. This allows greater clearance on thrust end of bearing that is not purging. If seals still do not purge, rock vehicle by releasing the parking brake, start engine, put transmission in D (drive) or R (reverse), and allow vehicle to roll. This removes the windup in the drive line and allows for a greater clearance on the thrust end of the universal joint. • Because of the design of the universal joint seal, there will occasionally be one or more bearing seals of a joint that may not purge. If this occurs, notify field level maintenance. 	

Table 1. PMCS- SEMIANNUAL - Continued

Item No.	Interval	Item to be Checked or Serviced	Procedure	Equipment Not Ready/ Available If:
2	Semian nual	Propeller Shafts and U-Joints	<ul style="list-style-type: none"> • Universal joint may have one or two grease fittings. If there are two grease fittings, either fitting can be greased. It is not necessary to grease both fittings. <ol style="list-style-type: none"> 1. Lubricate all axle propeller shafts, transmission to transfer case propeller shaft, and U-joints with GAA: (WP 0151, Table 9) 	Fitting will not purge old lubricant out of component.

Table 1. PMCS- SEMIANNUAL - Continued

Item No.	Interval	Item to be Checked or Serviced	Procedure	Equipment Not Ready/ Available If:
----------	----------	--------------------------------	-----------	------------------------------------

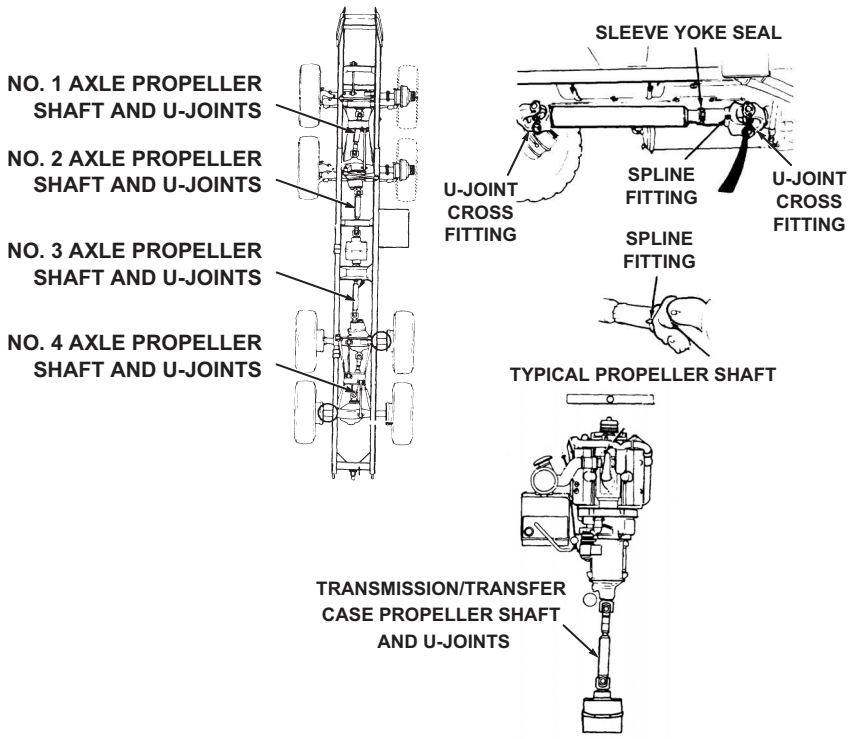

Figure 2.

		<p>a. Complete the following when lubricating the spline end of the propeller shafts:</p> <p>(1) Apply GAA (WP 0151, Table 9) to spline fitting</p>	<p>Fitting will not purge old lubricant out of component.</p>
--	--	---	---

Table 1. PMCS- SEMIANNUAL - Continued

Item No.	Interval	Item to be Checked or Serviced	Procedure	Equipment Not Ready/ Available If:
3	Semian nual	Steering System	<p>until lubricant appears at pressure relief hole.</p> <p>(2) Cover pressure relief hole with finger and continue adding grease until it appears at sleeve yoke seal.</p> <p>1. Lubricate intergear link with GAA. (WP 0151, Table 9)</p>	<p>Fitting will not purge old lubricant out of component.</p>

Table 1. PMCS- SEMIANNUAL - Continued

Item No.	Interval	Item to be Checked or Serviced	Procedure	Equipment Not Ready/ Available If:
----------	----------	--------------------------------	-----------	------------------------------------

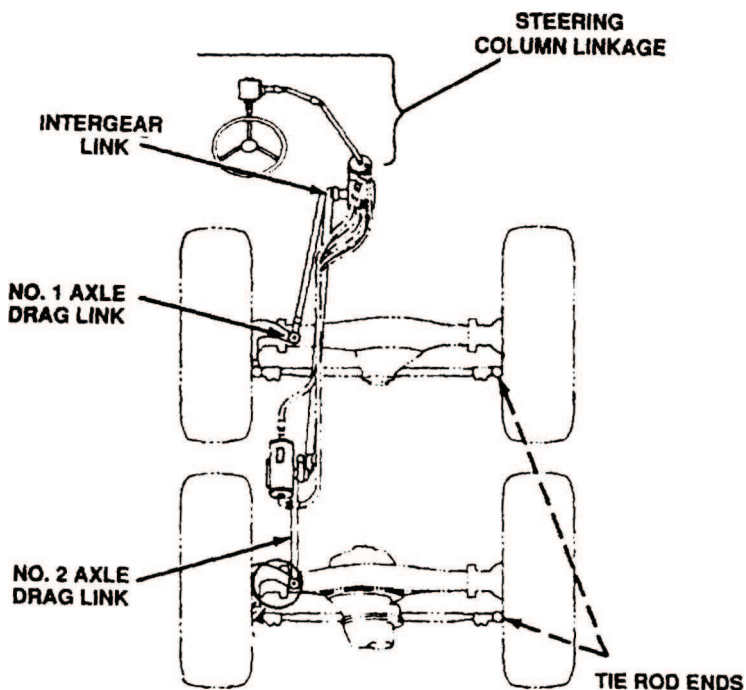

Figure 3.

		<ol style="list-style-type: none"> 2. Lubricate No. 1 axle drag link with GAA. (WP 0151, Table 9) 3. Lubricate No. 2 axle drag link with GAA. (WP 0151, Table 9) 	<p>Fitting will not purge old lubricant out of component.</p> <p>Fitting will not purge old lubricant</p>
--	--	--	---

Table 1. PMCS- SEMIANNUAL - Continued

Item No.	Interval	Item to be Checked or Serviced	Procedure	Equipment Not Ready/ Available If:
			<p>4. Lubricate tie rod ends with GAA. (WP 0151, Table 9)</p> <p>5. Lubricate steering linkage U-joints and shafts with GAA. (WP 0151)</p> <p style="text-align: center;">NOTE</p> <ul style="list-style-type: none"> • The top trunnion bearing should be given 10 to 12 strokes with a grease gun through existing fitting. • The plug below the bottom should temporarily be removed and a grease fitting installed. The lower trunnion bearing should be lubricated with 10 to 12 strokes from a grease gun. The grease fitting should then be removed and the plug reinstalled. <p>6. Lubricate No. 1 and No. 2 axle trunnion bearings with GAA. (WP 0151, Table 9)</p>	<p>out of component.</p> <p>Fitting will not purge old lubricant out of component.</p> <p>Fitting will not purge old lubricant out of component.</p>

Table 1. PMCS- SEMIANNUAL - Continued

Item No.	Interval	Item to be Checked or Serviced	Procedure	Equipment Not Ready/ Available If:
----------	----------	--------------------------------	-----------	------------------------------------

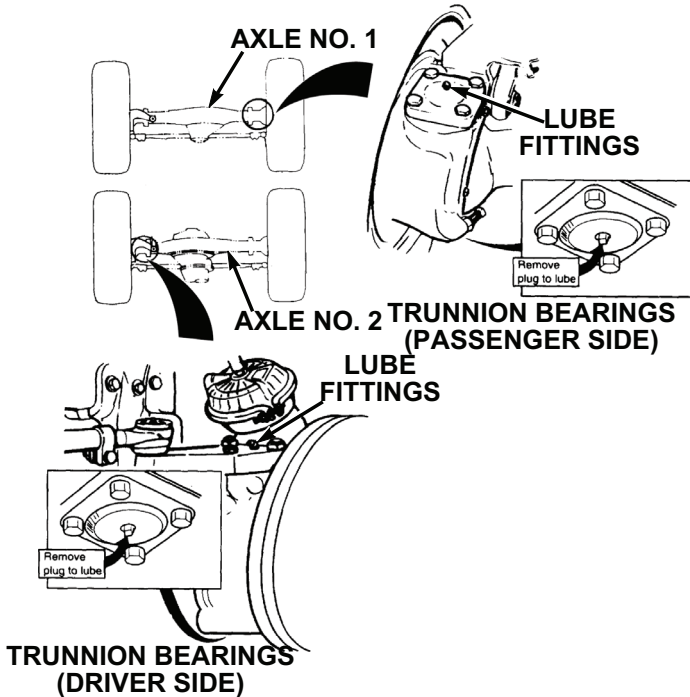

Figure 4.

4	Semianual	Spring Hanger	1. Lubricate spring hanger pivot points (one fitting per spring) with GAA. (WP 0151, Table 9)	Fitting will not purge old lubricant out of component.
---	-----------	---------------	---	--

Table 1. PMCS- SEMIANNUAL - Continued

Item No.	Interval	Item to be Checked or Serviced	Procedure	Equipment Not Ready/ Available If:
----------	----------	--------------------------------	-----------	------------------------------------

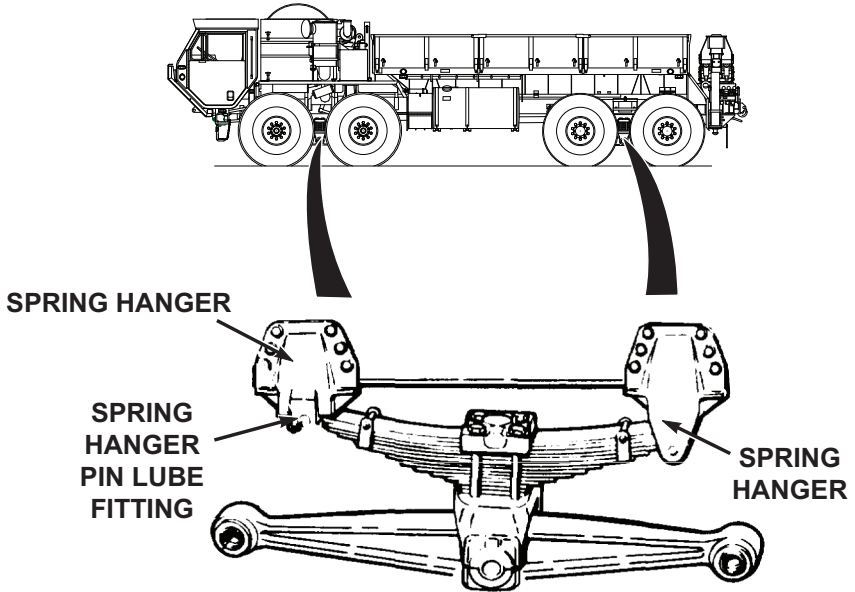

Figure 5.

	<ol style="list-style-type: none"> 2. If spring hanger pin does not accept grease, perform the following: <ol style="list-style-type: none"> a. Relieve load on spring hanger pin by jacking up vehicle at frame rails, as close to spring hanger pin as possible. b. Lubricate spring hanger pin pivot.
--	--

Table 1. PMCS- SEMIANNUAL - Continued

Item No.	Interval	Item to be Checked or Serviced	Procedure	Equipment Not Ready/ Available If:
5	Semianual	Battery Electrical System	<p>c. If springer hanger pin still fails to take grease, notify field level maintenance to remove spring hanger pin and replace as necessary.</p> <p>Coat slave receptacle with corrosion preventive compound.</p>	

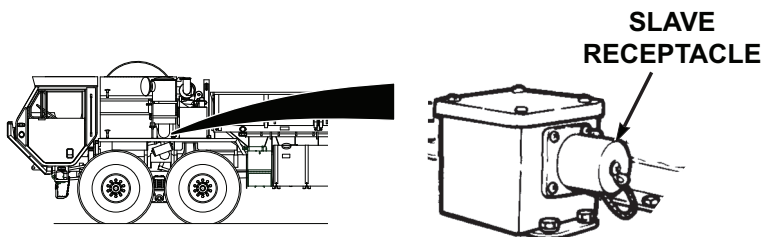

Figure 6.

6	Semianual	Mirror Assemblies	Lubricate mirror assembly swivel joints with GAA. (WP 0151, Table 9)	
---	-----------	-------------------	--	--

Table 1. PMCS- SEMIANNUAL - Continued

Item No.	Interval	Item to be Checked or Serviced	Procedure	Equipment Not Ready/ Available If:
----------	----------	--------------------------------	-----------	------------------------------------

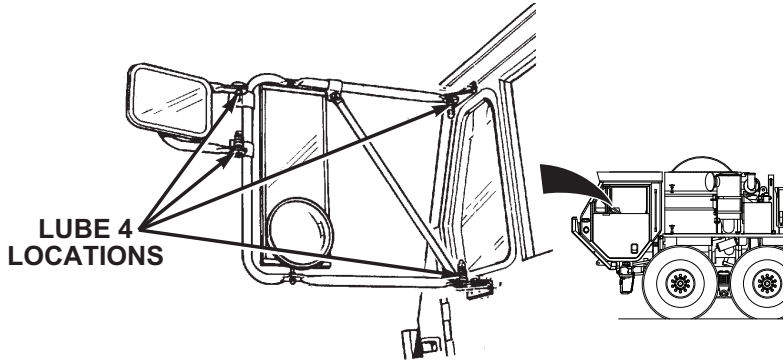

Figure 7.

7	Semian nual	Pintle Hook	<p style="text-align: center;">NOTE</p> <p>Pintle hook plate lubrication fitting can be on any side.</p> <ol style="list-style-type: none"> Lubricate pintle hook (3 fittings) with GAA. (WP 0151, Table 9) 	Fitting will not purge old lubricant out of component.
---	-------------	-------------	---	--

Table 1. PMCS- SEMIANNUAL - Continued

Item No.	Interval	Item to be Checked or Serviced	Procedure	Equipment Not Ready/ Available If:
----------	----------	--------------------------------	-----------	------------------------------------

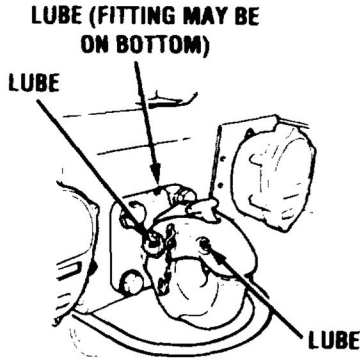

Figure 8.

NOTE

Lubricate outrigger bottom plate, boom wear pads, and exposed rotation gears often when cranes are operating in sandy/dusty environment.

8	Semianual	Crane (Grove)	<ol style="list-style-type: none"> Lubricate pivots at both ends of lift cylinders (eight fittings) with GAA. (WP 0151, Table 7) 	Fitting will not purge old lubricant out of component.
---	-----------	---------------	---	--

Table 1. PMCS- SEMIANNUAL - Continued

Item No.	Interval	Item to be Checked or Serviced	Procedure	Equipment Not Ready/ Available If:
----------	----------	--------------------------------	-----------	------------------------------------

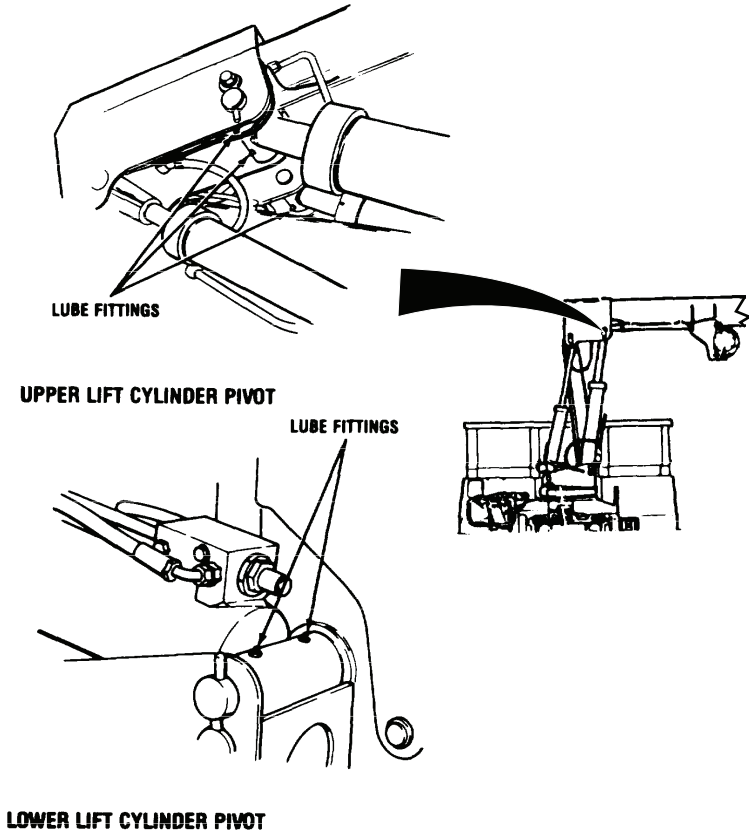

Figure 9.

		<p>2. Lubricate mast pivots (four fittings) with GAA. (WP 0151, Table 7)</p>	<p>Fitting will not purge old lubricant out of component.</p>
--	--	--	---

Table 1. PMCS- SEMIANNUAL - Continued

Item No.	Interval	Item to be Checked or Serviced	Procedure	Equipment Not Ready/ Available If:
----------	----------	--------------------------------	-----------	------------------------------------

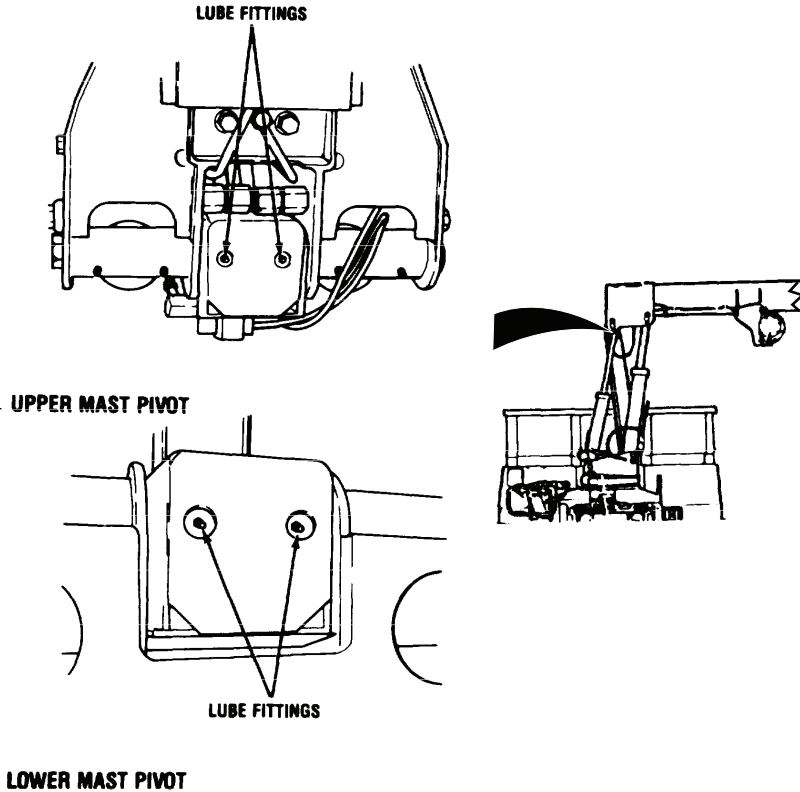

Figure 10.

		<p>3. Lubricate pivots at both ends of erection cylinders (eight fittings) with GAA. (WP 0151, Table 7)</p>	<p>Fitting will not purge old lubricant out of component.</p>
--	--	---	---

Table 1. PMCS- SEMIANNUAL - Continued

Item No.	Interval	Item to be Checked or Serviced	Procedure	Equipment Not Ready/ Available If:
----------	----------	--------------------------------	-----------	------------------------------------

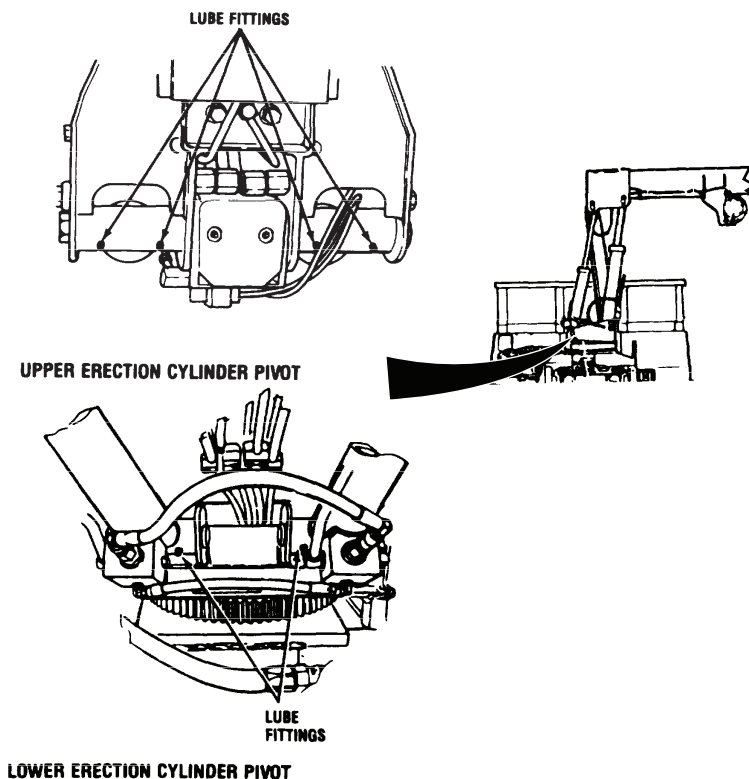

Figure 11.

NOTE

Always re-lubricate rotation gear and pinion teeth after high pressure wash.

Table 1. PMCS- SEMIANNUAL - Continued

Item No.	Interval	Item to be Checked or Serviced	Procedure	Equipment Not Ready/ Available If:
			4. Check and lubricate rotation gear and pinion teeth with light coat of GAA. (WP 0151, Table 7)	Gear teeth broken/ missing.

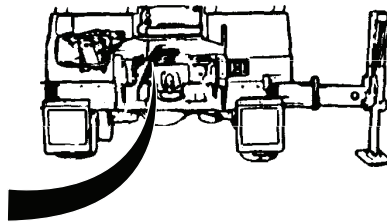
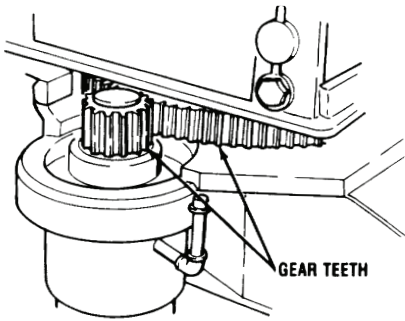

ROTATION GEAR BEARING AND PINION TEETH

Figure 12.

		5. Clean and lubricate boom wear pads with GAA. (WP 0151, Table 7)
--	--	--

Table 1. PMCS- SEMIANNUAL - Continued

Item No.	Interval	Item to be Checked or Serviced	Procedure	Equipment Not Ready/ Available If:
----------	----------	--------------------------------	-----------	------------------------------------

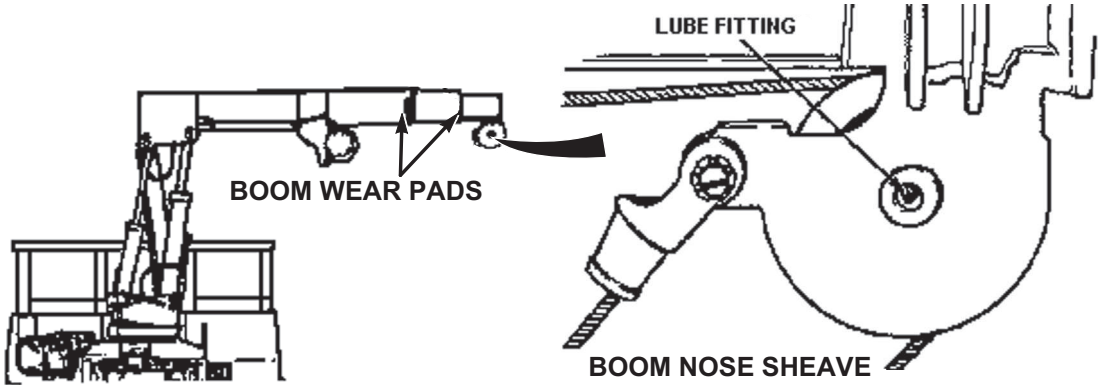

Figure 13.

		<ol style="list-style-type: none"> 6. Lubricate boom nose sheave bushing (one fitting) with GAA. (WP 0151, Table 7) 7. Lubricate hook block clevis pivot point with OE/HDO. (WP 0151, Table 8) 	<p>Fitting will not purge old lubricant out of component.</p>
--	--	--	---

Table 1. PMCS- SEMIANNUAL - Continued

Item No.	Interval	Item to be Checked or Serviced	Procedure	Equipment Not Ready/ Available If:

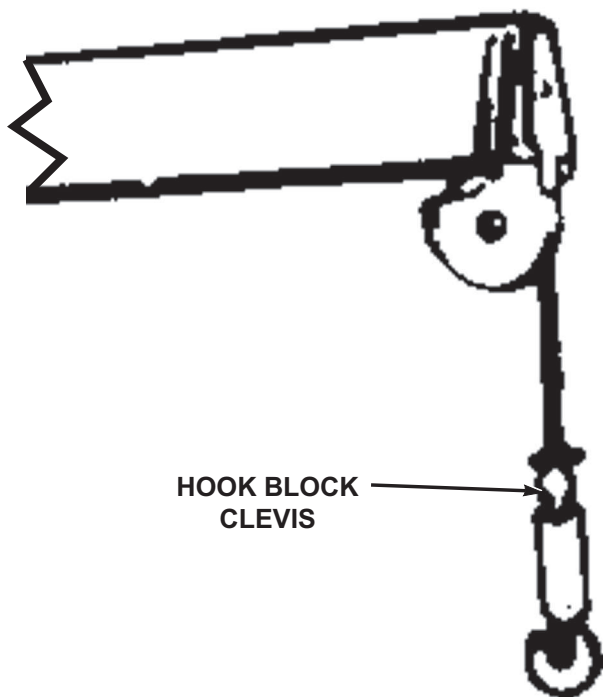

Figure 14.

NOTE

Raise crane mast until lube fitting comes into view. Turn and lubricate turntable every 90° until you have turned the turntable 360°, then rotate

Table 1. PMCS- SEMIANNUAL - Continued

Item No.	Interval	Item to be Checked or Serviced	Procedure	Equipment Not Ready/ Available If:
			crane a full 360° to spread lubricant. 8. Lubricate turntable bearing (one fitting) with GAA. (WP 0151, Table 7)	Fitting will not purge old lubricant out of component.

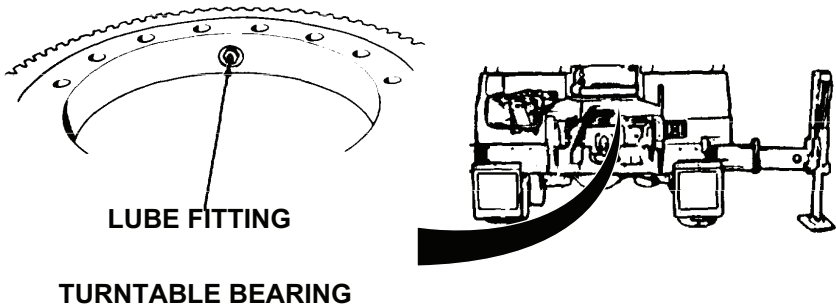

Figure 15.

		9. Clean and lubricate sliding surfaces of outrigger bottom plates with GAA. (WP 0151, Table 7)
--	--	---

Table 1. PMCS- SEMIANNUAL - Continued

Item No.	Interval	Item to be Checked or Serviced	Procedure	Equipment Not Ready/ Available If:

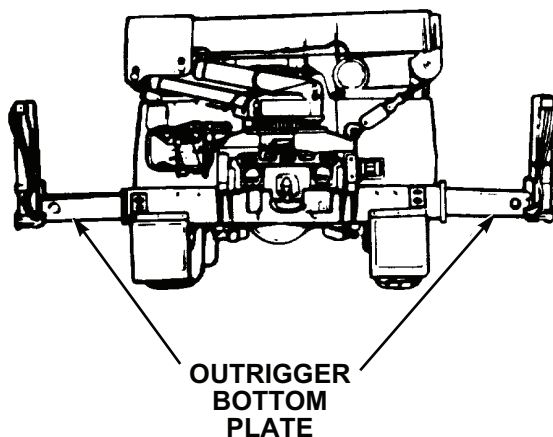

Figure 16.

WARNING



Always wear protective gloves when checking hoist cable. Never let cable run through hands. Frayed cables can cut severely. Failure to comply may result in injury or death to personnel.

Table 1. PMCS- SEMIANNUAL - Continued

Item No.	Interval	Item to be Checked or Serviced	Procedure	Equipment Not Ready/ Available If:
9	Semianual	Crane Hoist Cable	<ol style="list-style-type: none"> 1. Unreel crane hoist cable and check hoist cable for kinks, broken strands, and wear. 2. Clean and lubricate hoist cable with OE/HDO. (WP 0151, Table 7) 	<p>Kinks, broken strands, or wear present.</p> <p>Kinks, broken strands, or wear present.</p>
10	Semianual	Self-Recovery Winch	<ol style="list-style-type: none"> 1. Unreel, (WP 0087) clean, and lubricate cable with OE/HDO. (WP 0151, Table 6) 2. Lubricate front and rear cable tensioner rollers (three fittings per tensioner) with GAA. (WP 0151, Table 9) 	<p>Fitting will not purge old lubricant out of component.</p>

Table 1. PMCS- SEMIANNUAL - Continued

Item No.	Interval	Item to be Checked or Serviced	Procedure	Equipment Not Ready/ Available If:
----------	----------	--------------------------------	-----------	------------------------------------

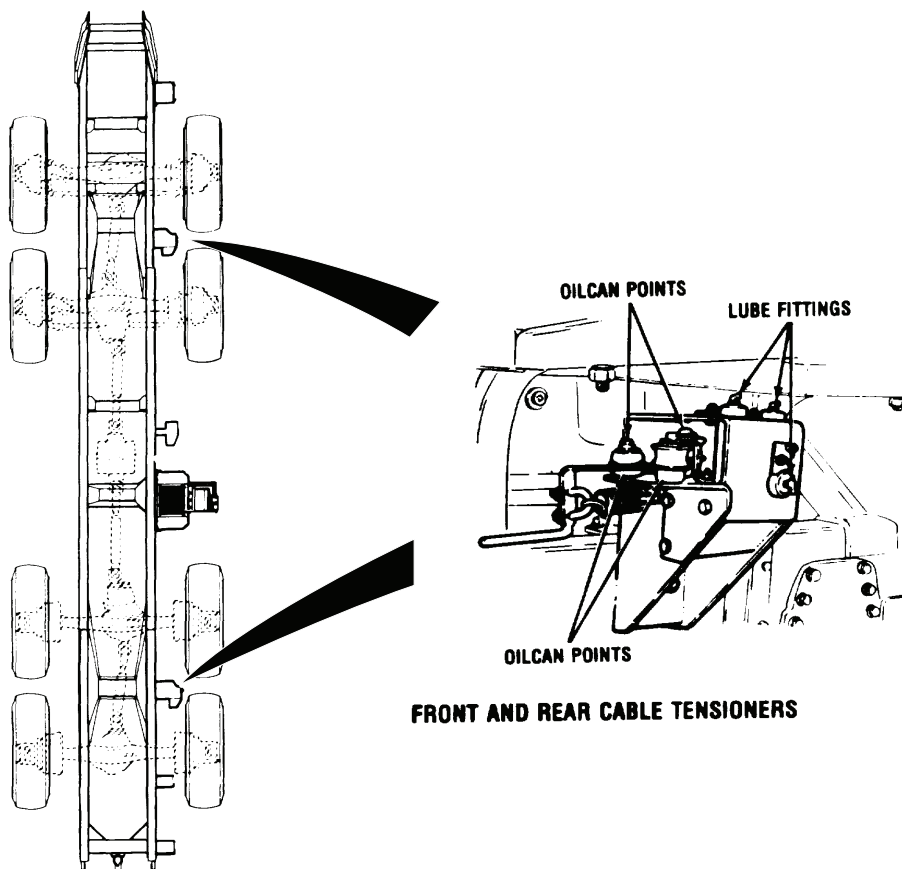

Figure 17.

- | | | |
|--|--|--|
| | | <ol style="list-style-type: none"> 3. Lubricate pivot points and pressure rollers with OE/HDO. (WP 0151, Table 8) |
|--|--|--|

Table 1. PMCS- SEMIANNUAL - Continued

Item No.	Interval	Item to be Checked or Serviced	Procedure	Equipment Not Ready/ Available If:
			4. Lubricate rear cable guide roller (four fittings) with GAA. (WP 0151, Table 9)	Fitting will not purge old lubricant out of component.

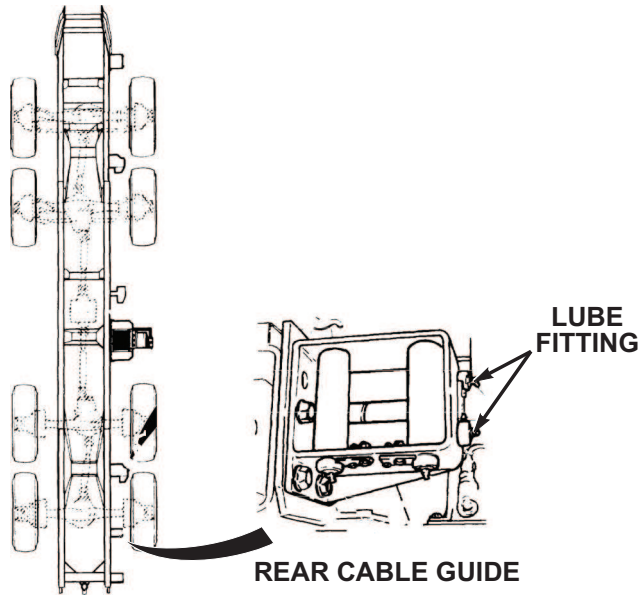

Figure 18.

		5. Lubricate front cable guide (four fittings) with GAA. (WP 0151, Table 9)	Fitting will not purge old lubricant
--	--	---	--------------------------------------

Table 1. PMCS- SEMIANNUAL - Continued

Item No.	Interval	Item to be Checked or Serviced	Procedure	Equipment Not Ready/ Available If:
				out of component.

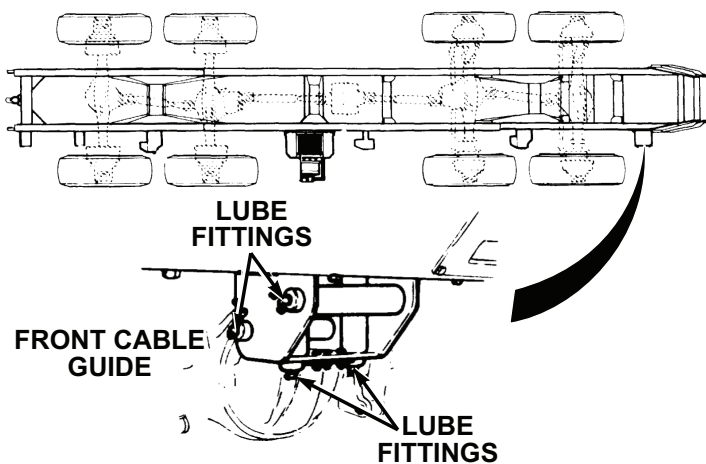

Figure 19.

11	Semianual	Spare Tire Davit	1. Lubricate tire davit pivot point with light coating of GAA. (WP 0151, Table 9)
----	-----------	------------------	---

Table 1. PMCS- SEMIANNUAL - Continued

Item No.	Interval	Item to be Checked or Serviced	Procedure	Equipment Not Ready/ Available If:
----------	----------	--------------------------------	-----------	------------------------------------

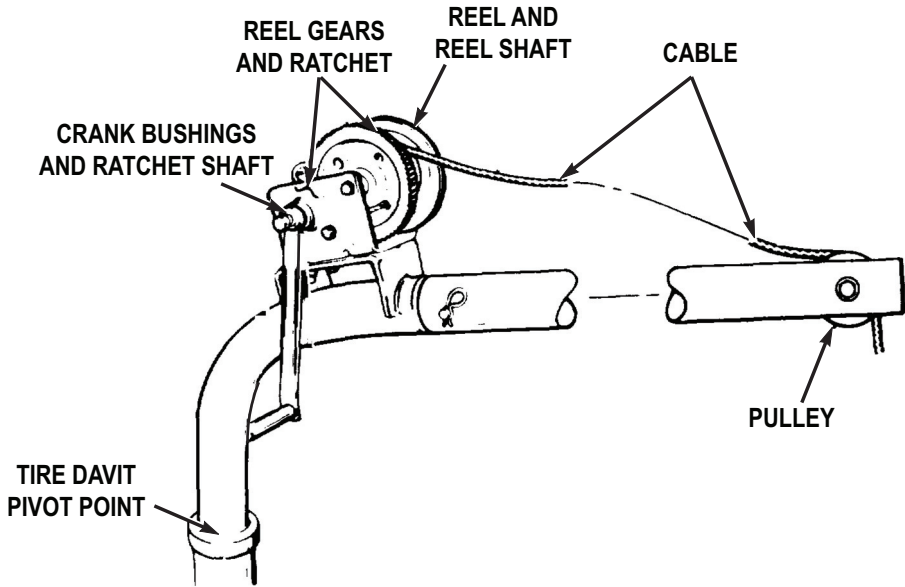

Figure 20.

		<ol style="list-style-type: none"> 2. Lubricate reel gears and ratchet with light coating of GAA. (WP 0151, Table 9) 3. Lubricate crank bushings and ratchet shaft with OE/HDO. (WP 0151, Table 8) 4. Lubricate reel and reel shaft with OE/HDO. (WP 0151, Table 8) 5. Lubricate cable with OE/HDO. (WP 0151, Table 8)
--	--	--

Table 1. PMCS- SEMIANNUAL - Continued

Item No.	Interval	Item to be Checked or Serviced	Procedure	Equipment Not Ready/ Available If:
			6. Lubricate pulley with OE/HDO. (WP 0151, Table 8)	

END OF WORK PACKAGE

**OPERATOR MAINTENANCE
MONTHLY - PREVENTIVE MAINTENANCE**

INITIAL SETUP:

Tools and Special Tools

Gloves, Leather (WP 0163, Table 2)

Table 1. PMCS - MONTHLY



Item No.	Interval	Item to be Checked or Serviced	Procedure	Equipment Not Ready/ Available If:
			<p style="text-align: center;">WARNING</p>  <p>Do not start engine or move vehicle when personnel are under vehicle or working on brake lines. Failure to comply may result in injury or death to personnel.</p> <p style="text-align: center;">WARNING</p>  <p>Ensure engine is OFF and eye protection is worn when checking for leaks. Failure to comply may result in injury or death to personnel.</p>	

Table 1. PMCS - MONTHLY - Continued

Item No.	Interval	Item to be Checked or Serviced	Procedure	Equipment Not Ready/ Available If:
1	Monthly	Damage And	<p style="text-align: center;">NOTE</p> <ul style="list-style-type: none"> • Lubrication intervals are for normal operating conditions. Intervals may be shortened as required for severe operating conditions. • Clean all lubrication points with cleaning compound, solvent and allow to dry prior to servicing. • When using a grease gun, apply lubricant to the fitting until clean lubricant squeezes out of the part being lubricated. • Always refer to lubrication instructions (WP 0151) to ensure equipment has correct lubricants appropriate to operating environment (expected continuous temperatures). If not, remove/drain and reapply/refill equipment with appropriate lubricants for operating environment as prescribed in lubrication instructions. (WP 0151) <p>Check entire vehicle for obvious damage and/or corrosion.</p>	Any broken, cracked, bent frame

Table 1. PMCS - MONTHLY - Continued

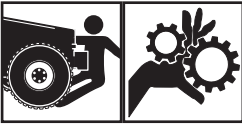
Item No.	Interval	Item to be Checked or Serviced	Procedure	Equipment Not Ready/ Available If:
2	Monthly	Corrosion Check Lubricate Oilcan Points	<ol style="list-style-type: none"> 1. Lubricate cabin door latching mechanisms and hinges with OE/HDO. (WP 0151) 2. Lubricate all side panel and engine cover hinges, locks, and latches with OE/HDO. (WP 0151) <p style="text-align: center;">NOTE</p> <p>Steady illumination of the arctic engine heater indicator light indicates proper operation.</p>	rails, cross-members, or screws are found.
3	Monthly	Arctic Engine Heater	<ol style="list-style-type: none"> 1. Position arctic engine heater ON/OFF switch to ON position, indicator light will illuminate. 	

Table 1. PMCS - MONTHLY - Continued

Item No.	Interval	Item to be Checked or Serviced	Procedure	Equipment Not Ready/ Available If:

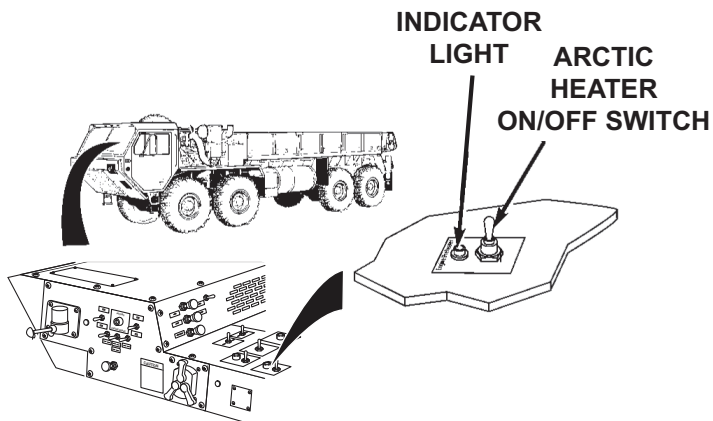

Figure 1.

		<p>2. Visually check all fuel lines for leaks, cuts, loose clamps, and other obvious damage.</p>	<p>Any Class III leak.</p>
--	--	--	----------------------------

Table 1. PMCS - MONTHLY - Continued

Item No.	Interval	Item to be Checked or Serviced	Procedure	Equipment Not Ready/ Available If:
----------	----------	--------------------------------	-----------	------------------------------------

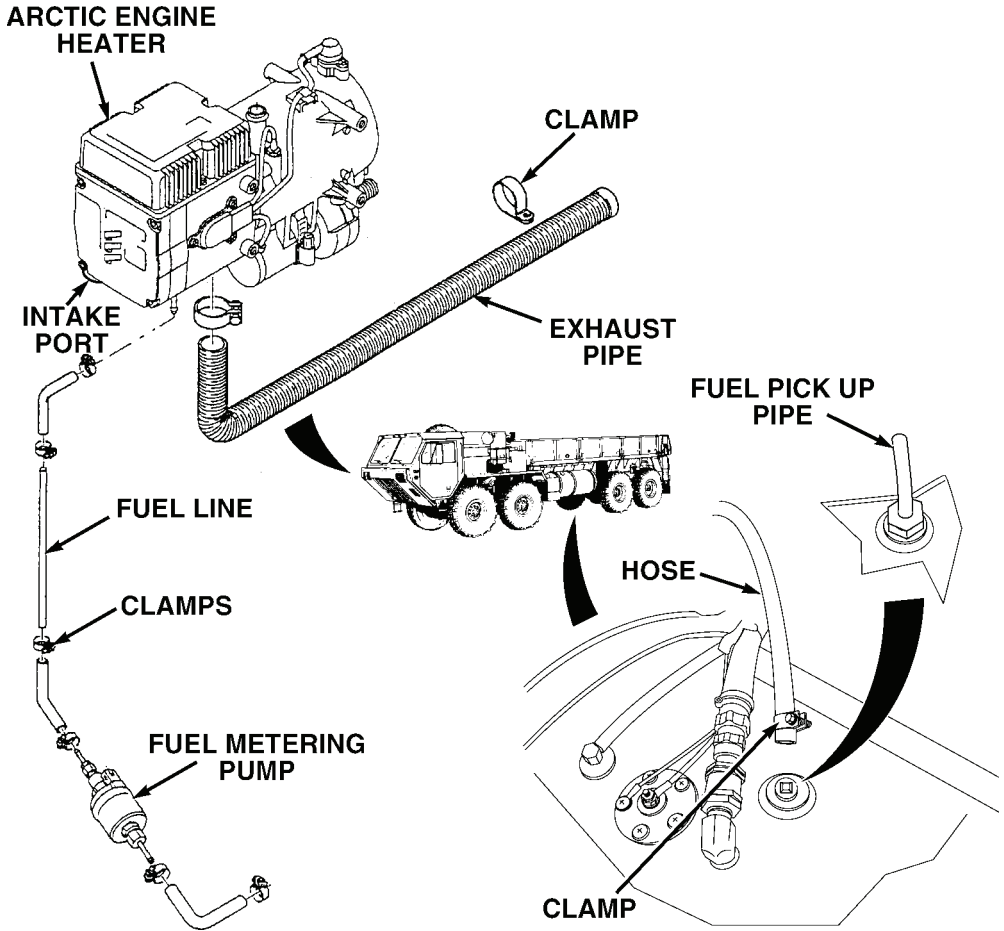

Figure 2.

3. Visually check intake port and exhaust pipe for blockage.

Table 1. PMCS - MONTHLY - Continued

Item No.	Interval	Item to be Checked or Serviced	Procedure	Equipment Not Ready/ Available If:
			4. Check water pump for unusual noise.	

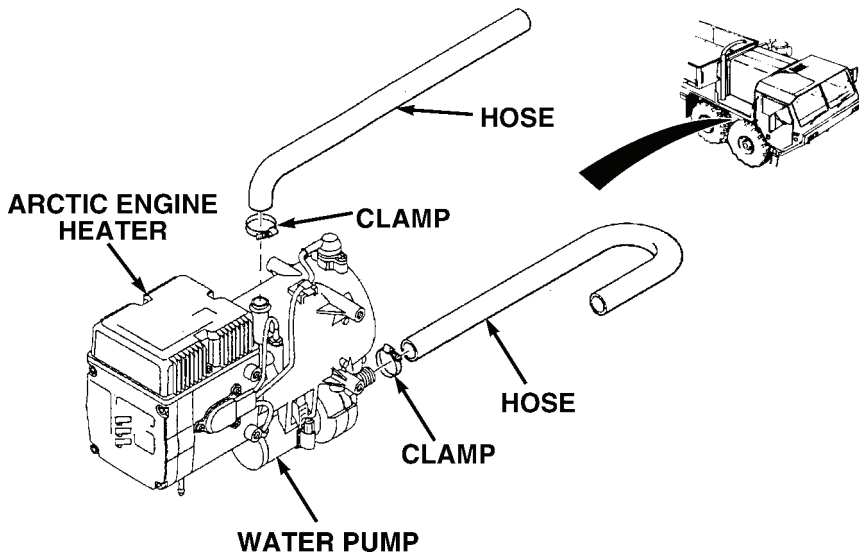

Figure 3.

			5. Check coolant hoses at arctic engine heater for leaks, cuts, loose hose clamps, and other obvious damage.	Any Class III leak.
			6. Check coolant hoses and fittings at passenger side of engine for leaks, cuts, loose hose clamps, and other obvious damage.	Any Class III leak.

Table 1. PMCS - MONTHLY - Continued

Item No.	Interval	Item to be Checked or Serviced	Procedure	Equipment Not Ready/ Available If:
----------	----------	--------------------------------	-----------	------------------------------------

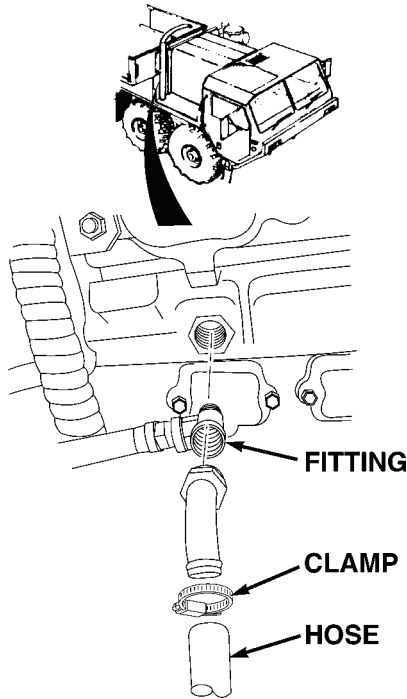

Figure 4.

- | | | | |
|--|--|--|----------------------------|
| | | <p>7. Check coolant hoses and fittings at passenger side of engine for leaks, cuts, loose hose clamps, and other obvious damage.</p> | <p>Any Class III leak.</p> |
|--|--|--|----------------------------|

Table 1. PMCS - MONTHLY - Continued

Item No.	Interval	Item to be Checked or Serviced	Procedure	Equipment Not Ready/ Available If:
----------	----------	--------------------------------	-----------	------------------------------------

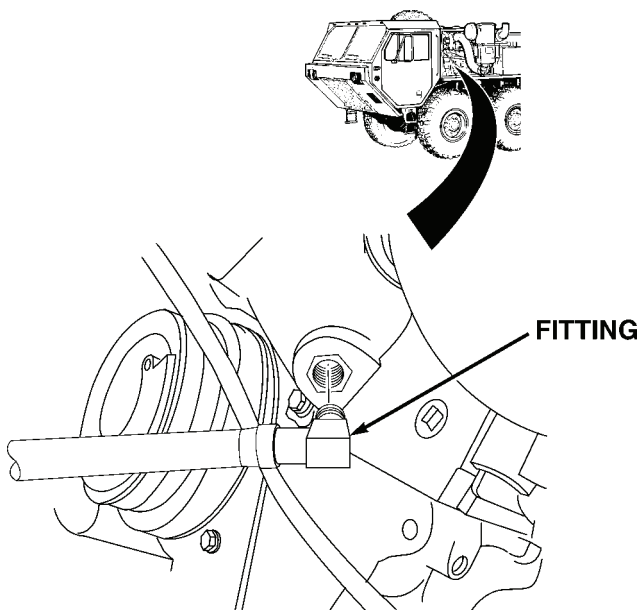

Figure 5.

4	Monthly	Crane Control Levers	<ol style="list-style-type: none"> 8. Run arctic engine heater for a minimum of 15 minutes at least once a month. 1. Lubricate crane control lever pivots with OE/HDO. (WP 0151, Table 8) 	
---	---------	----------------------	---	--

Table 1. PMCS - MONTHLY - Continued

Item No.	Interval	Item to be Checked or Serviced	Procedure	Equipment Not Ready/ Available If:
----------	----------	--------------------------------	-----------	------------------------------------

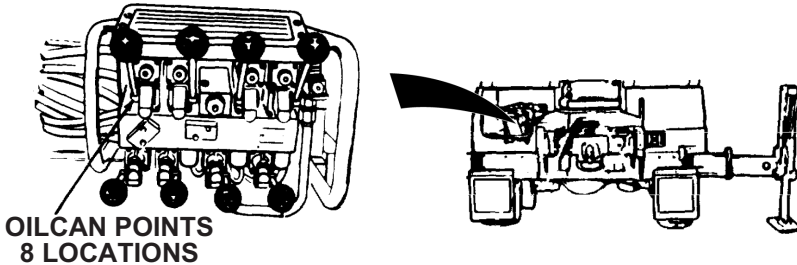

Figure 6.

WARNING



- Always wear protective gloves when handling winch cable. Never let cable run through hands. Frayed cables can cut severely. Failure to comply may result in injury or death to personnel.
- Never operate winch with less than five wraps of cable on winch drum. Failure to comply may result in injury or death to personnel.

Table 1. PMCS - MONTHLY - Continued

Item No.	Interval	Item to be Checked or Serviced	Procedure	Equipment Not Ready/ Available If:
5	Monthly	Self-Recovery Winch (SRW)	<ol style="list-style-type: none"> 1. Check winch cable for kinks, frays, and breaks. 2. Check self-recovery winch (SRW) lever (WP 0020) for proper operation in both directions. 	Self-recovery winch (SRW) lever does not function.

Table 1. PMCS - MONTHLY - Continued

Item No.	Interval	Item to be Checked or Serviced	Procedure	Equipment Not Ready/ Available If:
----------	----------	--------------------------------	-----------	------------------------------------

REAR CABLE GUIDE

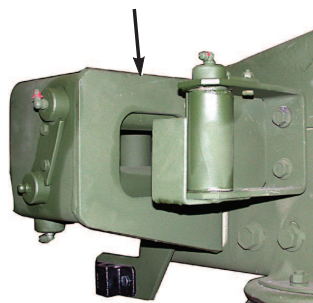

FRONT CABLE GUIDE

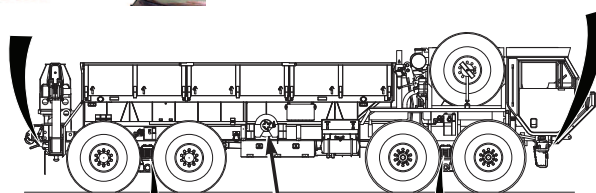
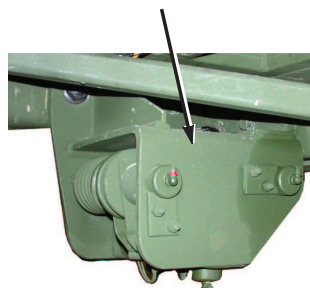

REAR TENSIONER



SELF-RECOVERY WINCH

FRONT TENSIONER

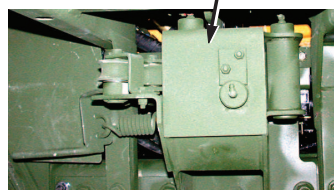

Figure 7.

3. Inspect front cable guide for any loose or missing parts and any obvious damage.

Front cable guide has loose/missing parts or

Table 1. PMCS - MONTHLY - Continued

Item No.	Interval	Item to be Checked or Serviced	Procedure	Equipment Not Ready/ Available If:
6	Monthly	Gas Particulate Filter Unit (GPFU)	<p>4. Inspect front tensioner for loose or missing parts and any obvious damage.</p> <p>5. Inspect rear tensioner for loose or missing parts and any other obvious damage.</p> <p>6. Inspect rear cable guide for loose or missing parts and any obvious damage.</p> <p style="text-align: center;">NOTE</p> <p>Gas particulate filter unit must be in operation (WP 0059) to perform the following checks.</p> <p>1. Check heater for unusual loud noise or improper operation.</p>	<p>is unserviceable.</p> <p>Front tensioner has loose/missing parts or is unserviceable.</p> <p>Rear tensioner has loose/missing parts or is unserviceable.</p> <p>Rear cable guide has loose/missing parts or is unserviceable.</p> <p>Heater does not operate/operates abnormally and GPFU is required for mission.</p>

Table 1. PMCS - MONTHLY - Continued

Item No.	Interval	Item to be Checked or Serviced	Procedure	Equipment Not Ready/ Available If:
----------	----------	--------------------------------	-----------	------------------------------------

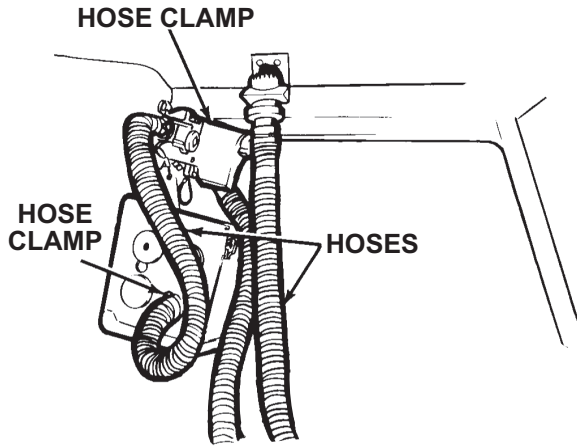

Figure 8.

		<ol style="list-style-type: none"> 2. Disconnect two air duct breakaway sockets from mount and feel for airflow. 3. Turn heater control knob clockwise to make sure indicator light illuminates. 4. Check hoses for cuts, tears, and other obvious damage. 	<p>No airflow or not enough air-flow and GPFU is required for mission.</p> <p>Heater is in-operative and GPFU is required for mission.</p> <p>Hoses cut, torn, or damaged and GPFU</p>
--	--	---	--

Table 1. PMCS - MONTHLY - Continued

Item No.	Interval	Item to be Checked or Serviced	Procedure	Equipment Not Ready/ Available If:
7	Monthly	Rifle Stowage Mount	<ol style="list-style-type: none"> 1. Check that mounting screws on top mount and lower mount are not broken or missing. 5. Make sure hose clamps are secure. 	<p>is required for mission.</p> <p>Clamps loose and GPFU is required for mission.</p>

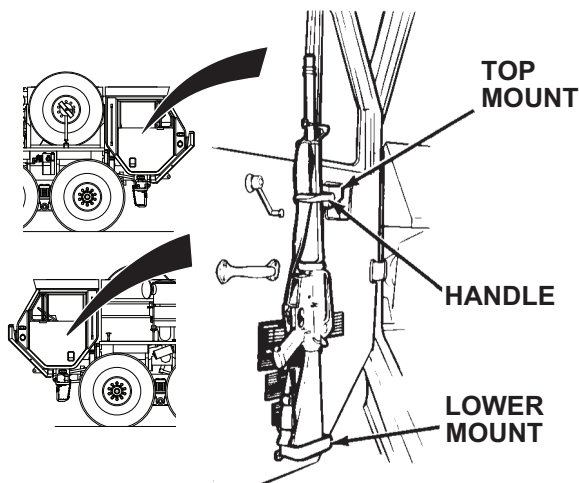

Figure 9.

		<ol style="list-style-type: none"> 2. Check handle for excessive looseness or binding.
--	--	---

Table 1. PMCS - MONTHLY - Continued

Item No.	Interval	Item to be Checked or Serviced	Procedure	Equipment Not Ready/ Available If:
8	Monthly	Machine Gun Operator's Platform Support	Check machine gun operator's platform support for loose, broken, or missing mounting screws.	
9	Monthly	Machine Gun Operator's Platform	Check machine gun operator's platform for cracks, loose or broken leg, missing or broken tie down strap.	
10	Monthly	Ring Mount	Check machine gun mounts for loose, broken, or missing mounting screws.	
11	Monthly	M-13 Decontamination Unit	Refer to TM 3-4230-214-12&P (WP 0161) for M-13 Decontamination Unit PMCS.	
12	Monthly	M-8 Chemical Alarm	Refer to TM 3-6665-225-12 (WP 0161) for M-8 Chemical Alarm PMCS.	
13	Monthly	Radio	Refer to TM 11-5820-498-12 (WP 0161) for radio PMCS.	

END OF WORK PACKAGE

CHAPTER 5

MAINTENANCE
INSTRUCTIONS

OPERATOR MAINTENANCE LUBRICATION INSTRUCTIONS

INITIAL SETUP:

Not Applicable

WARNING



Adhesives, solvents, and sealing compounds can burn easily, can give off harmful vapors, and are harmful to skin and clothing. Keep away from open fire and use in well-ventilated area. If adhesive, solvent, or sealing compound gets on skin or clothing, wash immediately with soap and water. Failure to comply may result in injury or death to personnel.

NOTE

- The lowest level of maintenance authorized to lubricate a specific point is indicated by where that lubrication point falls within the PMCS tables. Operator/crew are only authorized to lubricate those points within the operator PMCS tables. Field level maintenance personnel are authorized to lubricate all points regardless of which tables (operator or field level) those lubrication points are listed.
- Refer to PMCS tables for specific lubrication points and localized views.
- Lubrication intervals are for normal operating conditions. Intervals may be shortened as required for severe operating conditions.
- Clean all lubrication points with cleaning compound, solvent and allow to dry prior to servicing.
- When using a grease gun, apply lubricant to the fitting until clean lubricant squeezes out of the part being lubricated.
- After a thorough high pressure washing, lubricate all grease fittings and oil can points outside and underneath vehicle.

- If vehicle fords water obstacle, service all lubrication points below fording depth and check submerged gearboxes for presence of water.
- Ensure equipment has correct lubricants appropriate to operating environment (expected continuous temperatures). If not, remove/drain and reapply/refill equipment with appropriate lubricants for operating environment as prescribed in these lubrication instructions.

Table 1. Engine Lubrication.

Item	Capacities	Expected Temperatures Above +15°F (-9°C)	Expected Temperatures +40 to -15°F (+4 to -26°C)	Expected Temperatures +40 to -50°F (+4 to -46°C)	Desert Conditions	Interval
Engine Oil (with filter change)	30 qt. (28.38 L)	OE/ HDO-15W/40 MIL-PRF-2104	OE/ HDO-15W/40 MIL-PRF-2104 or OEA MIL-PRF-46167 (Notes 1, 2, and 3)	OE/ HDO-15W/40 MIL-PRF-2104 or OEA MIL-PRF-46167 (Notes 1, 2, and 3)	OE/ HDO-40 MIL-PRF-2104	A-Annual (1 year)
Engine Oil (without filter change)	28 qt. (26.49 L)	OE/ HDO-15W/40 MIL-PRF-2104	OE/ HDO-15W/40 MIL-PRF-2104 or OEA MIL-PRF-46167 (Notes 1, 2, and 3)	OE/ HDO-15W/40 MIL-PRF-2104 or OEA MIL-PRF-46167 (Notes 1, 2, and 3)	OE/ HDO-40 MIL-PRF-2104	A-Annual (1 year)

Table 1. Engine Lubrication. - Continued

Item	Capacities	Expected Temperatures Above +15°F (-9°C)	Expected Temperatures +40 to -15°F (+4 to -26°C)	Expected Temperatures +40 to -50°F (+4 to -46°C)	Desert Conditions	Interval
<p>NOTE</p> <ol style="list-style-type: none"> 1. After changing to OEA, drain one pint (0.5 L) of oil from the oil sampling valve. 2. OEA must be used when temperatures are consistently below 0°F (-18°C). 3. OE/HDO-15W/40 must be used when temperatures are consistently above 0°F (-18°C). 						

Table 2. Transmission and Transfer Case Lubrication.

Item	Capacities	Expected Temperatures Above +15°F (-9°C)	Expected Temperatures +40 to -15°F (+4 to -26°C)	Expected Temperatures +40 to -50°F (+4 to -46°C)	Interval
Transmission Oil (with filter change)	38 qt. (36 L)	OE/HDO-15W/40 MIL-PRF-2104	OE/HDO-15W/40 MIL-PRF-2104 (Note 2)	OE/HDO-15W/40 MIL-PRF-2104 (Note 2)	A-Annual (1 year)
Transmission Oil (without filter change)	37 qt. (35 L)	OE/HDO-15W/40 MIL-PRF-2104	OE/HDO-15W/40 MIL-PRF-2104 (Note 2)	OE/HDO-15W/40 MIL-PRF-2104 (Note 2)	A-Annual (1 year)
Transfer Case	5 qt. (4.73 L)	OE/HDO-40	OE/HDO-40	OE/HDO-40	A-Annual (1 year)

Table 2. Transmission and Transfer Case Lubrication. - Continued

Item	Capacities	Expected Temperatures Above +15°F (-9°C)	Expected Temperatures +40 to -15°F (+4 to -26°C)	Expected Temperatures +40 to -50°F (+4 to -46°C)	Interval
		MIL-PRF-2104	MIL-PRF-2104 or OEA MIL-PRF-46167 (Notes 1 and 2)	MIL-PRF-2104 or OEA MIL-PRF-46167 (Notes 1 and 2)	
All Other Transmission and Transfer Case Lubrication Points	As Required	GAA MIL-PRF-10924	GAA MIL-PRF-10924 (Note 2)	GAA MIL-PRF-10924 (Note 2)	As Required (Note 3)

NOTE

1. OE/HDO-40 must be used when temperatures are consistently above 0°F (-18°C).
2. Refer to FM 9-207 (WP 0161) for arctic operation.
3. Refer to PMCS tables for specific lubrication intervals.

Table 3. Axle Lubrication.

Item	Capacities	Expected Temperatures Above +15°F (-9°C)	Expected Temperatures +40 to -15°F (+4 to -26°C)	Expected Temperatures +40 to -50°F (+4 to -46°C)	Interval
Axle 1	17.5 qt. (16.56 L)	GO-85W/140	GO-85W/140	GO-80W/90 MIL-PRF-2105	B-Biennial (2 Years)

Table 3. Axle Lubrication. - Continued

Item	Capacities	Expected Temperatures Above +15°F (-9°C)	Expected Temperatures +40 to -15°F (+4 to -26°C)	Expected Temperatures +40 to -50°F (+4 to -46°C)	Interval
		MIL-PRF-2105	MIL-PRF-2105 or GO-80W/90 MIL-PRF-2105 (Notes 1 and 3)	or GO-75 MIL-PRF-2105 (Notes 2 and 3)	(Note 4)
Axle 2 (and Power Divider)	21.5 qt. (20.34 L)	GO-85W/140 MIL-PRF-2105	GO-85W/140 MIL-PRF-2105 or GO-80W/90 MIL-PRF-2105 (Notes 1 and 3)	GO-80W/90 MIL-PRF-2105 or GO-75 MIL-PRF-2105 (Notes 2 and 3)	B-Biennial (2 Years) (Note 4)
Axle 3 (and Power Divider)	21 qt. (19.87 L)	GO-85W/140 MIL-PRF-2105	GO-85W/140 MIL-PRF-2105 or GO-80W/90 MIL-PRF-2105 (Notes 1 and 3)	GO-80W/90 MIL-PRF-2105 or GO-75 MIL-PRF-2105 (Notes 2 and 3)	B-Biennial (2 Years) (Note 4)
Axle 4	16.5 qt. (15.61 L)	GO-85W/140 MIL-PRF-2105	GO-85W/140 MIL-PRF-2105 or GO-80W/90	GO-80W/90 MIL-PRF-2105 or GO-75 MIL-PRF-2105	B-Biennial (2 Years) (Note 4)

Table 3. Axle Lubrication. - Continued

Item	Capacities	Expected Temperatures Above +15°F (-9°C)	Expected Temperatures +40 to -15°F (+4 to -26°C)	Expected Temperatures +40 to -50°F (+4 to -46°C)	Interval
			MIL-PRF-2105 (Notes 1 and 3)	(Notes 2 and 3)	
Oil Lubed Wheel Bearings	N/A	GO-85W/140 MIL-PRF-2105	GO-85W/140 MIL-PRF-2105 or GO-80W/90 MIL-PRF-2105 (Notes 1 and 3)	GO-80W/90 MIL-PRF-2105 or GO-75 MIL-PRF-2105 (Notes 2 and 3)	B-Biennial (2 Years)
All Other Axle Lubrication Points	As Required	GAA MIL-PRF-10924	GAA MIL-PRF-10924 (Note 3)	GAA MIL-PRF-10924 (Note 3)	As Required (Note 5)

NOTE

1. GO-85W/140 must be used when temperatures are consistently above 30°F (-1°C).
2. GO-85W/90 must be used when temperatures are consistently above -15°F (-26°C).
3. Refer to FM 9-207 (WP 0161) for arctic operation.
4. An initial lubrication change on new or rebuilt axles should occur between 500 mi. (805 km) and 1,000 miles (1 609 km). Refer to Field Level Annual PMCS for more information.
5. Refer to PMCS tables for specific lubrication intervals.

Table 4. Hydraulic Reservoir Servicing.

Item	Capacities	Expected Temperatures Above +15°F (-9°C)	Expected Temperatures +40 to -15°F (+4 to -26°C)	Expected Temperatures +40 to -50°F (+4 to -46°C)	Interval
Hydraulic Reservoir	120 qt. (113.52 L)	OE/HDO-10 MIL-PRF-2104 or OE/HDO-30 MIL-PRF-2104 (Note 1)	OE/HDO-10 MIL-PRF-2104 (Note 2)	OEA MIL-PRF-46167 (Notes 2 and 3)	A-Annual (1 year)
<p>NOTE</p> <ol style="list-style-type: none"> 1. OE/HDO-30 must be used only when temperatures are consistently above 60°F (16°C). 2. Refer to FM 9-207 (WP 0161) for arctic operation. 3. OEA must be used when temperatures are consistently below 0°F (-18°C). 					

Table 5. Radiator Servicing.

Item	Capacities	Expected Temperatures Above +15°F (-9°C)	Expected Temperatures +40 to -15°F (+4 to -26°C)	Expected Temperatures +40 to -50°F (+4 to -46°C)	Interval
Antifreeze (CID A-A-52624) (Note 1)	80 qt. (75.68 L)	80 qt. (75.68 L) 50% Ethylene Glycol Type IC (Recycled) (Notes 1 and 2)	80 qt. (75.68 L) 50% Ethylene Glycol Type IC (Recycled) (Notes 1 and 2)	80 qt. (75.68 L) 60% Ethylene Glycol Arctic Type IB (Recycled)	A-Annual (1 year) (Note 4)

Table 5. Radiator Servicing. - Continued

Item	Capacities	Expected Temperatures Above +15°F (-9°C)	Expected Temperatures +40 to -15°F (+4 to -26°C)	Expected Temperatures +40 to -50°F (+4 to -46°C)	Interval
				(Notes 1, 2, and 3)	
Antifreeze (CID A-A-52624) (Note 1)	80 qt. (75.68 L)	40 qt. (37.84 L) 100% Ethylene Glycol Type IA (Recycled) plus 40 qt. (37.84 L) water (Notes 1 and 5)	40 qt. (37.84 L) 100% Ethylene Glycol Type IA (Recycled) plus 40 qt. (37.84 L) water (Notes 1 and 5)	48 qt. (45.41 L) 100% Ethylene Glycol Type IA (Recycled) plus 32 qt. (30.27 L) water (Notes 1, 3, and 6)	A-Annual (1 year) (Note 4)
Antifreeze (CID A-A-52624) (Note 1)	80 qt. (75.68 L)	40 qt. (37.84 L) 100% Propylene Glycol Type IIA (virgin) plus 40 qt. (37.84 L) water (Notes 1 and 7)	40 qt. (37.84 L) 100% Propylene Glycol Type IIA (virgin) plus 40 qt. (37.84 L) water (Notes 1 and 7)	48 qt. (45.41 L) 100% Propylene Glycol Type IIA (virgin) plus 32 qt. (30.27 L) water (Notes 1, 3, and 8)	A-Annual (1 year) (Note 4)
Corrosion Inhibitor (Note 1)	2.4 qt. (2.27 L)	(Note 1)	(Note 1)	(Notes 1 and 3)	As Required

NOTE

1. Refer to TB 750-651 (WP 0161) for more information on antifreeze and additives used in the HEMTT series vehicle engine cooling

Table 5. Radiator Servicing. - Continued

Item	Capacities	Expected Temperatures Above +15°F (-9°C)	Expected Temperatures +40 to -15°F (+4 to -26°C)	Expected Temperatures +40 to -50°F (+4 to -46°C)	Interval
<p>system, and TM 750-254 (WP 0161) for detailed instructions for draining, cleaning, and flushing cooling systems of tactical vehicles.</p> <ol style="list-style-type: none"> 2. Type 1C (normal) and Type 1B (arctic) antifreeze is premixed, and DOES NOT REQUIRE the addition of water. Never add water or inhibitor to Type 1B antifreeze. 3. Refer to FM 9-207 (WP 0161) for arctic operation. 4. Engine coolant contaminant level is checked annually. Engine coolant does not need to be changed until it fails check. 5. A mixture of 50% Ethylene Glycol (EG) antifreeze to 50% water will provide freeze protection down to -34°F (-37°C). 6. A mixture of 50% Propylene Glycol (PG) antifreeze to 50% water will provide freeze protection down to -27°F (-33°C). 7. A mixture of 60% Ethylene Glycol (EG) antifreeze to 40% water will provide freeze protection down to -62°F (-52°C). 8. A mixture of 60% Propylene Glycol (PG) antifreeze to 40% water will provide freeze protection down to -56°F (-49°C). 					

Table 6. Self-Recovery Winch Lubrication.

Item	Capacities	Expected Temperatures Above +15°F (-9°C)	Expected Temperatures +40 to -15°F (+4 to -26°C)	Expected Temperatures +40 to -50°F (+4 to -46°C)	Interval
Self-Recovery Winch Gearbox (Note 1)	2 qt. (1.89 L)	GO-85W/140 MIL-PRF-2105	GO-75 MIL-PRF-2105 or GO-80W/90 MIL-PRF-2105 (Note 2)	GO-75 MIL-PRF-2105 (Note 2)	A-Annual (1 year)

Table 6. Self-Recovery Winch Lubrication. - Continued

Item	Capacities	Expected Temperatures Above +15°F (-9°C)	Expected Temperatures +40 to -15°F (+4 to -26°C)	Expected Temperatures +40 to -50°F (+4 to -46°C)	Interval
Winch Cable	As Required	OE/HDO-30 MIL-PRF-2104	OE/HDO-10 MIL-PRF-2104 (Note 1)	OEA MIL-PRF-46167 (Note 1)	S-Semiannual (WP 0149) (6 Months)
All Other Self-Recovery Winch Lubrication Points	As Required	GAA MIL-PRF-10924	GAA MIL-PRF-10924 (Note 2)	GAA MIL-PRF-10924 (Note 2)	As Required (Note 3)

NOTE

1. Pre-lubricated from manufacturer.
2. Refer to FM 9-207 (WP 0161) for arctic operation.
3. Refer to PMCS tables for specific lubrication intervals.

Table 7. Material Handling Crane Lubrication.

Item	Capacities	Expected Temperatures Above +15°F (-9°C)	Expected Temperatures +40 to -15°F (+4 to -26°C)	Expected Temperatures +40 to -50°F (+4 to -46°C)	Interval
Crane Swing Drive Gearbox	1 pt. (0.47 L)	GO-80W/90 MIL-PRF-2105	GO-80W/90 MIL-PRF-2105 (Note 1)	GO-75 MIL-PRF-2104 (Note 1)	A-Annual (1 year) (Note 2)
Crane Hoist	1 pt. (0.47 L)	GO-80W/90 MIL-PRF-2105	GO-80W/90 MIL-PRF-2105	GO-75 MIL-PRF-2104	A-Annual (1 year)

Table 7. Material Handling Crane Lubrication. - Continued

Item	Capacities	Expected Temperatures Above +15°F (-9°C)	Expected Temperatures +40 to -15°F (+4 to -26°C)	Expected Temperatures +40 to -50°F (+4 to -46°C)	Interval
			(Note 1)	(Note 1)	
Hoist Cable	As Required	OE/HDO-30 MIL-PRF-2104	OE/HDO-10 MIL-PRF-2104 (Note 1)	OEA MIL-PRF-46167 (Note 1)	S-Semiannual (WP 0149) (6 Months)
All Other Crane Lubrication Points	As Required	GAA MIL-PRF-10924	GAA MIL-PRF-10924 (Note 1)	GAA MIL-PRF-10924 (Note 1)	As Required (Note 3)
NOTE					
<ol style="list-style-type: none"> 1. Refer to FM 9-207 (WP 0161) for arctic operation. 2. Check level and add fluid as necessary. Currently there is no requirement to drain/fill crane swing drive gearbox. 3. Refer to PMCS tables for specific lubrication intervals. 					

Table 8. Oil Can Point Lubrication.

Capacities	Expected Temperatures Above +15°F (-9°C)	Expected Temperatures +40 to -15°F (+4 to -26°C)	Expected Temperatures +40 to -50°F (+4 to -46°C)	Intervals
As Required	OE/HDO-30 MIL-PRF-2104	OE/HDO-10 MIL-PRF-2104 (Note 1)	OEA MIL-PRF-46167 (Note 1)	As Required (Note 2)
NOTE				
<ol style="list-style-type: none"> 1. Refer to FM 9-207 (WP 0161) for arctic operation. 2. Refer to PMCS tables for specific oilcan lubrication intervals. 				

Table 9. Miscellaneous Lubrication Points.

Item	Capacities	Expected Temperatures Above +15°F (-9°C)	Expected Temperatures +40 to -15°F (+4 to -26°C)	Expected Temperatures +40 to -50°F (+4 to -46°C)	Interval
Brake Cam Slack Adjusters	As Required	GAA MIL-PRF-10924	GAA MIL-PRF-10924 (Note 1)	GAA MIL-PRF-10924 (Note 1)	S-Semiannual (WP 0149) (6 Months)
Cargo Body	As Required	GAA MIL-PRF-10924	GAA MIL-PRF-10924 (Note 1)	GAA MIL-PRF-10924 (Note 1)	S-Semiannual (WP 0149) (6 Months)
Pintle Hook	As Required	GAA MIL-PRF-10924	GAA MIL-PRF-10924 (Note 1)	GAA MIL-PRF-10924 (Note 1)	W-Weekly (WP 0148) S-Semiannual (WP 0149) (6 Months) (service fittings)
Propeller Driver Shafts and U-Joints	As Required	GAA MIL-PRF-10924	GAA MIL-PRF-10924 (Note 1)	GAA MIL-PRF-10924 (Note 1)	S-Semiannual (WP 0149) (6 Months) (Note 2)
Spare Tire Davit	As Required	GAA MIL-PRF-10924	GAA MIL-PRF-10924 (Note 1)	GAA MIL-PRF-10924 (Note 1)	S-Semiannual (WP 0149) (6 Months)
Spring Hanger Pins	As Required	GAA MIL-PRF-10924	GAA MIL-PRF-10924 (Note 1)	GAA MIL-PRF-10924 (Note 1)	S-Semiannual (WP 0149) (6 Months)

Table 9. Miscellaneous Lubrication Points. - Continued

Item	Capacities	Expected Temperatures Above +15°F (-9°C)	Expected Temperatures +40 to -15°F (+4 to -26°C)	Expected Temperatures +40 to -50°F (+4 to -46°C)	Interval
Steering System	As Required	GAA MIL-PRF-10924	GAA MIL-PRF-10924 (Note 1)	GAA MIL-PRF-10924 (Note 1)	S-Semiannual (WP 0149) (6 Months)

NOTE

1. Refer to FM 9-207 (WP 0161) for arctic operation.
2. When vehicle is operating under severe conditions, lubricate propeller shafts and universal joints every 50 hours of vehicle operation.
3. Refer to PMCS tables for specific lubrication intervals.

Table 10. Vehicle Cleaning.

Item	Capacities	Expected Temperature	Intervals
Cleaning Compound, Solvent (Note 1)	As Required	SD All Temperatures (Note 2)	As Required

NOTE

1. After a thorough high pressure washing, lubricate all grease fittings and oil can points outside and underneath vehicle.
2. Refer to FM 9-207 (WP 0161) for arctic operation.

END OF WORK PACKAGE

**OPERATOR MAINTENANCE
CLOSE/OPEN HEATER VALVES**

INITIAL SETUP:**Equipment Condition**

Engine OFF. (WP 0057)

Equipment Condition - Continued

Wheels chocked. (WP 0077)

Open passenger side engine cover.
(WP 0160)

CLOSE HEATER VALVES**NOTE**

- Closing two heater valves will improve efficiency of air conditioning kit.
- Closing two heater valves will disable cabin heat.
- Two heater valve knobs are located on front passenger side of engine, the bottom valve is located approximately 18 in. (46 cm) below the top valve.

1. Turn two heater valve knobs (1) counterclockwise to close.

CLOSE HEATER VALVES - Continued

Figure 1.

END OF TASK**OPEN HEATER VALVES****NOTE**

- Opening two heater valves will diminish efficiency of air conditioning kit.
- Opening two heater valves will enable cabin heat.
- Two heater valve knobs are located on front passenger side of engine, the bottom valve is located approximately 18 in. (46 cm) below the top valve.

1. Turn two heater valve knobs (1) clockwise to close.

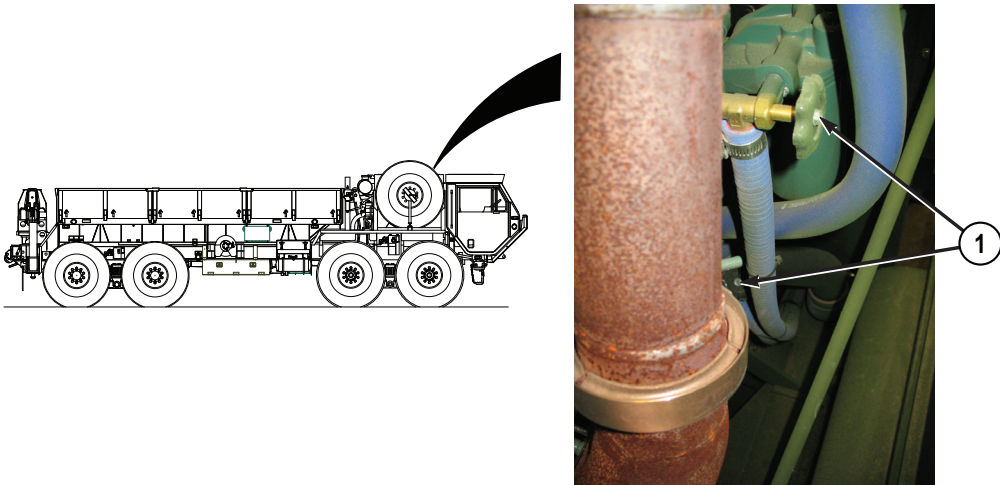
OPEN HEATER VALVES - Continued

Figure 2.

END OF TASK**FOLLOW-ON MAINTENANCE**

1. Close passenger side engine cover. (WP 0160)
2. Remove wheel chocks.

END OF WORK PACKAGE

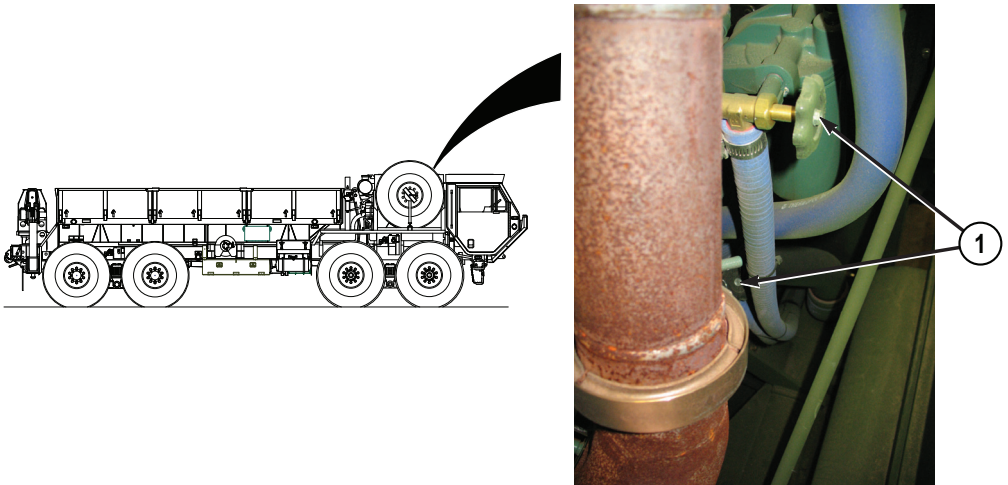
**OPERATOR MAINTENANCE
PRE/POST TOWING PROCEDURE (FRONT LIFT ONLY)**

INITIAL SETUP:**Tools and Special Tools**

Chain, 8 ft. (supplied by wrecker)
Chain, 7 ft. (supplied by wrecker)
(WP 0162, Table 3, Item 6)

Equipment Condition

Engine OFF. (WP 0057)

PREPARE VEHICLE FOR TOWING**CAUTION**

When installing axle restraint chains, route chains so hoses or lines are not between frame and chain or axle and chain. Failure to comply may result in damage to equipment.

NOTE

- This procedure is applicable to preparation for towing a HEMTT series vehicle from the front ONLY (refer to tow HEMTT-front lift for further information).
 - If disabled vehicle is either a BASE or A2 model HEMTT series vehicle (refer to data plate on inside of driver side door), complete Step (1).
 - If disabled vehicle is an A4 model HEMTT series vehicle (refer to data plate on inside of driver side door), skip to Step (2).
1. Perform the following on disabled vehicle:
 - a. Remove propeller shaft between transfer case and No. 3 axle.
 - b. Install axle restraint chains (1):

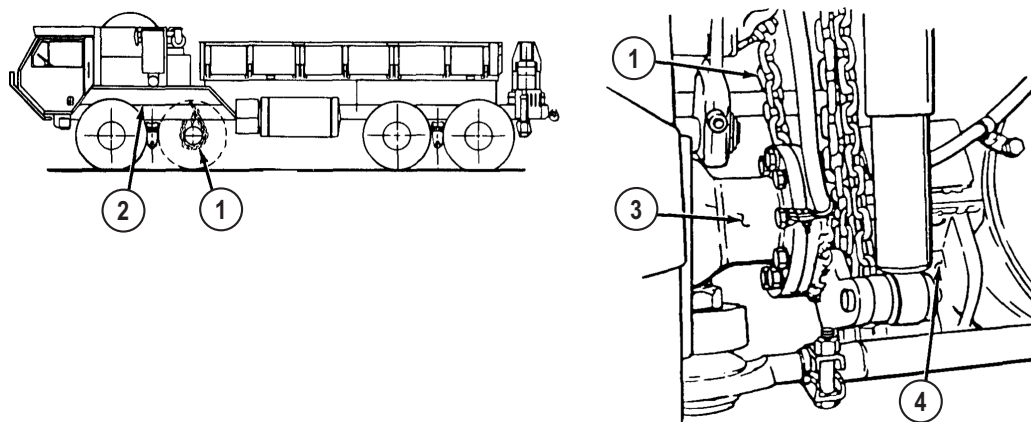
PREPARE VEHICLE FOR TOWING - Continued*Figure 1.***NOTE**

- Axle restraint chains are installed the same way, driver side shown.
- No. 2 axle should be restrained with chains on both sides of vehicle.

- (1) Route axle restraint chain (1) over frame rail (2) and around axle (3) beside walking beam (4).
- (2) Hook axle restraint chain (1) back into itself.
- (3) Repeat Steps (1) and (2) for opposite side of No. 2 axle (3).

CAUTION

When installing axle restraint chains, route chain around frame rail and axle only. Do not wrap chain around lateral torque rod, shock absorber, shift cables, etc. as they could be crushed. Route chains so hoses or lines are not between frame and chain or axle and chain. Failure to comply may result in damage to equipment.

NOTE

- This procedure is applicable to preparation for towing a HEMTT series vehicle from the front ONLY (refer to tow HEMTT-front lift for further information).
- If disabled vehicle is an A4 model HEMTT series vehicle (refer to data plate on inside of driver side door), complete Step (2).

PREPARE VEHICLE FOR TOWING - Continued

2. Perform the following on disabled vehicle:
 - a. Remove propeller shaft between transfer case and No. 3 axle.
 - b. Install axle restraint chains (1):

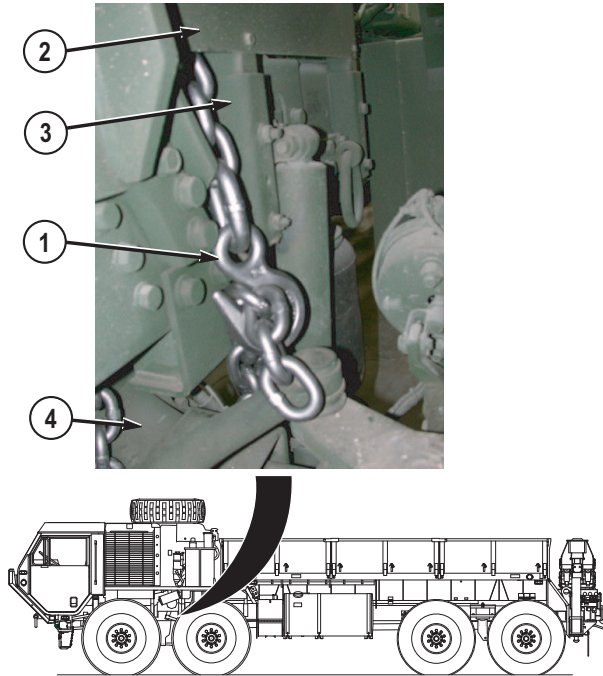
*Figure 2.***NOTE**

- Axle restraint chains are installed the same way, driver side shown.
- No. 2 axle should be restrained with chains on both sides of vehicle.

- (1) Route axle restraint chain (1) under engine shroud (2), over frame rail (3), and around axle (4).
- (2) Hook axle restraint chain (1) back into itself as shown.
- (3) Repeat Steps (1) and (2) for opposite side of No. 2 axle (3).

END OF TASK

POST TOWING PROCEDURE

NOTE

- This post towing procedure is applicable to a HEMTT series vehicle that has been towed from the front ONLY (refer to tow HEMTT-front lift for further information).
- If disabled vehicle is either a BASE or A2 model HEMTT series vehicle (refer to data plate on inside of driver side door), complete Step (1).
- If disabled vehicle is an A4 model HEMTT series vehicle (refer to data plate on inside of driver side door), skip to Step (2).

1. Perform the following to disabled vehicle:
 - a. Remove two axle restraint chains (1) from around frame rails (2) and No. 2 axle (3).

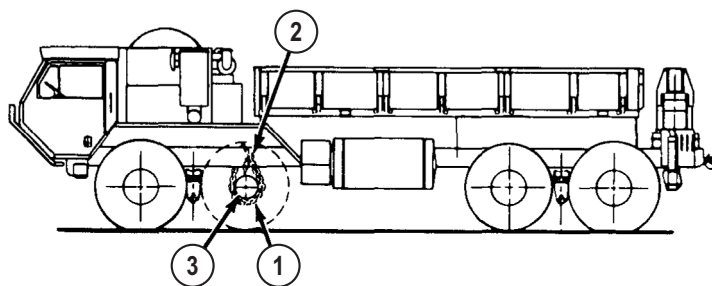

Figure 3.

- b. Return two axle restraint chains (1) to wrecker stowage.
- c. Install propeller shaft between transfer case and No. 3 axle.

NOTE

- This post towing procedure is applicable to a HEMTT series vehicle that has been towed from the front ONLY (refer to tow HEMTT-front lift for further information).
- If disabled vehicle is an A4 model HEMTT series vehicle (refer to data plate on inside of driver side door), complete Step (2).

2. Perform the following to disabled vehicle:
 - a. Remove two axle restraint chains (1) from under engine shroud (2), around frame rail (3), and No. 2 axle (4).

POST TOWING PROCEDURE - Continued

Figure 4.

- b. Return two axle restraint chains (1) to wrecker stowage.
- c. Install propeller shaft between transfer case and No. 3 axle.

END OF TASK

END OF WORK PACKAGE

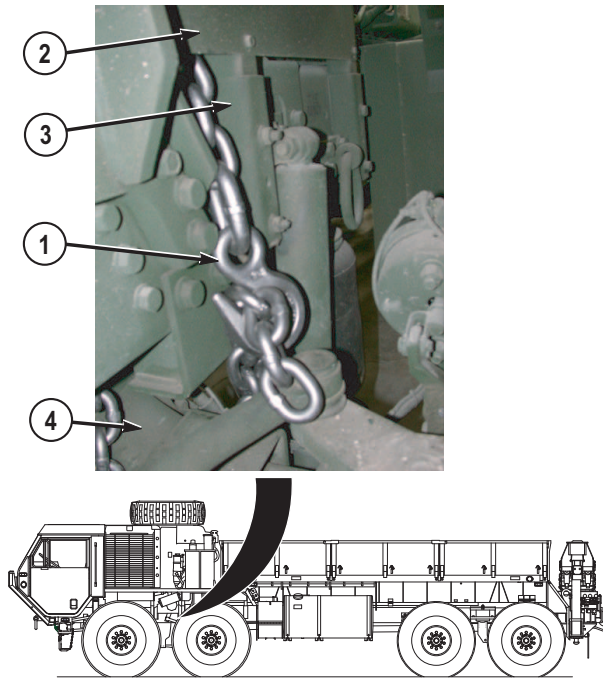
**OPERATOR MAINTENANCE
CLEAN VEHICLE**

INITIAL SETUP:**Materials/Parts**

Rag, Wiping (WP 0164, Table 1,
Item 50)

Equipment Condition

Engine OFF. (WP 0057)
Wheels chocked. (WP 0077)

CLEAN EXTERIOR**CAUTION**

Do not wipe dirt off vehicle when vehicle is dry. Dirt, stones, or debris may scratch and damage vehicle.

NOTE

After a thorough high pressure washing, lubricate all grease fittings and oil can points outside and underneath vehicle (refer to lubrication instructions (WP 0151) for more information).

1. Wash vehicle often with cool or warm water. Do not use strong detergent or abrasives.

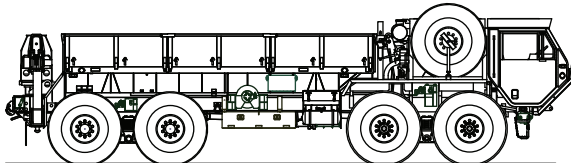

Figure 1.

2. While cleaning vehicle, look closely for rust, corrosion, bare metal, or other damage. Report any damage to Field Level Maintenance.

END OF TASK**CLEAN INTERIOR**

1. Remove loose dirt and dust from cab interior components (1).
2. Clean seat cushions (2) and seatbelts (3) with warm soapy water. Do not use abrasives or solvents.

CLEAN INTERIOR - Continued

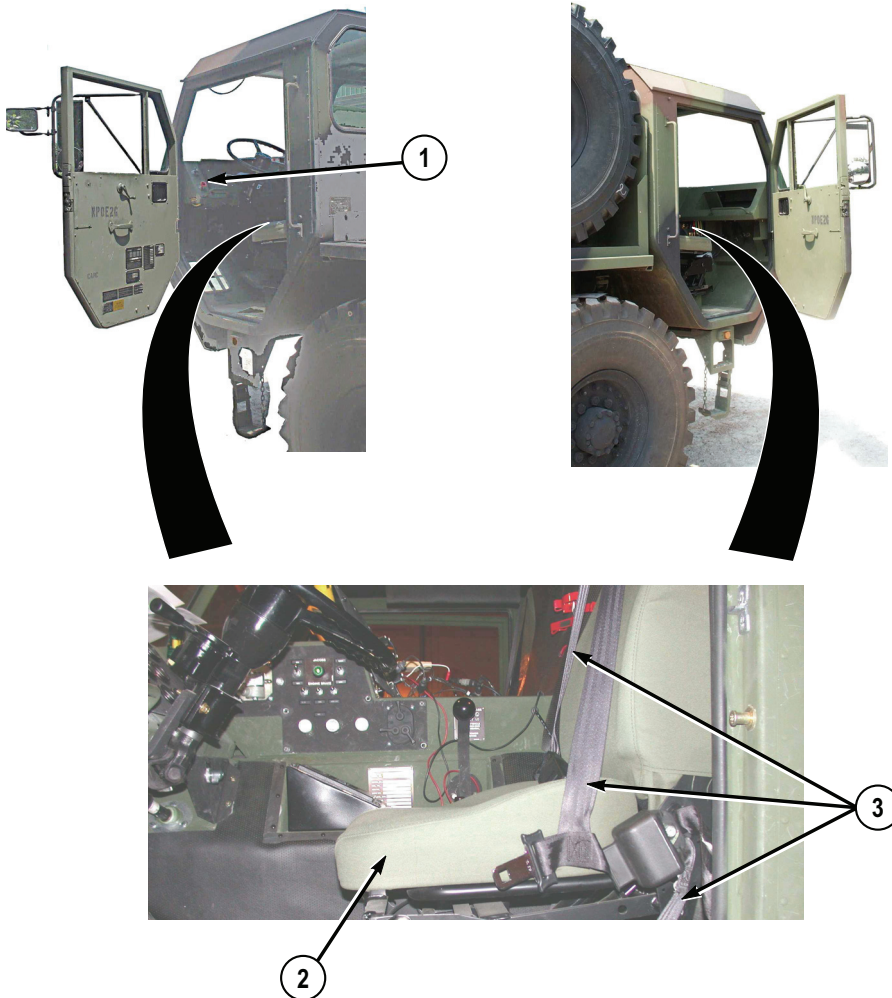

Figure 2.

3. Wipe seat cushions (2) and seatbelts (3) dry.

END OF TASK

END OF WORK PACKAGE

OPERATOR MAINTENANCE CHANGE WHEEL AND TIRE ASSEMBLY

INITIAL SETUP:

Tools and Special Tools

Chocks, Wheel (2) (WP 0162, Table 3, Item 8)
Extension, Handle (WP 0162, Table 3, Item 12)
Handle, Wrench (WP 0162, Table 3, Item 13)
Jack, 12-ton, With Handle (WP 0162, Table 3, Item 16)
Jack, Base Plate (WP 0162, Table 3, Item 19)

Tools and Special Tools - Continued

Warning Device Set, Triangular (WP 0162, Table 3, Item 21)
Wrench, Wheel Lugnut (WP 0162, Table 3, Item 32)
Wrench, Adjustable (WP 0162, Table 3, Item 30)

Personnel Required

Operator and Assistant - - - (2)

PREPARE VEHICLE

1. Shut off engine. (WP 0057)

WARNING



Park vehicle in safe area, out of traffic, where there is no danger to personnel changing tire assembly. Park vehicle on hard level ground. Failure to comply may result in injury or death to personnel.

2. Turn on emergency flashers. (WP 0076)
3. Set up emergency marker kit, as necessary. (WP 0100)

END OF TASK

SET UP TIRE DAVIT WINCH

1. Remove hoist arm (1) from mounting bracket (2).

SET UP TIRE DAVIT WINCH - Continued

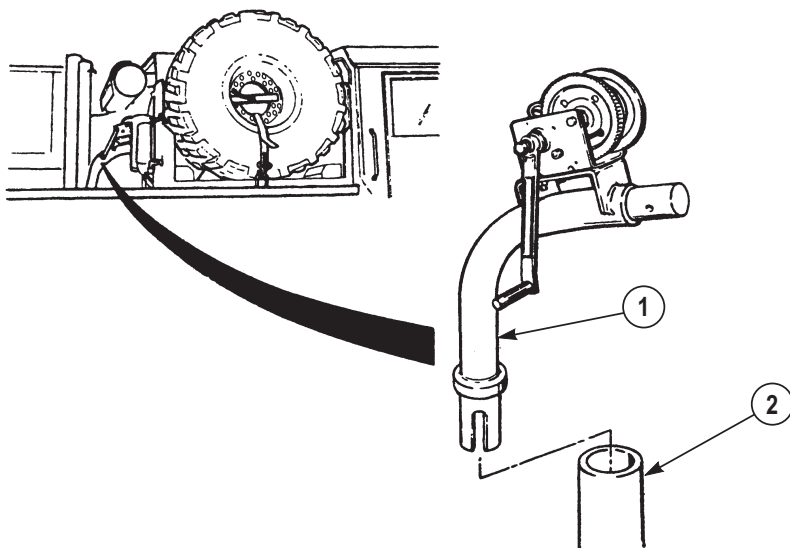
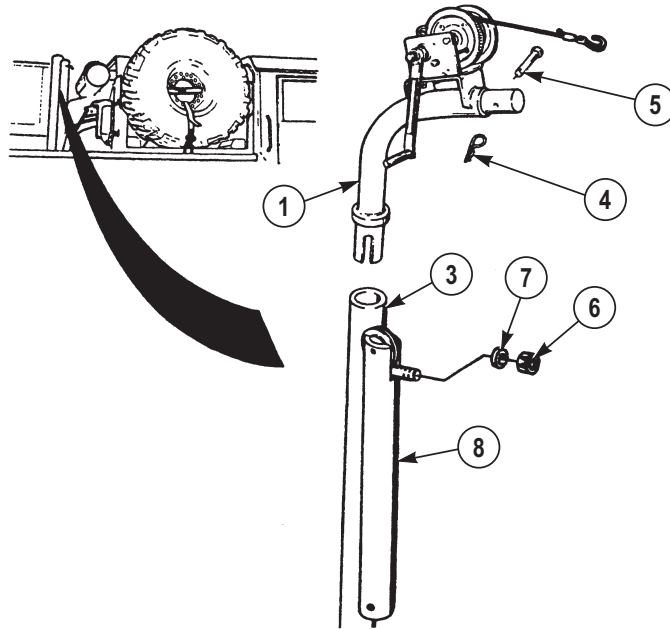

Figure 1.

2. Install hoist arm (1) in mount (3).

SET UP TIRE DAVIT WINCH - Continued

*Figure 2.*

3. Remove and keep safety pin (4) and pin (5) from hoist arm (1).
4. Remove nut (6), washer, and extension (8) from mount (3).
5. Install extension (8) in hoist arm (1).

SET UP TIRE DAVIT WINCH - Continued

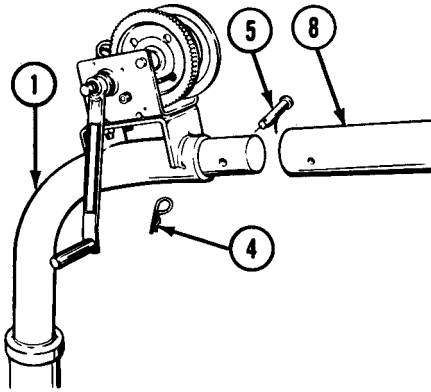
*Figure 3.*

6. Line up holes in extension (8) and hoist arm (1).
7. Install pin (5) and safety pin (4).
8. Turn hand crank (9) CCW and route cable (10) over end of pulley (11).

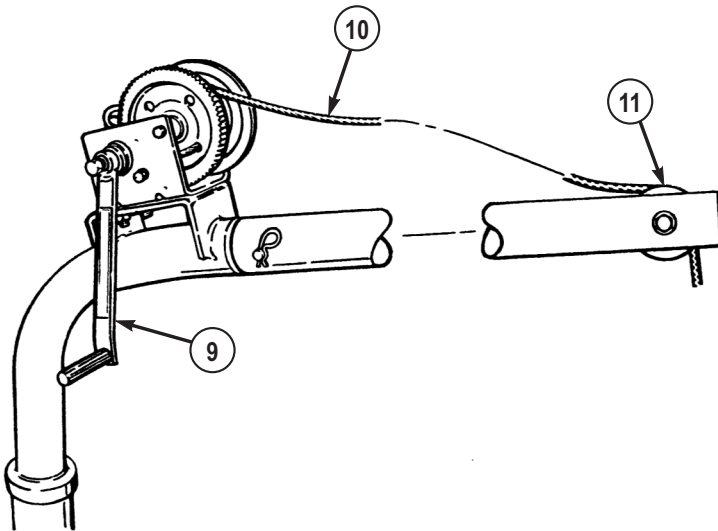
*Figure 4.***END OF TASK**

REMOVE SPARE WHEEL AND TIRE ASSEMBLY

1. Remove two wheel chocks (1) from under spare wheel and tire assembly (2).

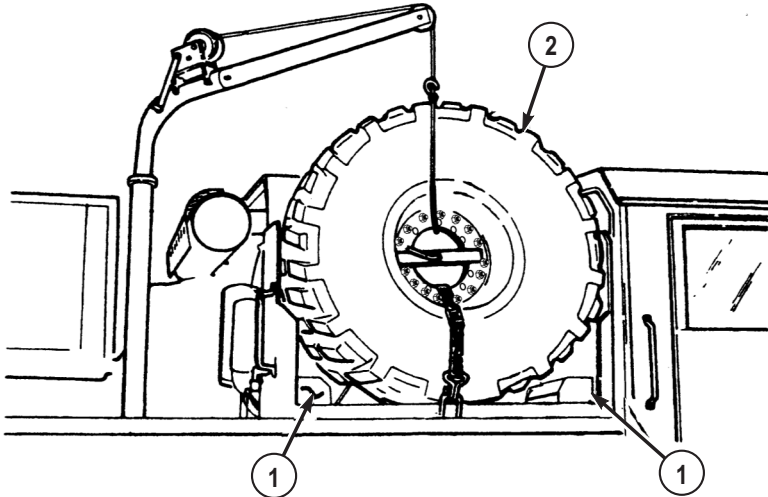

Figure 5.

2. Install two wheel chocks (WP 0077) (1) on wheel and tire assembly (3) that is across from flat wheel and tire assembly (4).

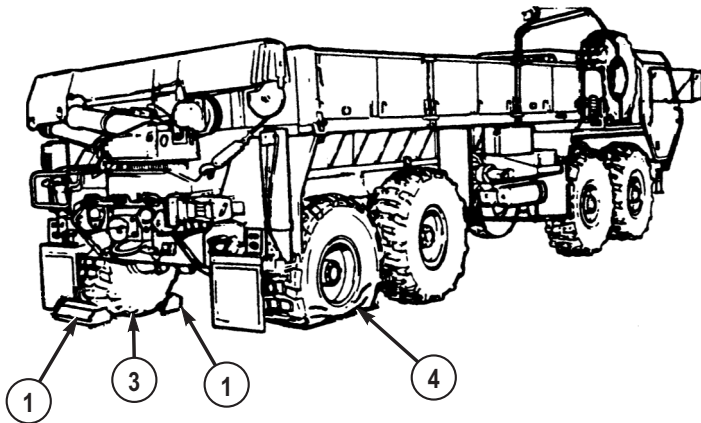
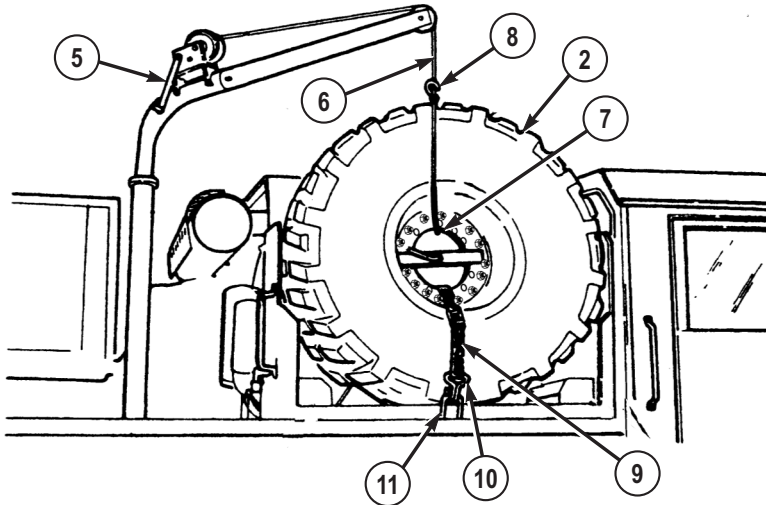
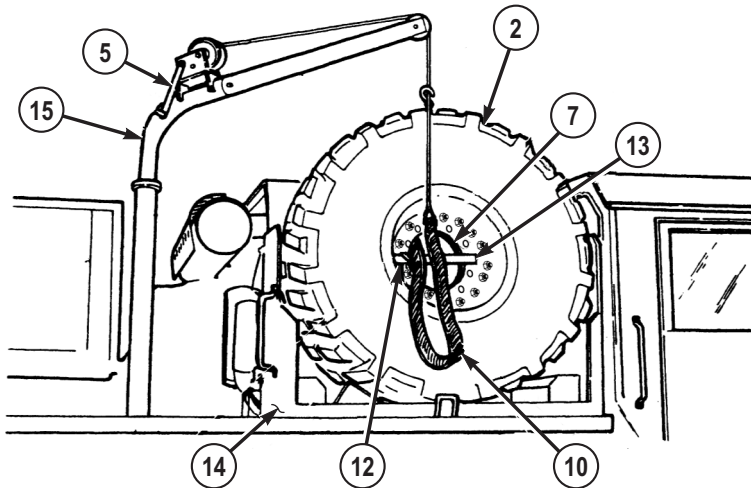

Figure 6.

3. Turn hand crank (5) counterclockwise to let out enough cable (6) to push through hole in wheel (7) and wrap around spare wheel and tire assembly (2).

REMOVE SPARE WHEEL AND TIRE ASSEMBLY - Continued*Figure 7.*

4. Wrap cable (6) through hole in wheel (7) and around spare wheel and tire assembly (2), and secure with hook (8).
5. Turn hand crank (5) clockwise to put light tension on cable (6).
6. Release clamp (9), and disconnect tiedown strap (10) from bracket (11) on both sides of spare wheel and tire assembly (2).
7. Hook tiedown strap (10) on hole in wheel (7) on both sides of spare wheel and tire assembly (2).

REMOVE SPARE WHEEL AND TIRE ASSEMBLY - Continued*Figure 8.*

8. Turn lever (12) counterclockwise.
9. Remove lever (12) and holddown plate (13). Set aside lever (12) and holddown plate (13) for later use.

NOTE

Stand on passenger side front fender to operate tire davit winch while other assistant stands on ground near second axle to guide wheel and tire assembly down.

10. Turn hand crank (5) clockwise to lift spare wheel and tire assembly (2) just above carrier (14).
11. Swing hoist arm (15) so spare wheel and tire assembly (2) is clear of vehicle, while assistant pulls on tiedown strap (10) to guide spare wheel and tire assembly out of carrier (14).
12. Turn hand crank (5) counterclockwise to lower spare wheel and tire assembly (2) to ground, while assistant holds spare wheel and tire assembly (2) steady with tiedown strap (10).
13. Remove tiedown strap (10).
14. Push spare wheel and tire assembly (2) against vehicle.

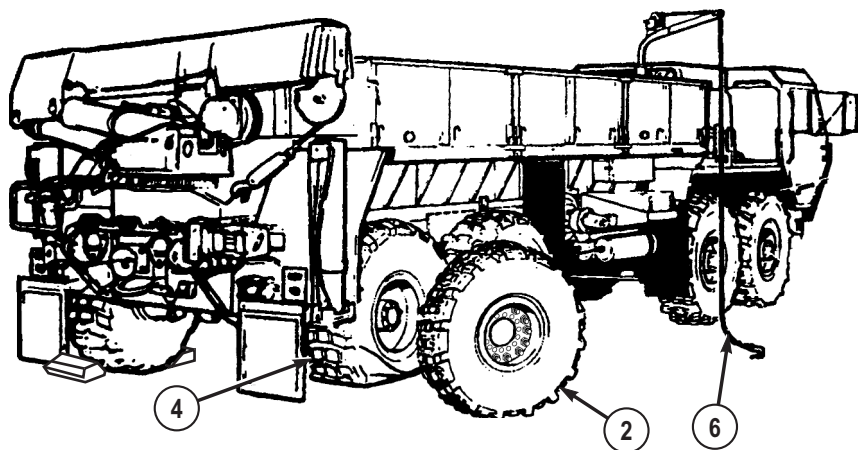
REMOVE SPARE WHEEL AND TIRE ASSEMBLY - Continued*Figure 9.*

15. Remove cable (6) from spare wheel and tire assembly (2), and roll spare wheel and tire assembly (2) next to axle of flat wheel and tire assembly (4).
16. Check spare wheel and tire assembly (2) air pressure and service as required. (WP 0158)

END OF TASK**REMOVE WHEEL AND TIRE ASSEMBLY**

1. Remove jack (1) and jack base plate (2) from stowage.

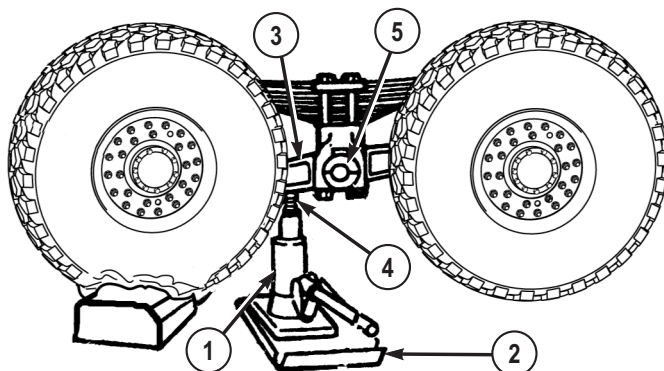
*Figure 10.*

REMOVE WHEEL AND TIRE ASSEMBLY - Continued**NOTE**

It may be necessary to place wheel chock under flat wheel and tire assembly to get jack and jack base plate under equalizing beam.

2. Position jack (1) and jack base plate (2) under equalizing beam (3).
3. Unscrew jack ram (4) until it touches equalizing beam (3) approximately 4 to 5 in. (102 to 127 mm) from beam center pivot point (5).

NOTE

Studs and lugnuts on driver side of vehicle have left-hand threads. Rotate lugnuts clockwise to loosen, counterclockwise to tighten. Studs and lugnuts on passenger side of vehicle have right-hand threads. Rotate lugnuts counterclockwise to loosen, clockwise to tighten.

4. Loosen 10 lugnuts (6) until they turn easily.

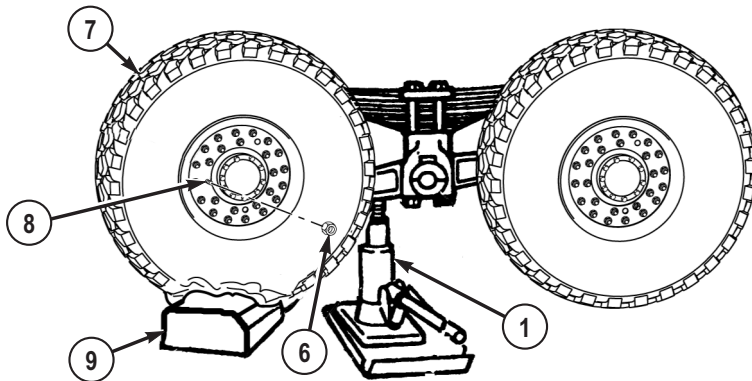

Figure 11.

NOTE

If chock was used to help position jack, wheel and tire assembly does not have to be clear of chock.

5. Raise jack (1) until flat wheel and tire assembly (7) can be removed.
6. Remove 10 lugnuts (6) from studs (8) and set lugnuts (6) aside.

NOTE

If wheel chock was not used to position jack, skip to Step (8).

7. Remove wheel chock (9) and return it to vehicle stowage.

REMOVE WHEEL AND TIRE ASSEMBLY - Continued

8. Using jack (1), lower vehicle until flat wheel and tire assembly (7) is just touching ground.
9. Tilt top of flat wheel and tire assembly (7) forward, while assistant raises jack (1) slightly. Wheel and tire assembly (7) should move forward.
10. Repeat Steps (8) and (9) to walk flat wheel and tire assembly (7) off studs (8).
11. Remove flat wheel and tire assembly (7) and lean flat wheel and tire assembly against vehicle.

END OF TASK**INSTALL WHEEL AND TIRE ASSEMBLY****NOTE**

Tire tread is non-directional. Vehicle operation is not affected by direction of traction bars.

1. With aid of an assistant, roll wheel and tire assembly (1) up to axle (2).

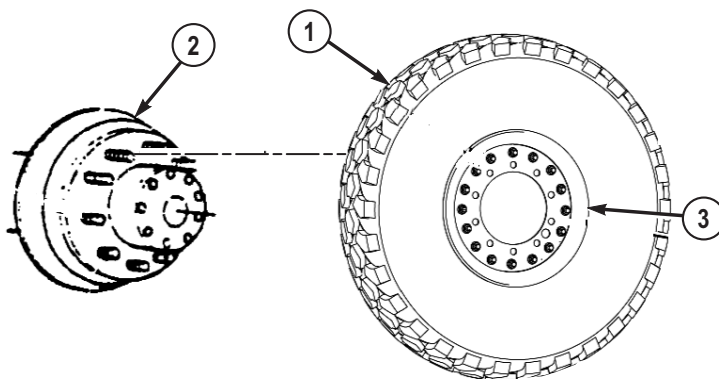

Figure 12.

NOTE

Check that spare wheel and tire assembly wheel dish is in same position as flat wheel and tire assembly wheel dish. Deep side of wheel dish will face toward vehicle on four front wheels. Deep side of wheel dish will face away from vehicle on four rear wheels except M984A. All eight wheels on M984A are installed with deep side of wheel dish facing toward vehicle.

INSTALL WHEEL AND TIRE ASSEMBLY - Continued

2. Make sure deep side of spare wheel and tire assembly wheel dish (3) is in same position as flat/shredded wheel and tire assembly wheel dish when flat/shredded wheel and tire assembly was removed.

NOTE

- Tire valve stem extension must be removed to reposition wheel and tire assembly valve stem extension.
 - It may be necessary to reposition valve stem to accomplish installation of valve stem extension.
3. Make sure wheel and tire assembly valve stem (4) is pointing out, away from vehicle.

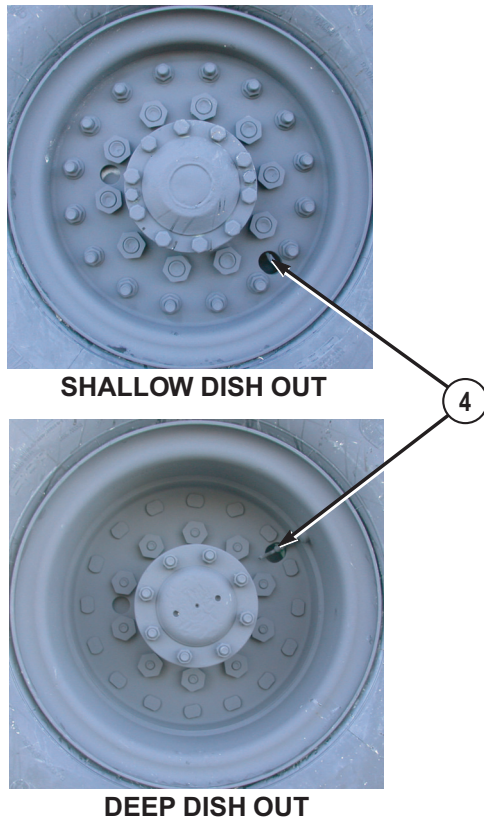
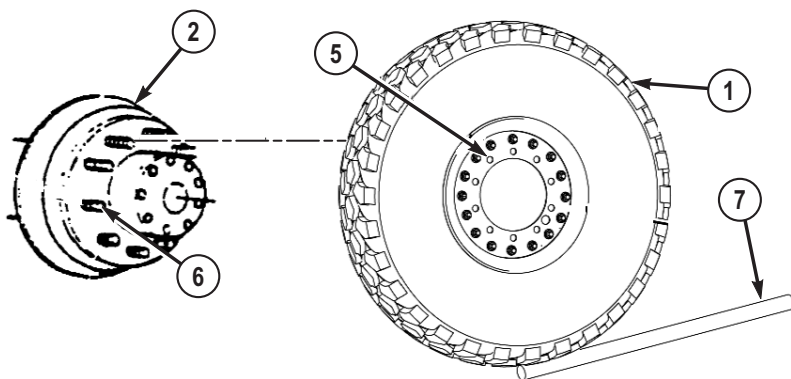

Figure 13.

4. Line up holes in rim (5) of wheel and tire assembly (1) with studs (6) on axle (2).

INSTALL WHEEL AND TIRE ASSEMBLY - Continued*Figure 14.***WARNING**

Wheel/tire assembly weighs 540 lbs (245 kg). Do not attempt to lift or move wheel/tire assembly without the aid of an assistant and a lifting device. Failure to comply may result in injury or death to personnel.

5. Lean top of wheel and tire assembly (1) against studs (6) and axle (2).

NOTE

Install a lugnut on top stud, and hand-tighten to hold wheel and tire assembly in place.

6. Using handle extension (7), slide spare wheel and tire assembly onto studs (6) while assistant raises vehicle with jack. Bottom of wheel and tire assembly (1) should swing toward axle (2).
7. Assistant lowers vehicle until wheel and tire assembly (1) just touches ground.
8. Repeat Steps (5) through (7) until wheel and tire assembly (1) is seated on axle (2) and studs (6).

NOTE

- Studs and lugnuts on driver side of vehicle have left-hand threads. Rotate lugnuts counterclockwise to tighten.

INSTALL WHEEL AND TIRE ASSEMBLY - Continued

- Studs and lugnuts on passenger side of vehicle have right-hand threads. Rotate lugnuts clockwise to tighten.

9. Install and tighten 10 lugnuts (8) in order shown using wheel lugnut wrench.

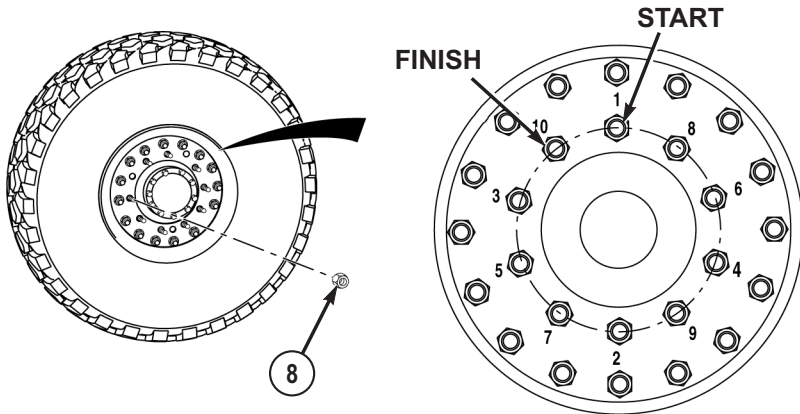

Figure 15.

10. Assistant lowers jack (9) until vehicle weight is fully supported by suspension system.
11. Remove jack (9) and jack base plate (10) from under vehicle.

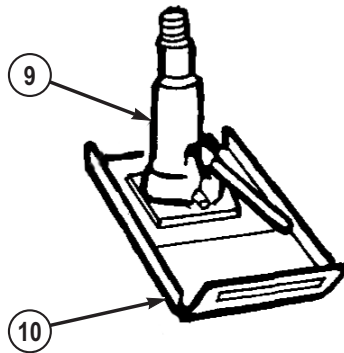
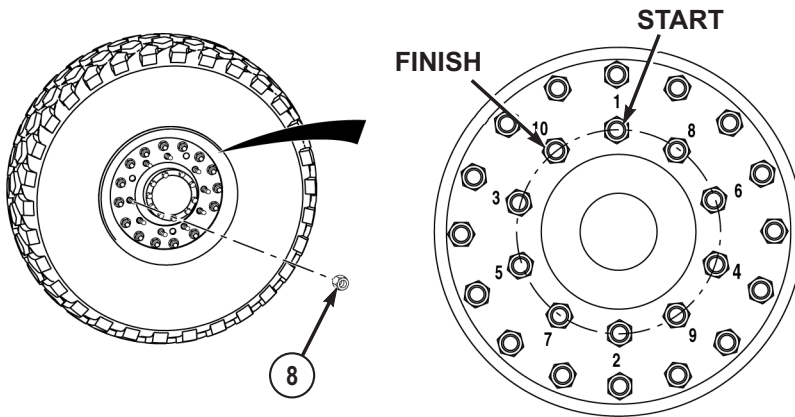

Figure 16.

12. Tighten 10 lugnuts (8) in order shown until they no longer tighten.

INSTALL WHEEL AND TIRE ASSEMBLY - Continued*Figure 17.*

13. Return all tools and equipment to proper storage boxes.
14. Return vehicle to field level maintenance and have lugnuts (8) tightened to torque requirements as soon as possible.

END OF TASK**STOW FLAT WHEEL AND TIRE ASSEMBLY**

1. Roll flat wheel and tire assembly (1) under hoist arm (2) so deep side of wheel dish (3) is facing out and away from vehicle.

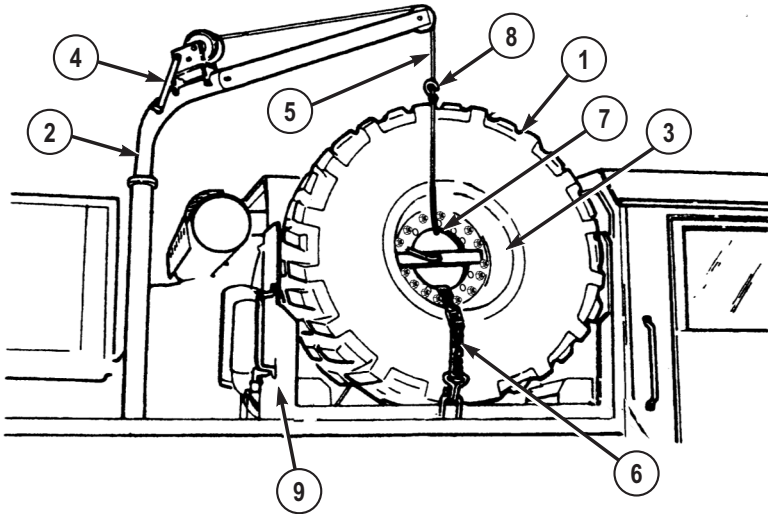
STOW FLAT WHEEL AND TIRE ASSEMBLY - Continued*Figure 18.***NOTE**

Assistant stands on passenger side front fender to operate tire davit winch while other assistant stands on ground near second axle to guide wheel and tire assembly into carrier.

2. Turn hand crank (4) counterclockwise to let out cable (5).
3. Pull tiedown strap (6) through hole in wheel (7), and hook ends to hole on both sides of wheel.
4. Hook ends of tiedown strap (6) to both sides of hole in wheel (7).
5. Pull cable (5) through hole in wheel (7) and secure hook (8) back into cable as shown.

WARNING

Inner wheel weighs 105 lbs (48 kg). Do not attempt to lift or move inner wheel without the aid of an assistant and a lifting device. Failure to comply may result in injury or death to personnel.

STOW FLAT WHEEL AND TIRE ASSEMBLY - Continued

6. Turn hand crank (4) clockwise to raise flat wheel and tire assembly (1) just above carrier (9) while assistant holds tiedown strap (6) to steady wheel and tire assembly (1).
7. Swing hoist arm (2) so flat wheel and tire assembly (1) is over carrier (9) while assistant guides wheel and tire assembly with tiedown strap (6).
8. Turn hand crank (4) counterclockwise to lower flat wheel and tire assembly (1) into carrier (9).
9. Remove tiedown strap (6).
10. Hold flat wheel and tire assembly (1) steady, while assistant installs holddown plate (10).

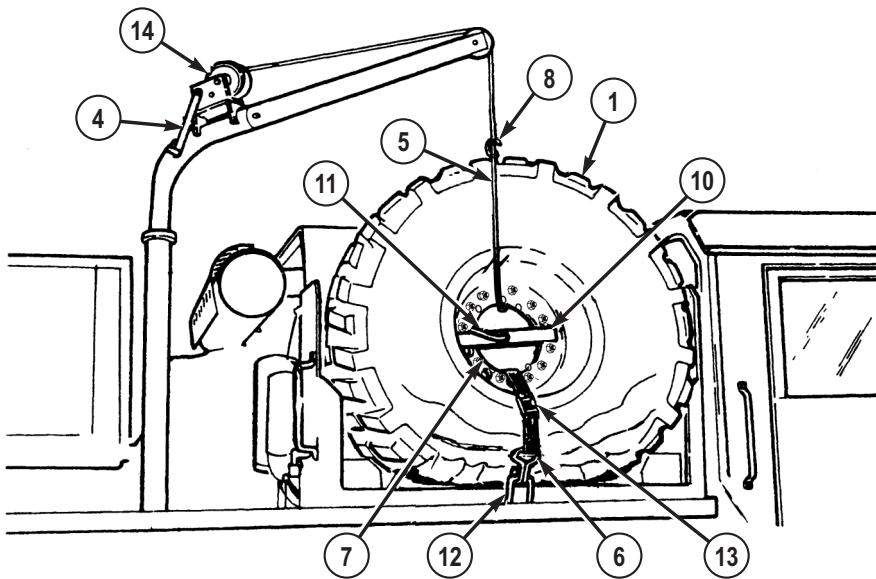

Figure 19.

11. Install lever (11) and turn clockwise to tighten.
12. Slide tiedown strap (6) through hole in wheel (7).
13. Connect tiedown strap (6) to outside holddown bracket (12), while assistant connects tiedown strap to inside holddown bracket.
14. Pull latch (13) down and lock to secure flat wheel and tire assembly (1).
15. Turn hand crank (4) counterclockwise to loosen cable (5).
16. Remove hook (8) and cable (5) from wheel and tire assembly (1).

STOW FLAT WHEEL AND TIRE ASSEMBLY - Continued

17. Turn hand crank (4) clockwise and wind cable (5) fully onto reel (14).

END OF TASK**STOW TIRE DAVIT WINCH**

1. Remove safety pin (1) and pin (2) from extension (3).

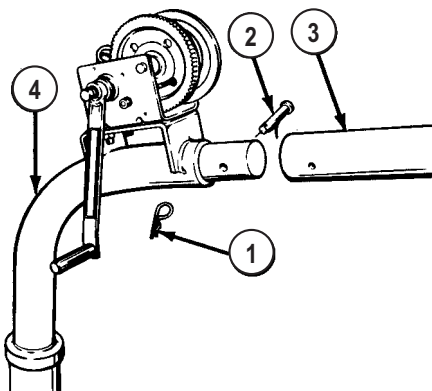
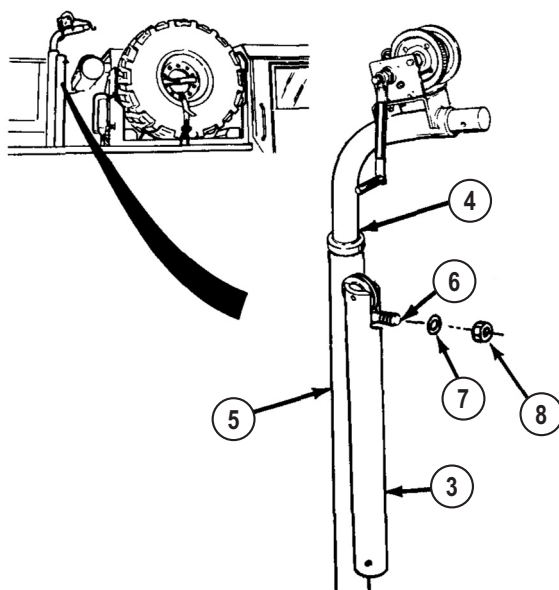

Figure 20.

2. Pull extension (3) from hoist arm (4).
3. Install extension (3) on mount (5).

STOW TIRE DAVIT WINCH - Continued

*Figure 21.*

4. Slide top of extension (3) over stud (6).
5. Secure extension (3) with washer (7) and nut (8).
6. Pull hoist arm (4) from mount (5).
7. Put hoist arm (4) into mounting bracket (9).

STOW TIRE DAVIT WINCH - Continued

Figure 22.

8. Install pin (10) through hoist arm (4).
9. Secure pin (10) with safety pin (11).
10. Pick up and stow emergency marker kit (as necessary).

END OF TASK

END OF WORK PACKAGE

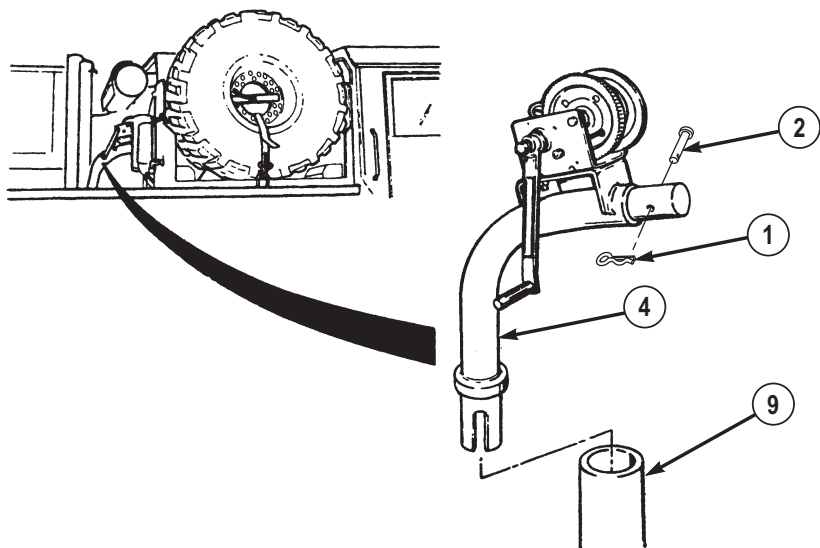
OPERATOR MAINTENANCE CLEAN FUEL TANK STRAINER

INITIAL SETUP:

Materials/Parts

Rag, Wiping (WP 0164, Table 1,
Item 50)

Equipment Condition

Engine OFF. (WP 0057)
Wheels chocked. (WP 0077)

REMOVE/CLEAN FUEL TANK STRAINER

WARNING



Fuel is very flammable and can explode easily. Keep fuel away from open fire and keep fire extinguisher within easy reach when working with fuel. Do not work on fuel system when engine is hot. Fuel can be ignited when engine is hot. When working with fuel, post signs that read NO SMOKING WITHIN 50 FEET OF VEHICLE. Failure to comply may result in injury or death to personnel.

1. Wipe off dirt from fuel filler cap (1).

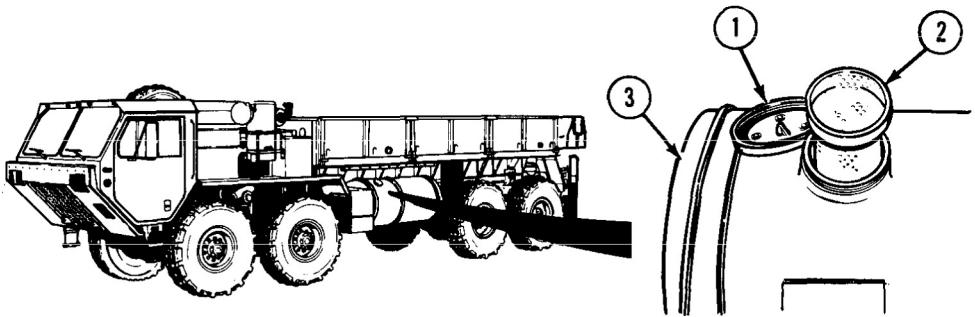

Figure 1.

2. Remove fuel filler cap (1).
3. Pull strainer (2) out of fuel tank (3).

REMOVE/CLEAN FUEL TANK STRAINER - Continued

4. Clean strainer (2) with clean dry rag.

END OF TASK**INSTALL FUEL TANK STRAINER**

1. Put strainer (2) in fuel tank (3).

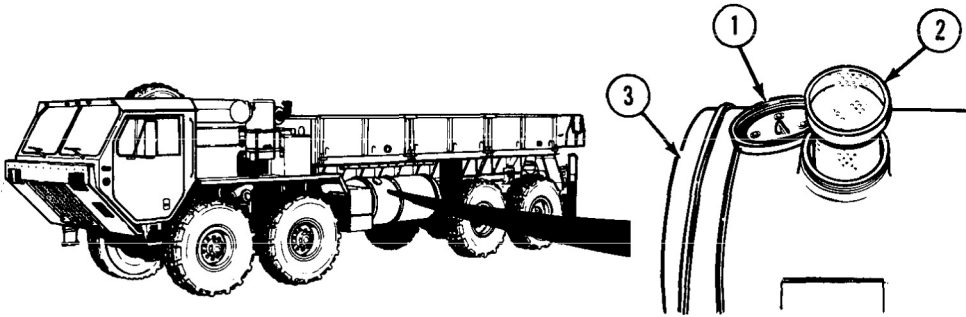

Figure 2.

2. Install and tighten fuel filler cap (1).

END OF TASK**FOLLOW-ON MAINTENANCE**

1. Remove wheel chocks.

END OF WORK PACKAGE

OPERATOR MAINTENANCE SERVICE AIR CLEANER ELEMENT

INITIAL SETUP:

Tools and Special Tools

Ladder (WP 0162, Table 2, Item 2)

Equipment Condition

Engine OFF. (WP 0057)

Wheels chocked. (WP 0077)

Materials/Parts

Rag, Wiping (WP 0164, Table 1, Item 50)

REMOVE AIR CLEANER ELEMENT

1. Lift up three levers (1).

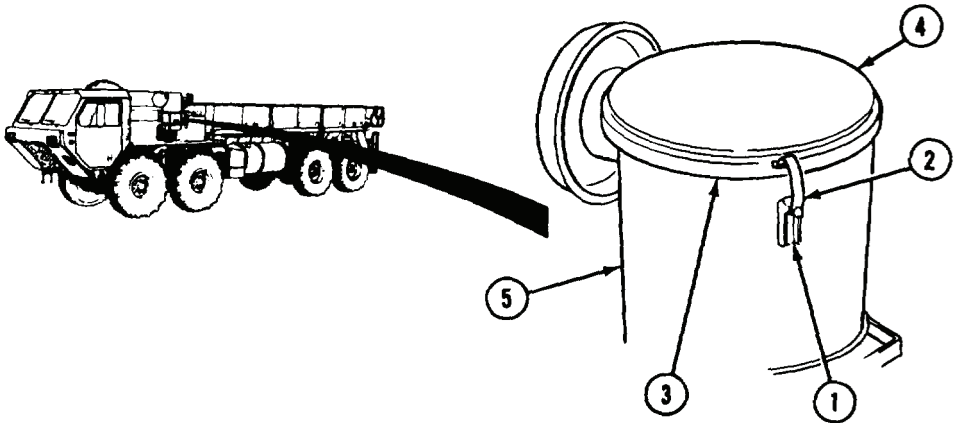
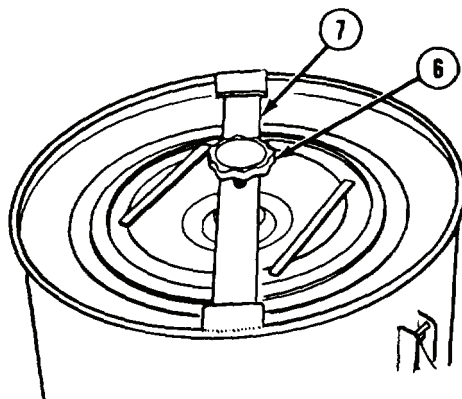

Figure 1.

2. Unhook three latches (2) from cover groove (3).
3. Remove cover (4) from canister (5).
4. Unscrew knob (6) until retaining bar (7) is loose.

REMOVE AIR CLEANER ELEMENT - Continued*Figure 2.*

5. Remove knob (6) and retaining bar (7).

CAUTION

Do not remove secondary filter element. Dirt and debris can fall into canister and cause damage to engine.

6. Take hold of handles (8) and remove primary element (9) from canister (5).

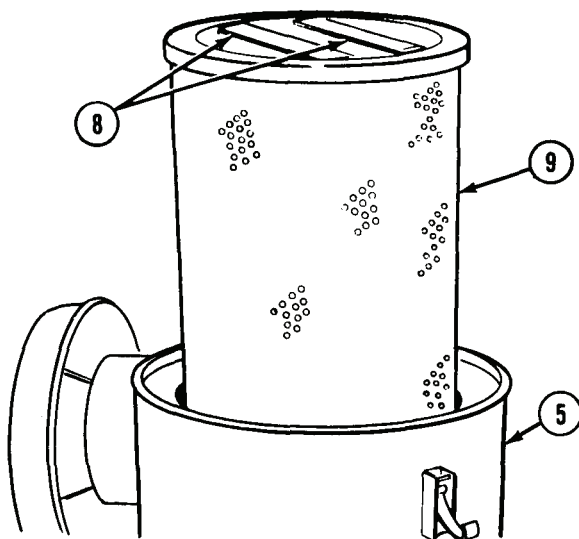
REMOVE AIR CLEANER ELEMENT - Continued*Figure 3.***END OF TASK****CLEAN AIR CLEANER ELEMENT****NOTE**

Notify field level maintenance if primary filter element is damaged or cannot be cleaned by tapping.

1. Tap side of primary element (9) lightly against hand.

CLEAN AIR CLEANER ELEMENT - Continued

Figure 4.

2. Dump out dirt and dust from primary element (9).
3. Wipe primary element (9) with clean rag.

END OF TASK**INSTALL AIR CLEANER ELEMENT**

1. Install primary element (9) in air cleaner canister (5).

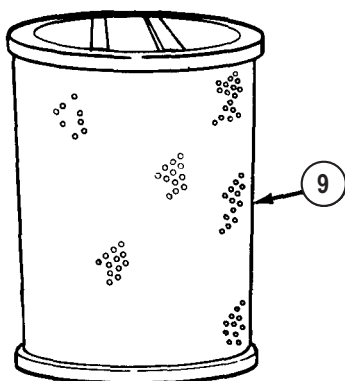
INSTALL AIR CLEANER ELEMENT - Continued

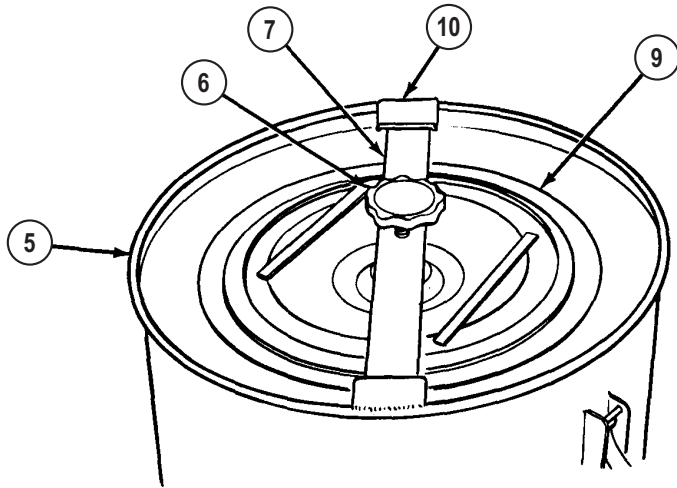

Figure 5.

2. Position knob (6) and retaining bar (7) over primary element (9). Make sure ends of retaining bar are in tabs (10).
3. Tighten knob (6) to secure primary element (9).
4. Put cover (4) on top of air cleaner canister (5).

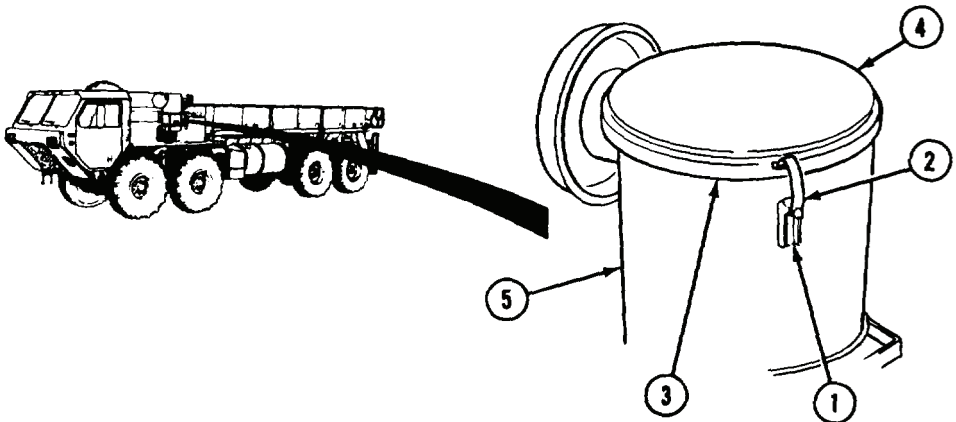

Figure 6.

INSTALL AIR CLEANER ELEMENT - Continued

5. Put three latches (2) in cover groove (3).
6. Push three levers (1) down to secure cover (4).
7. Start engine. (WP 0044)
8. Push button (11) to reset air cleaner restriction indicator (12). If indicator window (13) shows VACUUM INCHES H2O below 20, continue with vehicle operation but notify Field Level Maintenance as soon as possible. If indicator window shows VACUUM INCHES H2O above 20, notify Field Level Maintenance.

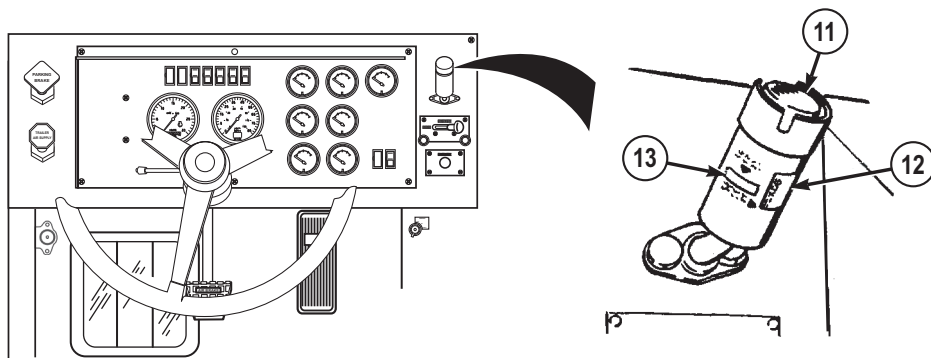

Figure 7.

9. Shut OFF engine. (WP 0057)

END OF TASK**FOLLOW-ON MAINTENANCE**

1. Remove wheel chocks.

END OF WORK PACKAGE

OPERATOR MAINTENANCE SERVICE TIRES

INITIAL SETUP:

Tools and Special Tools

Gauge, Tire Pressure (WP 0162,
Table 3, Item 11)

Tools and Special Tools - Continued

Gauge, Tire Pressure (WP 0162,
Table 3, Item 15)
Hose: Air, Pneumatic (WP 0162,
Table 3, Item 14)

Equipment Condition

Engine OFF. (WP 0057)
Wheels chocked. (WP 0077)

CHECK TIRE PRESSURE

WARNING



Failure to comply with these procedures may result in faulty positioning of the tire and/or rim parts and cause the assembly to burst with explosive force. Never mount or use damaged tires or rims. Failure to comply may result in injury or death to personnel.

NOTE

There are two types of air pressure gauges. One is a separate handheld gauge. The other is a combined pressure gauge/inflation hose.

Both may be used to check air pressure in tire.

ALWAYS use combined pressure gauge/inflation hose to inflate tire.

1. Check tire air pressure with tire pressure gauge.
2. Ensure tires have correct air pressure for road conditions and driving speed .

END OF TASK

INFLATE TIRE

1. Remove air hose (1) from stowage and connect air hose (1) to quick disconnect coupling (2) by pushing back sleeve (3).

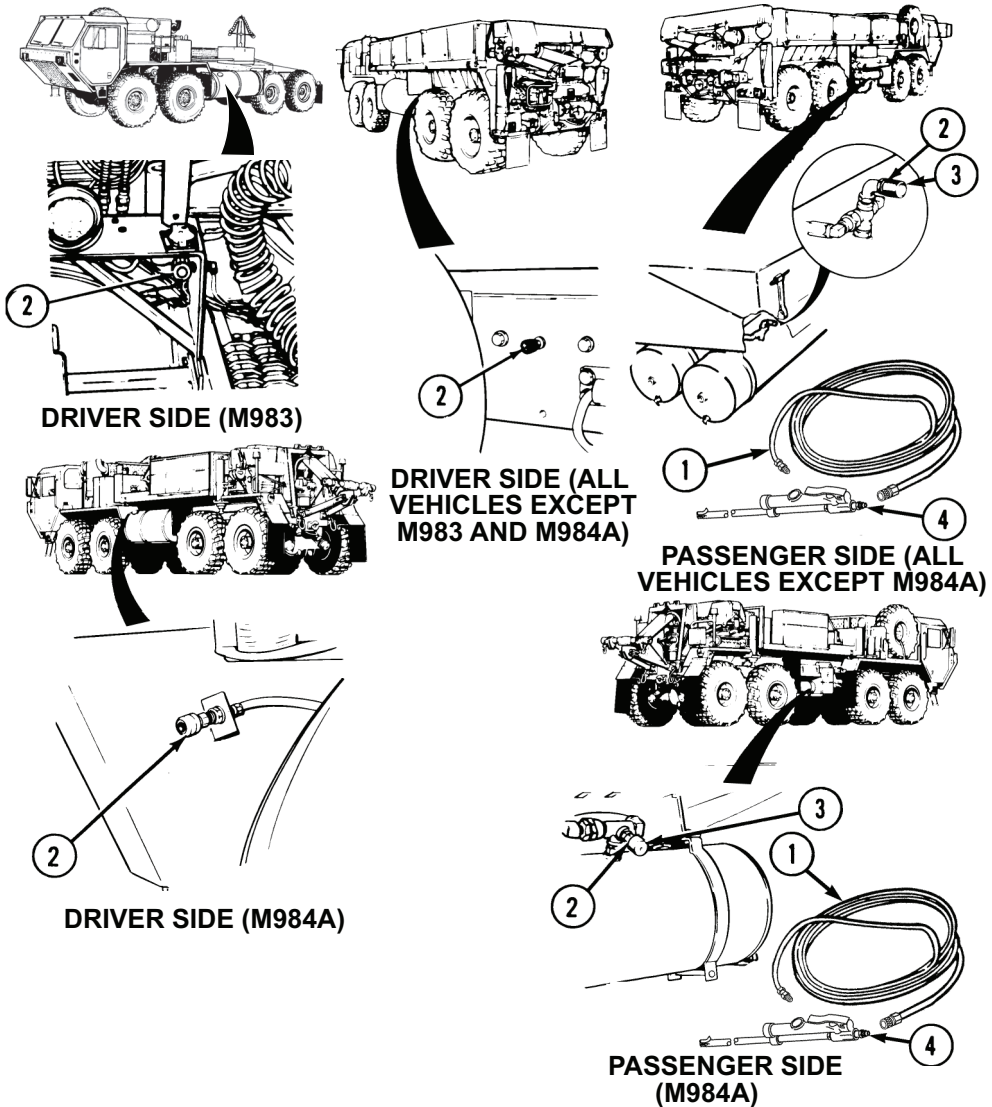

Figure 1.

2. Connect combined pressure gauge/inflation hose (4) to air hose (1).
3. Start engine. (WP 0044)

INFLATE TIRE - Continued

4. Remove valve stem cap (5) from valve stem (6).

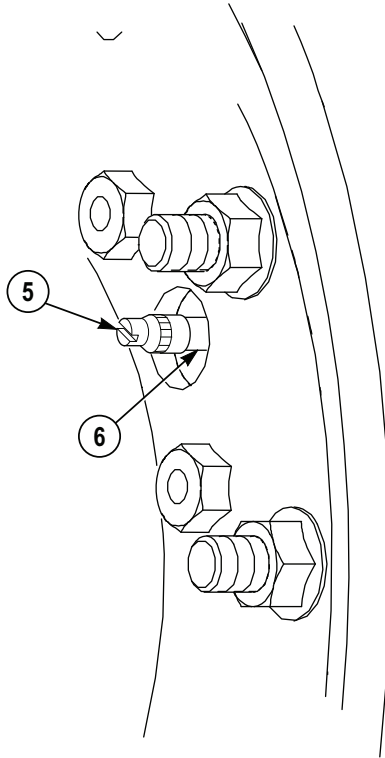

Figure 2.

WARNING

Prior to inflating or deflating tire, stand clear of trajectory area. Failure to comply may result in injury or death to personnel.

NOTE

- Trajectory area as shown applies to all wheel/tire assemblies.
- Air chuck must clamp securely with no leaks or air pressure gauge readings will be inaccurate.

INFLATE TIRE - Continued

- There are two types of air pressure gauges. One is a separate handheld gauge used on vehicle serial number 51130 and below. The other is a combined pressure gauge/inflation hose.
 - Both may be used to check air pressure in tire.
 - ALWAYS use combined pressure gauge/inflation hose to inflate tire.
5. Push latch handle (7) inward, while pushing air chuck (8) onto valve stem (6). Release latch handle (7) and immediately step out of the trajectory area and read tire air pressure gauge.

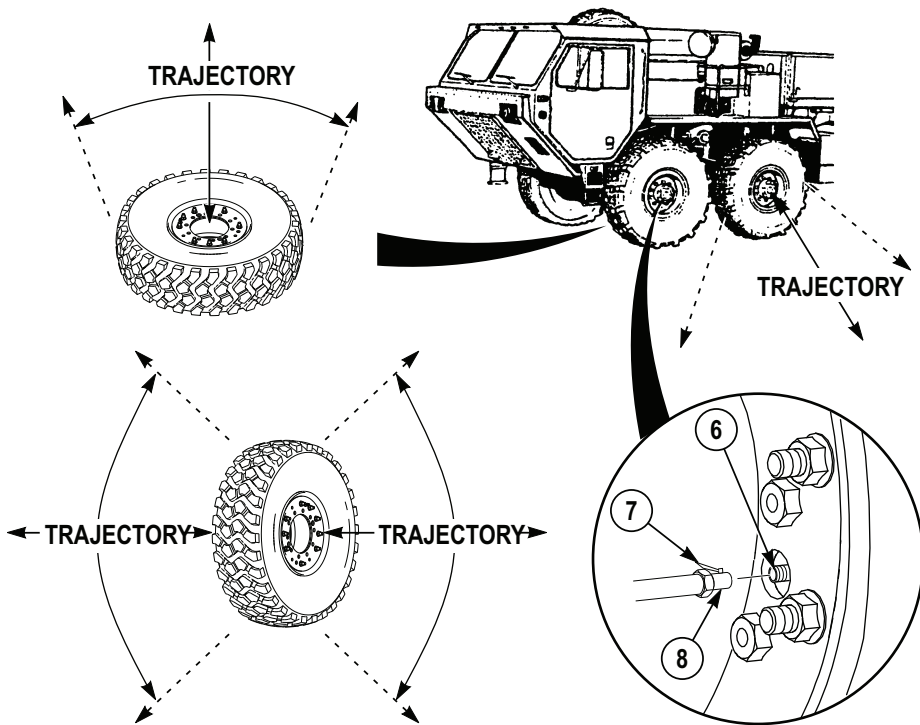
*Figure 3.*

INFLATE TIRE - Continued

WARNING



Prior to inflating or deflating tire, stand clear of trajectory area. Failure to comply may result in injury or death to personnel.

NOTE

Trajectory area as shown applies to all wheel/tire assemblies.

6. Inflate or deflate until proper pressure is attained. Press latch handle (7) and pull air chuck (8) from valve stem (6). Install valve stem cap (5).

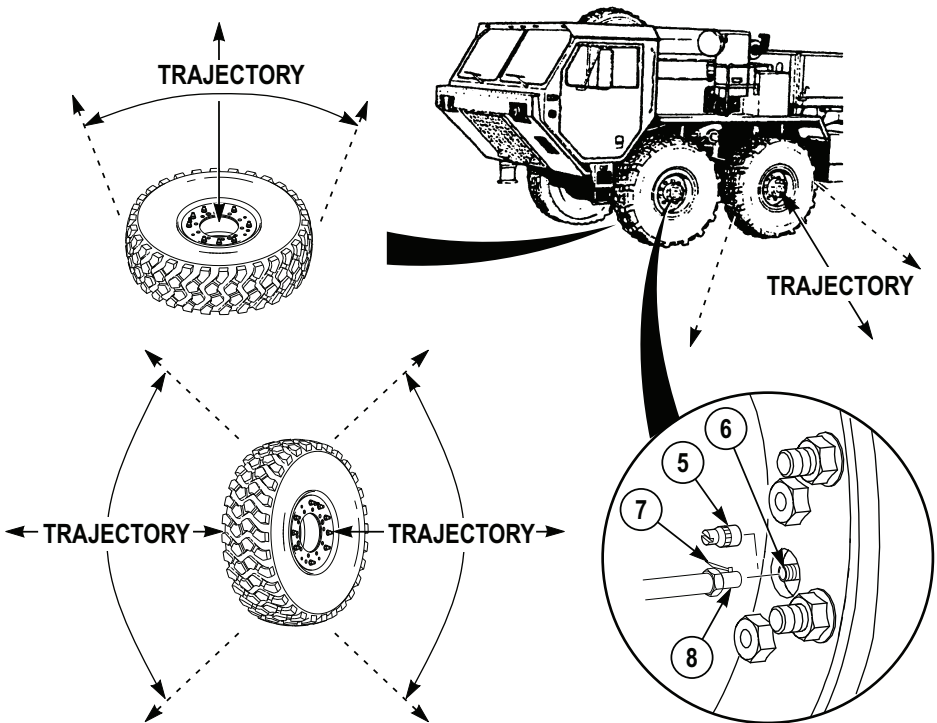

Figure 4.

7. Shut OFF engine. (WP 0057)

INFLATE TIRE - Continued**WARNING**

Hold end of air line when disconnecting from quick-disconnect coupling.
Air line is under pressure and can be ejected at a high rate of speed.
Failure to comply may result in injury or death to personnel.

8. Remove combined pressure gauge/inflation hose (4) from air hose (1).

INFLATE TIRE - Continued

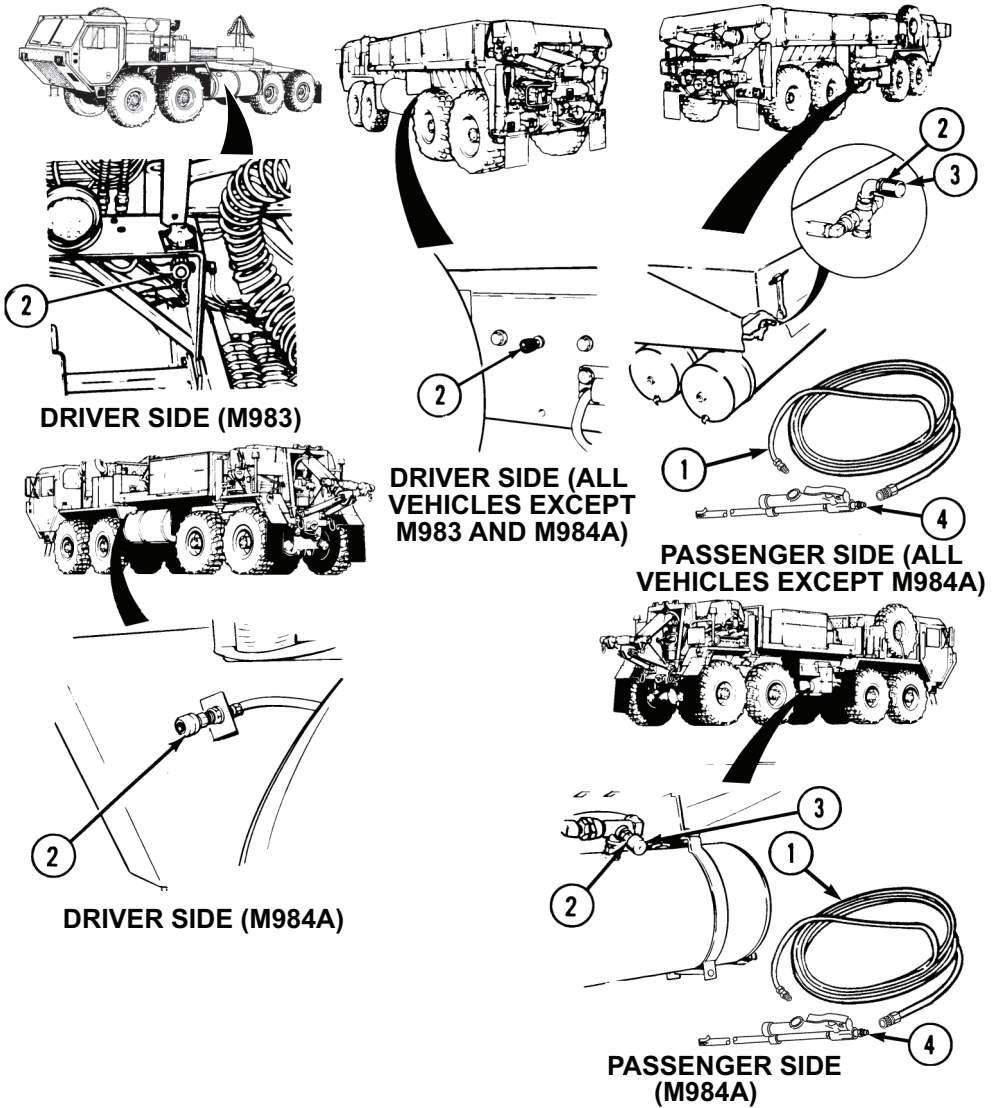

Figure 5.

9. Hold end of air hose (1) and push sleeve (3) back and remove air hose (1) from quick-disconnect coupling (2).
10. Stow air hose (1) and combined pressure gauge/inflation hose (4).

END OF TASK

FOLLOW-ON MAINTENANCE

1. Remove wheel chocks. (WP 0077)

END OF WORK PACKAGE

**OPERATOR MAINTENANCE
OPEN/CLOSE BATTERY BOX**

INITIAL SETUP:**Equipment Condition**

Engine OFF. (WP 0057)

Wheels chocked. (WP 0077)

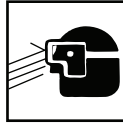
OPEN BATTERY BOX**WARNING**

Wear proper eye protection when working around batteries. Failure to comply may result in injury or death to personnel.

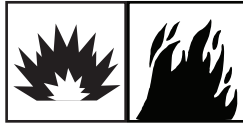
WARNING

Batteries produce explosive gases. Do not smoke or use open flame near batteries. Do not allow hot, sparking, or glowing objects near batteries. If batteries are giving off gases, presence of a heat, flame, or spark may cause fire and/or explosion. Failure to comply may result in injury or death to personnel.

WARNING

Use extreme care not to short out battery terminals. Remove all jewelry such as rings, ID tags, bracelets, etc. prior to working on or around vehicle. Jewelry and tools can catch on equipment, contact positive

OPEN BATTERY BOX - Continued

electrical circuits, and cause a direct short, severe burns, or electrical shock. Failure to comply may result in injury or death to personnel.

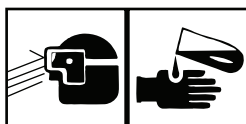
WARNING

LEAD-ACID BATTERIES - Avoid battery electrolyte contact with skin, eyes, or clothing. If battery electrolyte spills, take immediate action to stop burning effects:

- External - If battery electrolyte contacts skin, immediately flush effected area with cold running water to remove all acid. Failure to comply may result in injury or death to personnel.
- Eyes - If battery electrolyte contacts eyes, immediately flush eyes with cold water for 15 minutes and seek immediate medical attention. **IMPORTANT** - If only one eye is affected, ensure the affected eye is always (during both flushing and transport) kept lower (the lower the better) than unaffected eye. This will help keep affected eye from draining into (and contaminating) the unaffected eye. Failure to comply may result in injury or death to personnel.
- Internal - If battery electrolyte is ingested (swallowed), drink large amounts of water or milk. Follow with milk of magnesia, a beaten egg, or vegetable oil and seek immediate medical attention. Failure to comply may result in injury or death to personnel.
- Clothing or vehicle - Immediately flush area with cold water and neutralize battery electrolyte with baking soda or household ammonia solution. Failure to comply may result in injury or death to personnel.

1. Disconnect two rubber hooks (1).

OPEN BATTERY BOX - Continued

Figure 1.

2. Slide cover (2) up and out.
3. Hold cover (2) in place or remove cover.

END OF TASK**CLOSE BATTERY BOX****WARNING**

Wear proper eye protection when working around batteries. Failure to comply may result in injury or death to personnel.

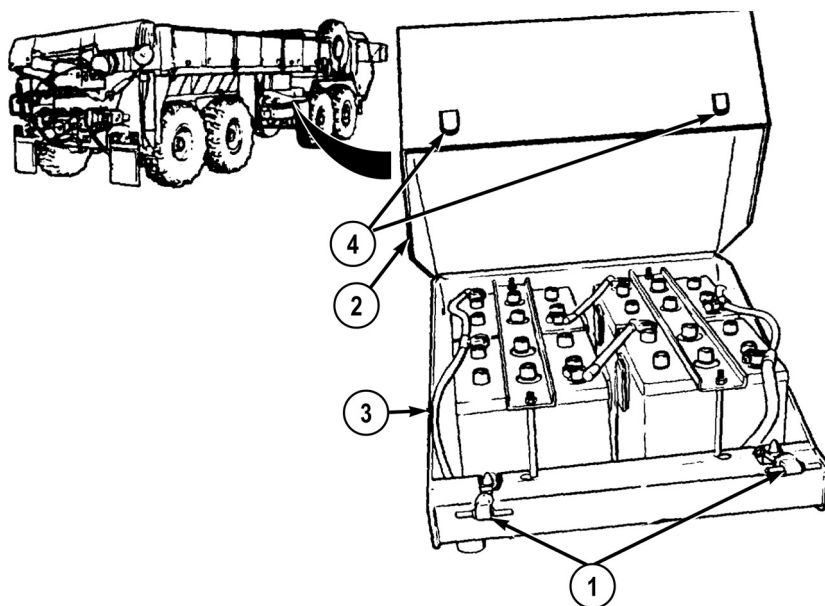
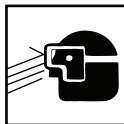
CLOSE BATTERY BOX - Continued**WARNING**

Batteries produce explosive gases. Do not smoke or use open flame near batteries. Do not allow hot, sparking, or glowing objects near batteries. If batteries are giving off gases, presence of a heat, flame, or spark may cause fire and/or explosion. Failure to comply may result in injury or death to personnel.

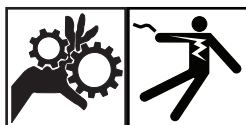
WARNING

Use extreme care not to short out battery terminals. Remove all jewelry such as rings, ID tags, bracelets, etc. prior to working on or around vehicle. Jewelry and tools can catch on equipment, contact positive electrical circuits, and cause a direct short, severe burns, or electrical shock. Failure to comply may result in injury or death to personnel.

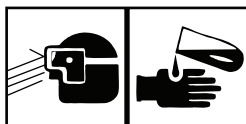
WARNING

LEAD-ACID BATTERIES - Avoid battery electrolyte contact with skin, eyes, or clothing. If battery electrolyte spills, take immediate action to stop burning effects:

- External - If battery electrolyte contacts skin, immediately flush effected area with cold running water to remove all acid. Failure to comply may result in injury or death to personnel.
- Eyes - If battery electrolyte contacts eyes, immediately flush eyes with cold water for 15 minutes and seek immediate medical attention. **IMPORTANT** - If only one eye is affected, ensure the affected eye is always (during both flushing and transport) kept lower (the lower the better) than unaffected eye. This will help keep affected eye from

CLOSE BATTERY BOX - Continued

draining into (and contaminating) the unaffected eye. Failure to comply may result in injury or death to personnel.

- Internal - If battery electrolyte is ingested (swallowed), drink large amounts of water or milk. Follow with milk of magnesia, a beaten egg, or vegetable oil and seek immediate medical attention. Failure to comply may result in injury or death to personnel.
- Clothing or vehicle - Immediately flush area with cold water and neutralize battery electrolyte with baking soda or household ammonia solution. Failure to comply may result in injury or death to personnel.

1. Slide cover (2) on battery box (3).

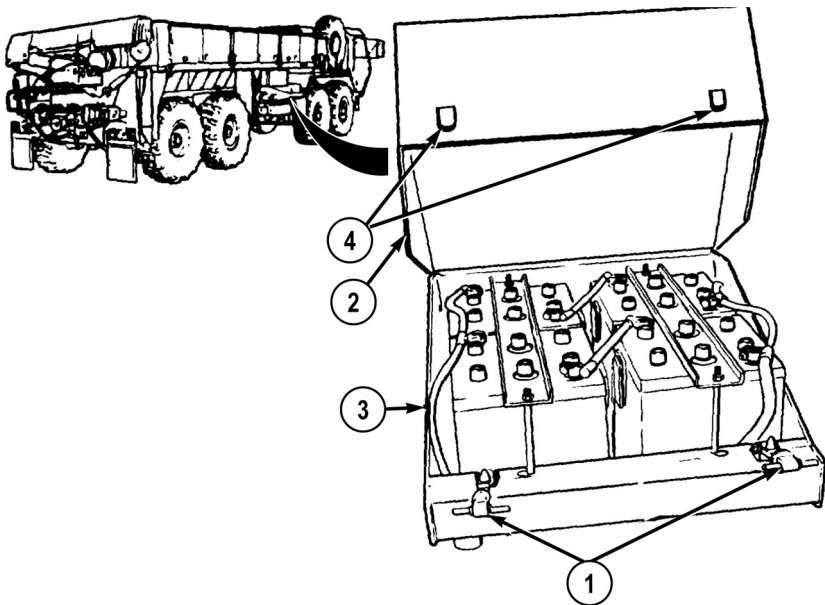

Figure 2.

2. Align rubber hooks (1) and brackets (4).
3. Connect rubber hooks (1).

END OF TASK

FOLLOW-ON MAINTENANCE

1. Remove wheel chocks. (WP 0077)

END OF WORK PACKAGE

OPERATOR MAINTENANCE
**OPEN/CLOSE ENGINE COVERS AND ENGINE SIDE PANEL REMOVAL/
INSTALLATION**

INITIAL SETUP:**Equipment Condition**

Engine OFF. (WP 0057)

Equipment Condition - ContinuedWheels chocked. (WP 0077)
Spare tire removed (if removing
passenger side engine panel).
(WP 0155)

OPEN ENGINE COVERS

1. Pull top rubber hooks (1) up and out.

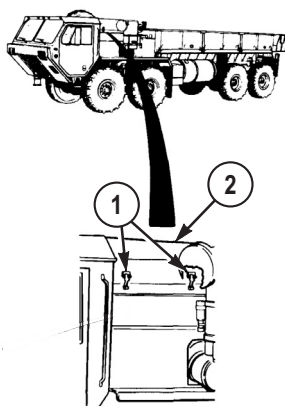

Figure 1.

2. Lift hood (2) slowly until hood (2) lies on top of engine compartment.

END OF TASK

ENGINE SIDE PANELS REMOVAL**NOTE**

- Driver side and passenger side engine side panels are removed the same way, except where noted.
- Passenger side engine side panel removal shown.

1. Pull bottom rubber hook (3) up and out.

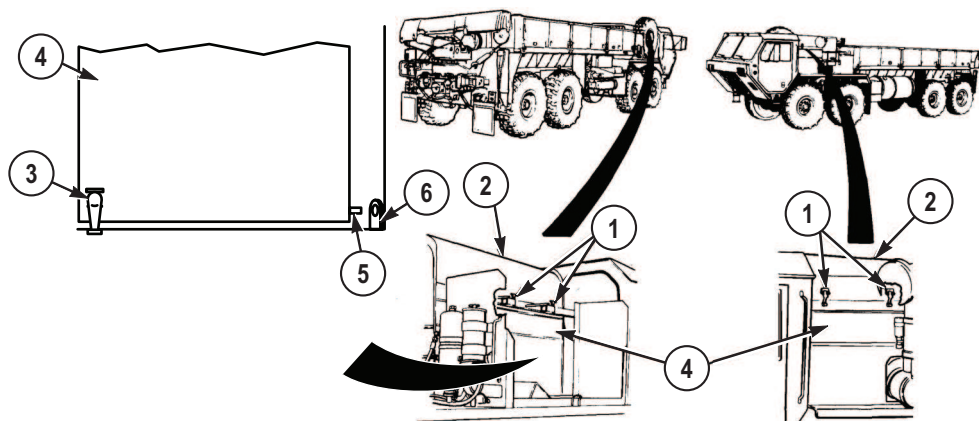
*Figure 2.*

2. Slide engine side panel (4) toward rear of vehicle so stud (5) clears mount (6).
3. Lift and remove engine side panel (4) from vehicle.

END OF TASK**ENGINE SIDE PANELS INSTALLATION**

1. Lift and install engine side panel (4) on vehicle.

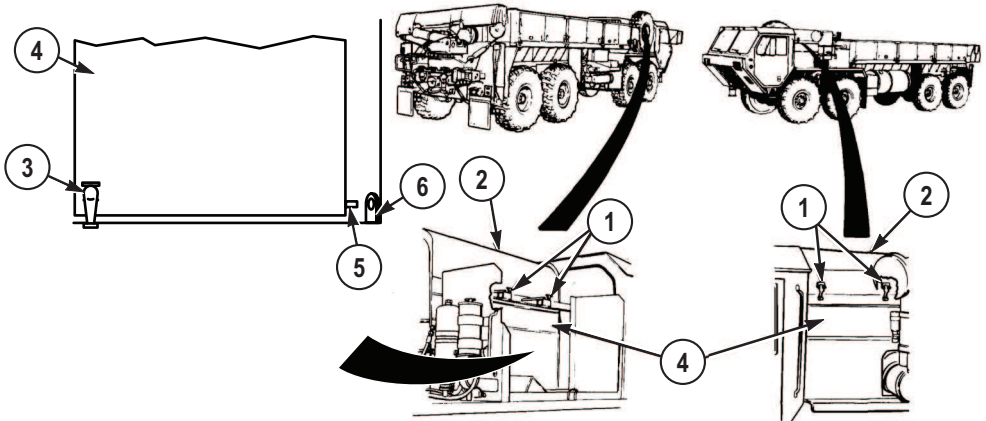
ENGINE SIDE PANELS INSTALLATION - Continued*Figure 3.*

2. Slide engine side panel (4) toward front of vehicle so stud (5) inserts into mount (6).
3. Pull bottom rubber hook (3) up and connect to engine side panel (4).

END OF TASK**CLOSE ENGINE COVERS**

1. Pull hood (2) forward.

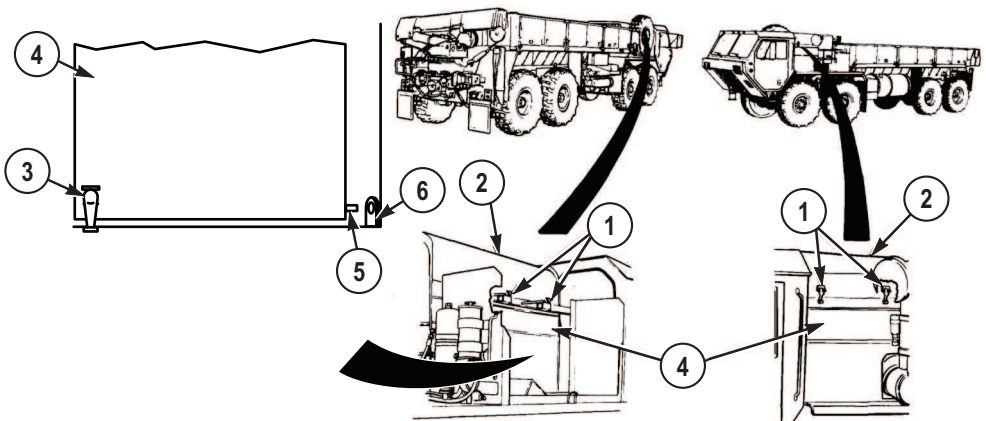
*Figure 4.*

CLOSE ENGINE COVERS - Continued

2. Push in engine side panel (4) and lower hood (2).
3. Pull top rubber hooks (1) up and connect to hood (2).

END OF TASK**END OF TASK****FOLLOW-ON MAINTENANCE**

1. Stow spare tire (if removed). (WP 0155)
2. Remove wheel chocks. (WP 0077)

END OF WORK PACKAGE

CHAPTER 6

SUPPORTING
INFORMATION

FIELD MAINTENANCE REFERENCES

SCOPE

This work package lists all pamphlets, forms, field manuals, technical manuals, and other publications referenced in this manual. Also, those publications that should be consulted for additional information about vehicle operations are listed.

DEPARTMENT OF ARMY PAMPHLETS

The following indexes should be consulted frequently for latest changes or revisions and for new publications relating to material covered in this technical manual.

DA PAM 25-30	Consolidated Index of Army Publications and Blank Forms
DA PAM 25-33	User's Guide for Army Publications and Forms
DA PAM 710-2-1	Using Unit Supply System (Manual Procedures)
DA PAM 750-8	The Army Maintenance Management System (TAMMS) Users Manual

FORMS

DA FORM 2028	Recommended Changes to Publications and Blank Forms
DA FORM 2062	Hand Receipt
DA FORM 2401	Organization Control Record for Equipment
DA FORM 2402	Maintenance Tag
DA FORM 2404	Equipment Inspection and Maintenance Worksheet
DA FORM 2407	Maintenance Request
DA FORM 2407-1	Maintenance Request Continuation Sheet
DA FORM 2408	Equipment Log Assembly (Records)
DA FORM 2408-9	Equipment Control Record
DA FORM 5988-E	Equipment Inspection Maintenance Worksheet (EGA)
DD FORM 250	Material Inspection and Receiving Report
DD FORM 314	Preventive Maintenance Schedule and Record
DD FORM 1149	Requisition and Invoice/Shipping Document
DD FORM 1348-1	DOD Single Line Item Release/Receipt Document

FORMS - Continued

DD FORM 1397	Processing and Deprocessing Record for Shipment, Storage, and Issue of Vehicles and Spare Engines
DD FORM 2282	Reinspection Decal Convention for Safe Containers
OPTIONAL FORM 346	U.S. Government Motor Vehicle Operator Identification Card
STANDARD FORM 91	Motor Vehicle Accident Report
STANDARD FORM 364	Report of Discrepancy (ROD)
STANDARD FORM 368	Product Quality Deficiency Report
STANDARD FORM 4895	Equipment Preservation Data Sheet (EPDS)

FIELD MANUALS

FM 3-6	Field Behavior of NBC Agents (Including Smoke and Incendiaries)
FM 3-11.3	Multiservice Tactics, Techniques, and Procedures For Chemical, Biological, Radiological, and Nuclear Decontamination Avoidance {MCWP 3-37.2A, NTTP 3-11.25, AFTTP(I) 3-2.56}
FM 3-11.4	Multiservice Tactics, Techniques, and Procedures For Nuclear, Biological, and Chemical (NBC) Protection {MCWP 3-37.2; NTTP 3-11.27; AFTTP (I) 3-2.46} (This Item is included on EM 0205)
FM 3-11.5	Multiservice Tactics, Techniques, and Procedures For Chemical, Biological, Radiological, and Nuclear Decontamination {MCWP 3-37.3; NTTP 3-11.26; AFTTP(I) 3-2.60}
FM 4-25.11	First Aid
FM 4-30.31	Recovery and Battle Damage Assessment and Repair
FM 5-100-15	Corps Engineer Operations
FM 5-125	Rigging Techniques, Procedures, and Applications
FM 9-207	Operation and Maintenance of Ordnance Materiel in Cold Weather
FM 10-16	General Fabric Repair
FM 10-67-1	Concepts and Equipment of Petroleum Operations
FM 20-3	Camouflage, Concealment, and Decoys
FM 21-10	Field Hygiene and Sanitation
FM 21-305	Manual for the Wheeled Vehicle Driver
FM 31-70	Basic Cold Weather Manual

FIELD MANUALS - Continued

FM 31-71	Northern Operations
FM 55-21	Railway Operating and Safety Rules
FM 55-30	Army Motor Transport Units and Operations
FM 90-3	Desert Operations
FM 90-13	River Crossing Operations

TECHNICAL BULLETINS

TB ORD 1030	Manufacture of Data Plates
TB 5-5420-234-15	Warranty Program for Common Bridge Transporter (CBT)
TB 9-2300-281-35	Standards for Oversea Shipment or Domestic Issue of Special Purpose Vehicles, Combat, Tactical, Construction, and Selected Industrial and Troop Support US Army Tank-Automotive Materiel Readiness Command Managed Items
TB 9-2300-422-20	Security of Tactical Wheeled Vehicles
TB 43-0001-62-SERIES	Equipment Improvement Report and Maintenance Digest for Tank, Automotive, and Armament Equipment
TB 43-0142	Safety Inspection and Testing of Lifting Devices
TB 43-0209	Color, Marking and Camouflage Painting of Military Vehicles, Construction Equipment, and Materials Handling Equipment
TB 43-0212	Purging, Cleaning, and Coating Interior Ferrous and Terne Sheet Vehicle Fuel Tanks
TB 43-0216	Safety and Hazard Warnings for Operation and Maintenance of TACOM Equipment
TB 750-651	Use of Antifreeze Solutions, Antifreeze Extender, Cleaning Compounds and Test Kit in Engine Cooling Systems
TB 9-289	Reconditioning of Type I and Type II Reusable Metal Containers

TECHNICAL MANUALS

TM 3-4230-214-12&P	Operator's and Unit Maintenance Manual Including Repair Parts and Special Tools List for Decontamination Apparatus
TM 3-4240-280-10	Operator's Manual for Mask, Chemical-Biological: Aircraft, ABC-M24 and Accessories and Mask, Chemical-Biological, Tank, M25A1 and Accessories (Reprinted W/Basic Incl C1-2) (This item is included on EM 0045)
TM 3-6665-225-12	Operator's and Organizational Maintenance Manual: for Alarm Chemical
TM 5-1940-277-10	Operator's Manual for Boat, Bridge Erection, Twin Jet, Aluminum Hull, Models USCSBMK 1 (NSN 1940-01-105-5728) and USCSBMK 2 (1940-01-218-9165)

TECHNICAL MANUALS - Continued

TM 5-2090-202-12&P	Operator's and Unit Maintenance Manual (Including Repair Parts and Special Tools List) for Cradle, Bridge Erection Boat, Twin Jet, Aluminum Hull (NSN 2090-01-106-9789)
TM 5-5420-208-12&P	Operator and Unit Maintenance Manual Including Repair Parts and Special Tools List for Cargo Pallet, Ribbon Bridge Transporter (NSN 5420-01-006-7436)
TM 5-5420-209-12	Operator's and Unit Maintenance Manual for Improved Float Bridge (Ribbon Bridge)
TM 5-5420-277-14&P	Operator's, Unit, Direct Support, and General Support Maintenance Manual (Including Repair Parts and Special Tools List) for Cradle, Boat, Improved, M14, (NSN 3990-01-442-1914)
TM 9-214	Inspection, Care and Maintenance of Antifriction Bearings
TM 9-243	Use and Care of Hand Tools and Measuring Tools
TM 9-1005-245-13&P	Operator's, Unit, and Direct Support Maintenance Manual with Repair Parts and Special Tools List (RPSTL) for Machine Gun Mounts and Combinations for Tactical/Armored Vehicles
TM 9-1440-600-10	Operator's Manual, Launching Station, M901 Guided Missile, Semitrailer Mount
TM 9-2320-325-10HR	Hand Receipt Covering Contents Of Components Of End Item (COEI), Basic Issue Items (BII), And Additional Authorization List (AAL) for M977 Series, 8x8 Heavy Expanded Mobility Tactical Trucks
TM 9-2330-357-14&P	Operator's, Organizational, Direct Support, and General Support Maintenance Manual (Including Repair Parts and Special Tools Lists) For Semitrailer, Flatbed, Radar Set and Launching Station M860A1 (NSN 2330-01-117-3280) (This Item Is Included On EM 0049)
TM 9-2330-385-14	Operator's, Unit, Direct Support and General Support Maintenance Manual for Palletized Load System Trailer (PLST) Model M1076 (NSN 2330-01-303-5197)
TM 9-2330-385-24P	Unit, Direct Support and General Support Maintenance Repair Parts and Special Tools List for Trailer, Palletized Load System (PLST) Model M1076 (NSN 2330-01-303-5197)
TM 9-2610-200-14	Operator's, Unit, Direct Support, and General Support Maintenance Manual for Care, Maintenance, Repair, and Inspection of Pneumatic Tires and Inner Tubes
TM 9-3990-206-14&P	Operator's Unit, Direct Support and General Support Maintenance Manual (Including Repair Parts and Special Tools List) for Palletized Load System (PLS) Flatrack Model M1077/ M1077A1

TECHNICAL MANUALS - Continued

TM 9-3990-260-14&P	Operator's, Unit, Direct Support and General Support Maintenance Manual (Including Repair Parts and Special Tools List) For Container Roll-In/Out Platform (CROP) Model M3 (NSN 3990-01-442-2751); Container Roll-In/Out Platform (CROP) Model M3A1 (3990-01-450-5671) (This Item is Included on EM 0038 and EM 0052)
TM 9-2330-366-14&P	Operator's, Organizational, Direct Support, and General Support Maintenance Including Repair Parts and Special Tools Lists For Semitrailer, Lowbed, 12-Ton, XM974 (NSN 2330-01-116-0288)
TM 9-4910-571-12&P	Operator's and Organizational Maintenance Manual (Including Repair Parts and Special Tools List) for Simplified Test Equipment for Internal Combustion Engines (STE/ICE-R)
TM 9-4910-783-13&P	Operator's, Unit, and Direct Support Maintenance Manual (Including Repair Parts and Special Tools List) for Standard Automotive Test Set (SATS)
TM 9-4940-468-13	Operator's, Unit, and Direct Support Maintenance Manual for Tool Outfit, Hydraulic Systems Test and Repair Unit (HSTRU)
TM 9-4940-568-10	Operator's Maintenance Manual for Forward Repair System (FRS)
TM 9-6115-465-24P	Unit, Direct Support and General Support Maintenance Repair Parts and Special Tools List (Including Depot Maintenance Repair Parts and Special Tools List) for Generator Set, Diesel Engine Driven, Tactical
TM 9-6140-200-14	Operator's, Unit, Direct Support and General Support Maintenance Manual for Lead-Acid Storage Batteries
TM 9-8000	Principles of Automotive Vehicles
TM 11-5820-498-12	Operator's and Organizational Maintenance Manual: Radio Sets
TM 11-5820-498-35	Direct Support, General Support, and Depot Maintenance Manual for Radio Sets
TM 38-250	Preparing Hazardous Materials for Military Air Shipments
TM 43-0139	Painting Instructions for Army Materiel
TM 55-2200-001-12	Transportability Guidance for Application of Blocking, Bracing and Tiedown Materials for Rail Transport
TM 55-2320-279-14	Transportability Guidance Heavy Expanded Mobility Tactical Truck (HEMTT)
TM 750-244-3	Procedures for Destruction of Equipment to Prevent Enemy Use (Mobility Equipment Command)
TM 750-244-6	Procedures for Destruction of Tank Automotive Equipment to Prevent Enemy Use (U.S. Army Tank-Automotive Command)
TM 750-254	Cooling Systems: Tactical Vehicles

TECHNICAL MANUALS - Continued

TM 5-2330-378-14&P	Operator's, Unit, Direct Support, and General Support Maintenance Manual (Including Repair Parts and Special Tools List) for Semitrailer, Lowbed: 40-Ton Construction Equipment Transporter, M870 (CCE) (CMI/Load King Model 403LF), and M870A1
TM 5-2330-325-14&P	Operator's, Unit, and Direct Support Maintenance Manual with Repair Parts and Special Tools List (RPSTL) for Trailer, Medium Heavy Equipment Transporter (MHET), 40-Ton, M870A3
TM 9-2330-213-14&P	Operator's, Unit, Direct Support, and General Support Maintenance Manual (Including Repair Parts and Special Tools Lists) For Trailer, Chassis: 1-1/2-Ton, 2-Wheel M103A1 (NSN 2330-00-835-8629) M103A3 (NSN 2330-00-141-8052) Trailer, Cargo: 1-1/2-Ton, 2-Wheel M105A1 (NSN 2330-00-835-8631) M105A2 (NSN 2330-00-141-8050) M105A2C (NSN 2330-00-542-5689) Trailer, Tank, Water: 1-1/2-Ton, 2-Wheel, 400-Gallon M107A1 (NSN 2330-00-835-8633) M107A2 (NSN 2330-00-141-8049) M107A2C (NSN 2330-00-542-5688) Trailer, Van, Shop: Folding Sides, 1-1/2-Ton, 2-Wheel M448 (NSN 2330-00-631-5692)
TM 9-2330-231-14&P	Technical Manual Operator's, Organizational, Direct Support, And General Support Maintenance (Including Repair Parts and Special Tools List) Trailer, Ammunition: 1 1/2-Ton, 2-Wheel, M332 (NSN 2330-00-200-1785)
TM 9-2330-368-14&P	Operators, Organizational, Including Repair Parts and Special Tools List For Trailer, Ammunition, Heavy Expanded Mobility, 11-Ton, M989 (NSN 2330-01-109-4258)
TM 5-4210-249-13&P	Operator's and Field Level Maintenance Manual with Repair Parts and Special Tools List (Including Depot Repair Parts and Special Tools) For Tactical Fire Fighting Truck (TFFT) Model M1142 NSN 4210-01-486-1035

MISCELLANEOUS PUBLICATIONS

AR 70-1	Army Acquisition Policy
AR 200-1	Environmental Protection and Enhancement
AR 385-55	Prevention of Motor Vehicle Accidents
AR 700-138	Army Logistics Readiness and Sustainability
AR 700-139	Army Warranty Program
AR 702-7	Product Quality Deficiency Report Program
AR 750-1	Army Materiel Maintenance Policy
AR 750-10	Army Modification Program

MISCELLANEOUS PUBLICATIONS - Continued

CTA 8-100	Army Medical Department Expendable/Durable Items
CTA 50-970	Expendable/Durable Items (Except Medical, Class V, Repair Parts, and Heraldic Items)
GPM 94-02	Maintenance Advisory for Purging all Fuel Tankers using a Biodegradable Purging Solution
SB 725-92-1	US Army Missile Command Nonexpendable Reusable Shipping and Storage Containers
TC 9-237	Welding Theory and Application
TC 9-510	Metal Body Repair and Related Operations
TO 00-25-234	General Shop Practice Requirements for Repair, Maintenance, and Test of Electronic Equipment

END OF WORK PACKAGE

OPERATOR MAINTENANCE COMPONENTS OF END ITEM AND BASIC ISSUE ITEMS LISTS

INTRODUCTION

Scope

This work package lists COEI and BII for the HEMTT series vehicles to help you inventory items required for safe and efficient operation.

General

The Components of End Item and Basic Issue Items Lists are divided into the following lists:

Components of End Item (COEI) This listing is for informational purposes only and is not authority for requisition replacements. These items are part of the HEMTT series vehicle. As part of the end item, these items must be with the end item whenever it is issued or transferred between property accounts. Items of COEI are removed and separately packaged for transportation or shipment only when necessary. Illustrations are furnished to help you find and identify the items.

Basic Issue Items (BII) These are the minimum essential items required to place the HEMTT series vehicle in operation, to operate it, and to perform emergency repairs. Although shipped separately packaged, BII must be with the vehicle during operation and when it is transferred between property accounts. Listing these items is your authority to request/requisition them for replacement based on your authorization of the end item by the TOE/MTOE. Illustrations are furnished to help you find and identify the items.

Explanation of Entries in the COEI List and BII List

The following provides an explanation of columns found in the tabular listings:

Item Number. Gives you the reference number of the item listed.

National Stock Number (NSN) and Illustration. Identifies the stock number of the item to be used for requisitioning purposes and provides an illustration of the item.

Description, Part Number/(CAGEC). Identifies the Federal item name (in all capital letters) followed by a minimum description when needed. The stowage location of COEI and BII is also included in this entry. The last line below the description is the part number and the Commercial and Government Entity Code (CAGEC) (in parentheses).

Usable On Code. When applicable, gives you a code if the item you need is not the same for different models of equipment. These codes are identified below:

INTRODUCTION - Continued

Table 1. List of Usable On Codes

Code	Used On
H50	M977A2 Cargo w/o winch
H51	M977A2 Cargo with winch

Column (5) - U/I Unit of Issue (U/I) U/I. Unit of Issue (U/I) indicates the physical measurement or count of the item as issued per the National Stock Number shown in column (2).

Column (6) - Qty. Indicates the quantity required.

COMPONENTS OF END ITEM

Table 2. Components of End Item



(1)	(2)	(3)	(4)	(5)	(6)
Illus No.	National Stock Number (NSN)	Description, Part Number/(CAGEC)	Usable On Code	U/I	Qty Rqr
1	6150-01-184-1901 	CABLE AND CONDUIT ASSEMBLY, ELECTRICAL: Crane (Located in passenger side stowage box) 2-198-6-00061(12361)	H51, H50	EA	1
2	2540-01-166-1384 	LADDER, VEHICLE BOARDING (Located over fuel tank on driver side of vehicle) 1766590W(45152)	H50, H51	EA	1

Table 2. Components of End Item - Continued



(1)	(2)	(3)	(4)	(5)	(6)
Illus No.	National Stock Number (NSN)	Description, Part Number/(CAGEC)	Usable On Code	U/I	Qty Rqr
3	2520-01-188-5129 	RECEIVER-TRANSMITTER, HYDRAULIC CONTROL: Crane RCU (Located in passenger side stowage box, under cargo body to rear of battery box) 2-198-6-00053(12361)	H50, H51	EA	1
4	2590-01-184-1902 	SHOE, JACK-SUPPORT: Outrigger Pad (Located on outrigger beam on rear of vehicle) 2-198-1-00028(12361)	H50, H51	EA	2

Table 3. Basic Issue Items

(1)	(2)	(3)	(4)	(5)	(6)
Illus No.	National Stock Number (NSN)	Description, Part Number/(CAGEC)	Usable On Code	U/I	Qty Rqr
1	8105-01-353-2497 	BAG, TEXTILE: Pamphlet (Located in cabin in glove box forward of passenger/crew seat) 1362710(45152)	H50, H51	EA	1

Table 3. Basic Issue Items - Continued

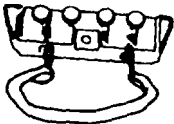

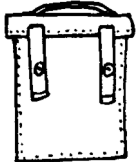

(1) Illus No.	(2) National Stock Number (NSN)	(3) Description, Part Number/(CAGEC)	(4) Usable On Code	(5) U/I	(6) Qty Rqr
2	7510-00-889-3494 	BINDER, LOOSE-LEAF (Located on passenger side of cab in glove box) 11677003(19207)	H50, H51	EA	1
3	3940-01-163-2319 	BLOCK, TACKLE: 20 Ton (Located in driver side tool box) 168400(75535)	H51	EA	1
4	6150-01-180-6035 	CABLE ASSEMBLY, POWER, ELECTRICAL: Worklamp (Located in driver side tool box) 1419770U(45152)	H50, H51	EA	1
5	6150-01-320-0719 	CABLE ASSEMBLY, SPECIAL PURPOSE, ELECTRICAL: Worklamp (Located in driver side tool box) 1771530W(45152)	H50, H51	EA	1

Table 3. Basic Issue Items - Continued



(1) Illus No.	(2) National Stock Number (NSN)	(3) Description, Part Number/(CAGEC)	(4) Usable On Code	(5) U/I	(6) Qty Rqr
6	4010-01-200-1506 	CHAIN ASSEMBLY, SINGLE LEG: 7 ft. Limp Home (Located in driver side tool box) 1452490(45152)	H50, H51	EA	1
7	4010-01-249-0548 	CHAIN ASSEMBLY, SINGLE LEG: 14 ft. Utility (Located in driver side tool box) 00044-9973(96508)	H50, H51	EA	1
8	2540-01-165-6136 	CHOCK, WHEEL- TRACK (Located in wheel chock stowage box [carries a maximum of two wheel chocks], vehicle mounted stowage boxes, and/or under spare tire) CS-2540-0067(16236)	H50, H51	EA	4

Table 3. Basic Issue Items - Continued

(1) Illus No.	(2) National Stock Number (NSN)	(3) Description, Part Number/(CAGEC)	(4) Usable On Code	(5) U/I	(6) Qty Rqr
9	4210-01-133-9053 	EXTINGUISHER, FIRE: 2.7 lbs, 10 BC (Located in cabin to right of driver's seat) 429101(03670)	H50, H51	EA	1
10	6545-00-922-1200 	FIRST AID KIT, GENERAL PURPOSE (Located in cabin in glove box forward of passenger/crew seat) SCC-6545- ILVOL2(64616)	H50, H51	EA	1
11	4910-01-003-9599 	GAUGE, TIRE PRESSURE, SELF- CONTAINED (Located in cabin in glove box forward of passenger/ crew seat) 61-J2-1506(94894)	H50, H51	EA	2

Table 3. Basic Issue Items - Continued

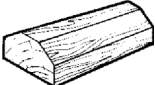

(1) Illus No.	(2) National Stock Number (NSN)	(3) Description, Part Number/(CAGEC)	(4) Usable On Code	(5) U/I	(6) Qty Rqr
12	5340-01-209-7841 	HANDLE, EXTENSION (for lug wrench) (Located in driver side tool box) 1347720(45152)	H50, H51	EA	1
13	5120-01-233-9508 	HANDLE, SOCKET WRENCH: Wheel Lugnut (Located in driver side toolbox) ORR301(66784)	H50, H51	EA	1
14	4720-01-558-6415 	HOSE ASSEMBLY, NONMETALLIC: Air 50 ft. 2155210U(45152)	H50, H51	EA	2

Table 3. Basic Issue Items - Continued

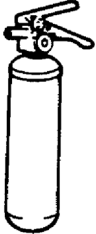
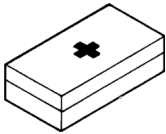
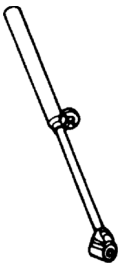

(1) Illus No.	(2) National Stock Number (NSN)	(3) Description, Part Number/(CAGEC)	(4) Usable On Code	(5) U/I	(6) Qty Rqr
15	4910-01-386-4300 	INFLATOR-GAUGE, PNEUMATIC TIRE (Located in cabin in glove box forward of passenger/crew seat) I-405M(63900)	H50, H51	EA	2
16	5120-01-146-8096 	JACK, HYDRAULIC, HAND: 12 Ton with Handle (Located in driver side tool box) EBJ-12GC(26952)	H50, H51	EA	1
17	5340-00-158-3807 	PADLOCK: With Chain (for stowage boxes) AA59487-2SC(58536)	H51, H50	EA	4

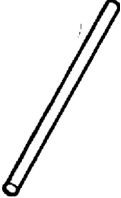
Table 3. Basic Issue Items - Continued

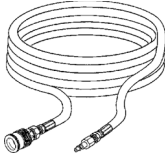
(1) Illus No.	(2) National Stock Number (NSN)	(3) Description, Part Number/(CAGEC)	(4) Usable On Code	(5) U/I	(6) Qty Rqr
18	5340-00-158-3805 	PADLOCK: Without Chain (for steering column) (Located in steering column lock bracket under dash) AA59487-2S(58536)	H50, H51	EA	1
19	2540-01-165-5987 	PLATE, BASE, JACK (Located in driver side toolbox) 2540V0730(16236)	H50, H51	EA	1
20	5120-01-480-0640 	PLIERS, SLIP JOINT: 10 in. Adjustable (Located in driver side toolbox - part of tool roll) 1350150(45152)	H50, H51	EA	1
21	9905-01-480-0644 	REFLECTOR SET, HIGHWAY WARNING, TRIANGULAR (Located in cabin mounted under glove box forward of passenger/crew seat) 6432GBX(45152)	H50, H51	SE	1

Table 3. Basic Issue Items - Continued

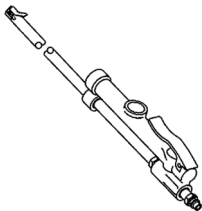
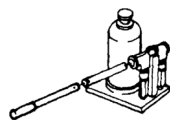

(1) Illus No.	(2) National Stock Number (NSN)	(3) Description, Part Number/(CAGEC)	(4) Usable On Code	(5) U/I	(6) Qty Rqr
22	5140-01-167-1541 	ROLL, TOOLS AND ACCESSORIES (Located in driver side storage box) 1350190(45152)	H50, H51	EA	1
23	5120-01-398-8053 	SCREWDRIVER, CROSS TIP: Phillips No. 3 (Located in driver side toolbox - part of tool roll) SDFP56(96508)	H50, H51	EA	1
24	5120-00-293-3309 	SCREWDRIVER, FLAT TIP: No. 6 (Located in driver side toolbox - part of tool roll) 66-110(03914)	H50, H51	EA	1
25	4030-00-377-1397 	SHACKLE: Anchor, Limp Home (Located in driver side toolbox) RR-C-271 TY4AGRBCL2SZ 1.000(81348)	H50, H51	EA	1

Table 3. Basic Issue Items - Continued

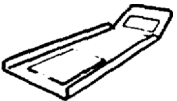
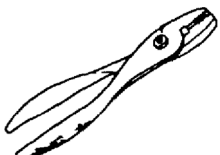
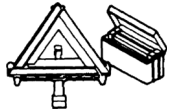

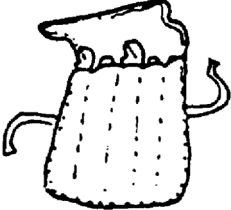
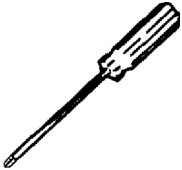

(1) Illus No.	(2) National Stock Number (NSN)	(3) Description, Part Number/(CAGEC)	(4) Usable On Code	(5) U/I	(6) Qty Rqr
26	4030-01-316-1552 	SHACKLE: Towing: (Located on front and rear towing eyes) RR-C-271D TYIVAGRACL1 3/8 IN(81348)	H50, H51	EA	4
27	3940-01-209-6008 	SLING AND WIRE ROPE ASSEMBLY SET (Located in driver side equipment body, top forward stowage box) AC 2000 00331(28620)	H50, H51	EA	1
28	6220-01-326-2286 	SPOTLIGHT: Worklamp 1401182(78422)	H50, H51	EA	1
29	1670-00-725-1437 	TIEDOWN, CARGO 10045035(18876)	H51, H50	EA	24

Table 3. Basic Issue Items - Continued

(1) Illus No.	(2) National Stock Number (NSN)	(3) Description, Part Number/(CAGEC)	(4) Usable On Code	(5) U/I	(6) Qty Rqr
30	5120-01-436-2924 	WRENCH, ADJUSTABLE: 8 in. (Located in driver side toolbox - part of tool roll) AC18(96508)	H50, H51	EA	1
31	5120-00-264-3796 	WRENCH, ADJUSTABLE: 12 in. (Located in driver side toolbox - part of tool roll) 120405A(45152)	H50, H51	EA	1
32	5120-01-070-8386 	WRENCH, SOCKET: Wheel Nut (Located in driver side tool box) 1048-TR(45152)	H50, H51	EA	1

END OF WORK PACKAGE

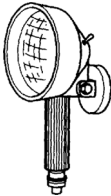
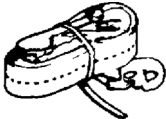
OPERATOR MAINTENANCE ADDITIONAL AUTHORIZATION LIST (AAL)

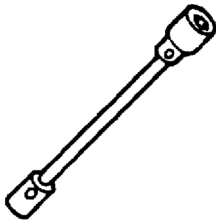
Introduction

Scope

This work package lists additional authorization items that are needed to operate and maintain the HEMTT Series Vehicles.

General

This list identifies items that do not have to accompany the HEMTT Series Vehicles and that do not have to be turned in with it. These items are all authorized to you by CTA, MTOE, TDA, or JTA.

Explanation of Columns in the AAL

Column (1) - National Stock Number (NSN). Identifies the stock number of the item to be used for requisitioning purposes.

Column (2) - Description, Part Number/(CAGEC). Identifies the Federal item name (in all capital letters) followed by a minimum description when needed. The last line below the description is the part number and the Commercial and Government Entity Code (CAGEC) (in parentheses).

Column (3) - Usable On Code. When applicable, gives you a code if the item you need is not the same for different models of equipment.

Table 1. List of Usable On Codes

Code	Used On
H50	M977A2 Cargo w/o winch
H51	M977A2 Cargo with winch

Column (4) - U/I. Unit of Issue (U/I) indicates the physical measurement or count of the item as issued per the National Stock Number.

Column (5) - Qty Recm. Indicates the quantity recommended.

Table 2. Additional Authorization List

(1) National Stock Number (NSN)	(2) Description, Part Number/ (CAGEC)	(3) Usable On Code	(4) U/I	(5) Qty Recom
5110-00-293-2 336	AXE, SINGLE BIT 6150925(19207)	H50, H51	EA	1
4910-00-347-9 703	BAR ASSEMBLY, HOISTING 8690061(52793)	H50, H51	EA	1
3940-01-247-3 682	BEAM, HOISTING: DOUBLE AC200000364(28620)	H50	EA	1
3940-01-247-3 681	BEAM, HOISTING: SINGLE AC200000354(28620)	H50	EA	1
2510-00-741-7 585	BOARD GROUND JACK 7417585(19207)	H50, H51	EA	2
2540-00-409-8 891	BRACKET ASSEMBLY, TOOL: PIONEER MS53053-1(96906)	H50, H51	EA	1
6150-01-022-6 004	CABLE ASSEMBLY, POWER, ELECTRICAL: NATO 11682336-1(19207)	H50, H51	EA	1
2540-01-152-7 813	CHAIN, TIRE, EMERGENCY 2624-10-8(46156)	H50, H51	PR	2
2540-01-198-7 409	COVER, FITTED, VEHICULAR BODY: CARGO BODY COVER 2178120U(45152)	H50, H51	EA	1
4230-01-220-3 221	DECONTAMINATION KIT, INDIVIDUAL EQUIPMENT 5705588(19207)	H50, H51	EA	1

Table 2. Additional Authorization List - Continued

(1) National Stock Number (NSN)	(2) Description, Part Number/ (CAGEC)	(3) Usable On Code	(4) U/I	(5) Qty Recom
5130-01-400-0 129	EXTENSION, SOCKET WRENCH: IMPACT 3/4 in. DRIVE, 13 in. LONG 07569(1CV05)	H50, H51	EA	1
4240-01-220-6 373	GAS PARTICULATE KIT 3SK663(45152)	H50, H51	KT	1
8415-00-634-4 658	GLOVES, LEATHER 37G2940(90142)	H50, H51	PR	2
5120-00-288-6 574	HANDLE, MATTOCK-PICK 10501973(56161)	H50, H51	EA	1
2990-01-509-1 954	HEATER, COOLANT, ENGINE: ARCTIC 3460259(45152)	H50, H51	EA	1
3940-01-247-3 681	HOISTING BEAM, SINGLE AC200000354(28620)	H50	EA	1
4720-01-341-4 912	HOSE ASSEMBLY 1759750U(45152)	H50, H51	EA	1
4720-01-254-0 189	HOSE ASSEMBLY, NONMETALLIC: INTER- VEHICULAR MS39325-9-140-8(96906)	H50, H51	EA	2
5895-01-506-4 503	INSTALLATION KIT, ELECTRONIC EQUIPMENT: C4ISR 3418900(45152)	H50, H51	EA	1

Table 2. Additional Authorization List - Continued

(1) National Stock Number (NSN)	(2) Description, Part Number/ (CAGEC)	(3) Usable On Code	(4) U/I	(5) Qty Recom
1005-01-519-2 126	INSTALLATION KIT: MOUNTING, MACHINE GUN 1301740UW/OR45152	H50, H51	KT	1
6665-01-220-3 220	KIT, CHEMICAL ALARM 5705589(19207)	H50, H51	KT	1
6220-01-250-5 190	LIGHT, WARNING: BEACON 3145661(45152)	H50, H51	EA	1
5120-00-243-2 395	MATTOCK: PICK 11677022(19207)	H50, H51	EA	1
5120-00-892-5 709	MIRROR, INSPECTION UH1487(11676)	H50, H51	EA	1
1005-01-266-1 233	MOUNT, RIFLE: INSTALLATION 5705590(19207)	H50, H51	EA	1
5120-00-197-9 473	PUNCH, BLACKSMITH'S: 17 in. 647008(60903)		EA	1
4030-01-316-1 552	SHACKLE: TOWING (used with towbar, 10 ton) 1307540(45152)	H50, H51	EA	2
5120-00-293-3 336	SHOVEL: HAND 11655784(19207)	H50, H51	EA	1
3940-01-209-6 008	SLING AND WIRE ROPE ASSEMBLY SET AC 2000 00331(28620)	H51	EA	1
3940-00-040-2 297	SLING, MULTIPLE LEG 8330151(19207)	H51	EA	1

Table 2. Additional Authorization List - Continued

(1) National Stock Number (NSN)	(2) Description, Part Number/ (CAGEC)	(3) Usable On Code	(4) U/I	(5) Qty Recom
3940-01-083-9 313	SLING, MULTIPLE LEG SW71M(91796)	H50	EA	1
3940-01-241-7 400	SLING, MULTIPLE LEG AC200000332(28620)	H50	EA	1
3940-01-270-3 389	SLING, MULTIPLE LEG: 16 FT. SAFETY CHAINtwo (2) 16 ft. safety chains should be used in conjunction with Tow Bar: 10 Ton NSN: 2540-00-378-2012, P/N: 8383802, C/C: 19207. 1482010(45152)	H50, H51	EA	2
5130-01-400-0 164	SOCKET, SOCKET WRENCH (3/4 in. drive, 1 3/4 in. hex, impact) J07528L(1CV05)	H50, H51	EA	1
3990-01-204-3 009	TIE DOWN, CARGO, VEHICLE MIL-PRF-71224-1(OHK26)	H50, H51	EA	8
2540-00-378-2 012	TOW BAR, MOTOR VEHICLE: 10 tonShould be used in conjunction with two (2) safety chains: 16 ft. NSN: 3940-01-270-3389, P/N: 1482010, C/C: 45152. 8383802(19207)	H50, H51	EA	1
5130-01-428-3 751	WRENCH, IMPACT, PNEUMATIC 1789100U(45152)	H50, H51	EA	1

END OF WORK PACKAGE

OPERATOR MAINTENANCE EXPENDABLE AND DURABLE ITEMS LIST

Introduction

Scope

This work package lists expendable supplies and materials that are needed to operate and maintain the HEMTT Series Vehicles. This list is for information only and is not authority to requisition the listed items. These items are authorized to you by CTA 50-970, Expendable/Durable Items (Except Medical, Class V Repair Parts, and Heraldic Items), CTA 50-909, Field and Garrison Furnishings and Equipment or CTA 8-100, Army Medical Department Expendable/Durable Items.

Explanation of Entries in the Expendable/Durable Items List

Item No. This number is assigned to the entry in the list and is referenced in the narrative instructions to identify the item (e.g., Use brake fluid (Expendable/Durable Items List)).

Level. This column identifies the lowest level of maintenance that requires the listed item.

- C -- Operator/Crew
- O -- Unit/AMC
- F -- Direct Support/ASB
- H -- General Support
- D -- Depot

National Stock Number (NSN). This is the NSN assigned to the item which you can use to requisition it.

Item Name, Description, Part Number/(CAGEC). This column provides the other information you need to identify the item. The last line below the description is the part number and the Commercial and Government Entity Code (CAGEC) (in parentheses).

(U/I). Unit of Issue (U/I) code shows the physical measurement or count of an item, such as gallon, dozen, gross, etc.

Table 1. Expendable and Durable Items List

(1)	(2)	(3)	(4)	(5)
Item No.	Level	National Stock Number (NSN)	Item Name, Description, Part Number/ (CAGEC)	U/I

Table 1. Expendable and Durable Items List - Continued

(1) Item No.	(2) Level	(3) National Stock Number (NSN)	(4) Item Name, Description, Part Number/ (CAGEC)	(5) U/I
			Antifreeze, Arctic Type	
1	C	6850-01-464-9096	Antifreeze, Arctic Type 55-gal drum A-A-52624 (58536)	DR
			Antifreeze, Permanent, Glycol, Inhibited	
2	C	6850-01-464-9125	Antifreeze, Permanent, Glycol, Inhibited 1-gal container AA52624 (58536)	GL
3	C	6850-00-464-9137	Antifreeze, Permanent, Glycol, Inhibited 5-gal container MILA46153 (81349)	CO
4	C	6850-01-464-9152	Antifreeze, Permanent, Glycol, Inhibited 55-gal drum A-A-52624 TY I RECYCLED (58536)	DR
			Cleaner, Lubricant	
5	C	9150-01-079-6124	Cleaner, Lubricant A, 4 oz bottle w/ extender tube MIL-PRF-63460 (81349)	BT
			Cleaning Compound, Solvent	
6	C	6850-01-474-2319	Cleaning Compound, Solvent 1 gallon can MIL-PRF-680 Type II (81349)	GL
7	C	6850-01-474-2317	Cleaning Compound, Solvent 5 gallon can MIL-PRF-680 Type II (81349)	CO

Table 1. Expendable and Durable Items List - Continued

(1) Item No.	(2) Level	(3) National Stock Number (NSN)	(4) Item Name, Description, Part Number/ (CAGEC)	(5) U/I
8	C	6850-01-474-2 316	Cleaning Compound, Solvent 55 gallon drum MIL-PRF-680 Type II (81349)	DR
9	C	6850-01-474-2 318	Cleaning Compound, Solvent 1 gallon can MIL-PRF-680 Type III (81349)	GL
10	C	6850-01-474-2 320	Cleaning Compound, Solvent 5 gallon can MIL-PRF-680 Type III (81349)	BX
11	C	6850-01-474-2 321	Cleaning Compound, Solvent 5 gallon can MIL-PRF-680 Type III (81349)	DR
			Compound, Cleaning Windshield	
12	C	6850-00-926-2 275	Compound, Cleaning Windshield 1-pt can 0854-000 (0FTT5)	BX
			Fuel, DF-1, Winter	
13	C	9140-01-413-7 511	Fuel, DF-1, Winter Bulk VV-F-800 (81348)	GL
14	C	9140-00-286-5 286	Fuel, DF-1, Winter Bulk ASTM D 975 (81346)	GL
15	C	9140-00-286-5 287	Fuel, DF-1, Winter 5-gal can ASTM D 975 (81346)	CN
16	C	9140-00-286-5 288	Fuel, DF-1, Winter 55-gal drum, 16 gauge ASTM D 975 (81346)	DR
17	C	9140-00-286-5 289	Fuel, DF-1, Winter 55-gal drum, 18 gauge ASTM D 975 (81346)	DR

Table 1. Expendable and Durable Items List - Continued

(1) Item No.	(2) Level	(3) National Stock Number (NSN)	(4) Item Name, Description, Part Number/ (CAGEC)	(5) U/I
			Fuel	
18	C	9130-01-031-5816	Fuel, JP8 Bulk MILT83133 GR JP8 (81349)	GL
19	C	9140-01-412-1311	Fuel, DF-2, Regular Bulk VV-F-800 (81348)	GL
20	C	9140-00-286-5294	Fuel, DF-2, Regular Bulk ASTM D 975 (81346)	GL
21	C	9140-00-286-5295	Fuel, DF-2, Regular 5-gal can ASTM D 975 (81346)	CN
22	C	9140-00-286-5296	Fuel, DF-2, Regular 55-gal drum, 16 gauge ASTM D 975 (81346)	DR
23	C	9140-00-286-5297	Fuel, DF-2, Regular 55-gal drum, 18 gauge ASTM D 975 (81346)	DR
			Grease, Automotive and Artillery GAA	
24	C	9150-01-197-7688	Grease, Automotive and Artillery GAA 2-1/2 oz tube M-10924-A (81349)	TU
25	C	9150-01-197-7693	Grease, Automotive and Artillery GAA 14-oz cartridge M-10924-B (81349)	CA
26	C	9150-01-197-7690	Grease, Automotive and Artillery GAA 1-lb can M-10924-C (81349)	CN

Table 1. Expendable and Durable Items List - Continued

(1) Item No.	(2) Level	(3) National Stock Number (NSN)	(4) Item Name, Description, Part Number/ (CAGEC)	(5) U/I
27	C	9150-01-197-7 689	Grease, Automotive and Artillery GAA 5-lb can M-10924-D (81349)	CN
28	C	9150-01-197-7 692	Grease, Automotive and Artillery GAA 35-lb can M-10924-E (81349)	CN
			Oil, Lubricating Gear, GO 75 (MIL-L-2105)	
29	C	9150-01-035-5 390	Oil, Lubricating Gear, GO 75 (MIL-L-2105) 1-qt can M2105-1-75W (81349)	QT
30	C	9150-01-035-5 391	Oil, Lubricating Gear, GO 75 5-gal can MIL-PRF-2105 (81349)	CN
			Oil, Lubricating Gear, GO 80W/90 (MIL-L-2105C)	
31	C	9150-01-035-5 393	Oil, Lubricating Gear, GO 80W/90 (MIL-L-2105C) 5-gal can J2360 (81343)	CN
			Oil, Lubricating OEA Ice, Subzero	
32	C	9150-00-403-2 372	Oil, Lubricating OEA Ice, Subzero 1-qt can EMERY3908D (33358)	QT
33	C	9150-00-402-2 372	Oil, Lubricating OEA Ice, Subzero 5-gal can MIL-PRF-46167 (81349)	CN

Table 1. Expendable and Durable Items List - Continued

(1) Item No.	(2) Level	(3) National Stock Number (NSN)	(4) Item Name, Description, Part Number/ (CAGEC)	(5) U/I
34	C	9150-00-491-7197	Oil, Lubricating OEA Ice, Subzero 55-gal drum, 16 gauge MIL-PRF-46167 (81349)	DR
			Oil, Lubricating OE/HDO 10	
35	C	9150-01-518-9471	Oil, Lubricating OE/HDO 10 1-qt can M2104-1-10W (81349)	QT
36	C	9150-00-186-6668	Oil, Lubricating OE/HDO 10 5-gal can M2104-3-10W (81349)	CN
37	C	9150-00-191-2772	Oil, Lubricating OE/HDO 10 55-gal drum, 18 gauge M2104-4-10W (98308)	DR
			Oil, Lubricating OE/HDO 30, (SAE 30)	
38	C	9150-01-496-1962	Oil, Lubricating OE/HDO 30, (SAE 30) Bulk M2104-2-30W (81349)	GL
39	C	9150-00-186-6681	Oil, Lubricating OE/HDO 30, (SAE 30) 1-qt can M2104-3-30W (81349)	QT
40	C	9150-00-188-9858	Oil, Lubricating OE/HDO 30, (SAE 30) 5-gal can MIL-PRF-2104 (81349)	CN
41	C	9150-01-433-7978	Oil, Lubricating OE/HDO 30, (SAE 30) 55-gal can M2104-4-30W (81349)	DR
42	C	9150-01-433-7978	Oil, Lubricating OE/HDO 30, (SAE 30) 55-gal drum, 18 gauge M2104-4-30W (81349)	DR

Table 1. Expendable and Durable Items List - Continued

(1) Item No.	(2) Level	(3) National Stock Number (NSN)	(4) Item Name, Description, Part Number/ (CAGEC)	(5) U/I
			Oil, Lubricating OE/HDO 50	
43	C	9150-00-188-9865	Oil, Lubricating OE/HDO 50 5-gal drum BRAYC0423H (98308)	CN
			Oil, Lubricating Gear, GO 85W/140	
44	C	9150-01-035-5396	Oil, Lubricating Gear, GO 85W/140 55-gallon drum J2360 (81343)	DR
45	C	9150-01-035-5395	Oil, Lubricating Gear, GO 85W/140 5-gallon can J2360 (81343)	CN
			Oil, Lubricating, Internal Combustion Engine, Tactical Service OE/HDO 15W/40 (MIL-L-2104)	
46	C	9150-01-421-1432	Oil, Lubricating, Internal Combustion Engine, Tactical Service OE/HDO 15W/40 (MIL-L-2104) 55-gal drum, 18 gauge M2104-5-15W40 (81349)	DR
47	C	9150-01-518-9477	Oil, Lubricating, Internal Combustion Engine, Tactical Service OE/HDO 15W/40 (MIL-L-2104) 1-quart can M2104-1-15W40 (81349)	QT
48	C	9150-01-421-1427	Oil, Lubricating, Internal Combustion Engine, Tactical Service OE/HDO 15W/40 (MIL-L-2104) 24-quart box MIL-PRF-2104 (81349)	QT

Table 1. Expendable and Durable Items List - Continued

(1) Item No.	(2) Level	(3) National Stock Number (NSN)	(4) Item Name, Description, Part Number/ (CAGEC)	(5) U/I
			Oil, Lubricating, OE/HDO 40	
49	C	9150-00-188-9862	Oil, Lubricating, OE/HDO 40 55-gal drum MIL-PRF-2104 (81349)	DR
			Rag, Wiping	
50	C	7920-00-205-1711	Rag, Wiping 50-pound bale 7920-00-205-1711 (80244)	BE
			Rope	
51	C	4020-00-968-1357	Rope, Fibrous MIL-R-17343 (81349)	RL
			Oil, Lubricating, Preventative	
52	C	9150-01-293-7696	Oil, Lubricating, Preventative 5-gal drum MIL-L-21260C (81349)	CN
53	C	9150-01-438-6079	Oil, Lubricating, Preventative 55-gallon drum J2363 (81349)	DR

END OF WORK PACKAGE

RECOMMENDED CHANGES TO PUBLICATIONS AND BLANK FORMS For use of this form, see AR 25-30; the proponent agency is OAASA						Use Part II (<i>reverse</i>) for Repair Parts and Special Tool Lists (RPSTL) and Supply Catalogs/Supply Manuals (SC/SM).	DATE Date you filled out this form.	
TO: (<i>Forward to proponent of publication or form</i>) (<i>Include ZIP Code</i>) TACOM Life Cycle Management Command ATTN: AMSTA-LC-LMPP/TECH PUBS, 1 Rock Island Arsenal, Rock Island, IL 61299-7630						FROM: (<i>Activity and location</i>) (<i>Include ZIP Code</i>) Your mailing address		
PART I - ALL PUBLICATIONS (EXCEPT RPSTL AND SC/SM) AND BLANK FORMS								
PUBLICATION/FORM NUMBER TM 9-2320-347-10						DATE 15 May 09	TITLE Operator Manual for Truck, Cargo, 8x8 M977A2 w/Winch and M977A2 w/o Winch	
ITEM	PAGE	PARA-GRAPH	LINE	FIGURE NO.	TABLE	RECOMMENDED CHANGES AND REASON		
<h1>SAMPLE</h1>								
<i>* Reference to line numbers within the paragraph or subparagraph.</i>								
TYPED NAME, GRADE OR TITLE Your Name						TELEPHONE EXCHANGE/AUTOVON, PLUS EXTENSION 		SIGNATURE Your Signature

TO: <i>(Forward direct to addressee listed in publication)</i> TACOM Life Cycle Management Command ATTN: AMSTA-LC-LMPP/TECH PUBS, 1 Rock Island Arsenal, Rock Island, IL 61299-7630	FROM: <i>(Activity and location) (Include ZIP Code)</i>	DATE
---	--	-------------

PART II - REPAIR PARTS AND SPECIAL TOOL LISTS AND SUPPLY CATALOGS/SUPPLY MANUALS

PUBLICATION NUMBER TM 9-2320-347-10	DATE 15 May 09	TITLE Operator Manual for Truck, Cargo, 8x8 M977A2 w/Winch and M977A2 w/o Winch
---	--------------------------	--

PAGE NO.	COLM NO.	LINE NO.	NATIONAL STOCK NUMBER	REFERENCE NO.	FIGURE NO.	ITEM NO.	TOTAL NO. OF MAJOR ITEMS SUPPORTED	RECOMMENDED ACTION
SAMPLE								

PART III - REMARKS *(Any general remarks or recommendations, or suggestions for improvement of publications and blank forms. Additional blank sheets may be used if more space is needed.)*

TYPED NAME, GRADE OR TITLE	TELEPHONE EXCHANGE/AUTOVON, PLUS EXTENSION	SIGNATURE
-----------------------------------	---	------------------

RECOMMENDED CHANGES TO PUBLICATIONS AND BLANK FORMS For use of this form, see AR 25-30; the proponent agency is OAASA						Use Part II (<i>reverse</i>) for Repair Parts and Special Tool Lists (RPSTL) and Supply Catalogs/Supply Manuals (SC/SM).	DATE
TO: (<i>Forward to proponent of publication or form</i>) (<i>Include ZIP Code</i>) TACOM Life Cycle Management Command ATTN: AMSTA-LC-LMPP/TECH PUBS, 1 Rock Island Arsenal, Rock Island, IL 61299-7630						FROM: (<i>Activity and location</i>) (<i>Include ZIP Code</i>)	
PART I - ALL PUBLICATIONS (EXCEPT RPSTL AND SC/SM) AND BLANK FORMS							
PUBLICATION/FORM NUMBER TM 9-2320-347-10						DATE 15 May 09	TITLE Operator Manual for Truck, Cargo, 8x8, M977A2 w/Winch and M977A2 w/o Winch
ITEM	PAGE	PARA-GRAPH	LINE	FIGURE NO.	TABLE	RECOMMENDED CHANGES AND REASON	
<i>* Reference to line numbers within the paragraph or subparagraph.</i>							
TYPED NAME, GRADE OR TITLE					TELEPHONE EXCHANGE/AUTOVON, PLUS EXTENSION		SIGNATURE

TO: <i>(Forward direct to addressee listed in publication)</i> TACOM Life Cycle Management Command ATTN: AMSTA-LC-LMPP/TECH PUBS, 1 Rock Island Arsenal, Rock Island, IL 61299-7630	FROM: <i>(Activity and location) (Include ZIP Code)</i>	DATE
---	--	-------------

PART II - REPAIR PARTS AND SPECIAL TOOL LISTS AND SUPPLY CATALOGS/SUPPLY MANUALS

PUBLICATION NUMBER TM 9-2320-347-10	DATE 15 May 09	TITLE Operator Manual for Truck, Cargo, 8x8, M977A2 w/Winch and M977A2 w/o Winch
---	--------------------------	---

PAGE NO.	COLM NO.	LINE NO.	NATIONAL STOCK NUMBER	REFERENCE NO.	FIGURE NO.	ITEM NO.	TOTAL NO. OF MAJOR ITEMS SUPPORTED	RECOMMENDED ACTION

PART III - REMARKS *(Any general remarks or recommendations, or suggestions for improvement of publications and blank forms. Additional blank sheets may be used if more space is needed.)*

TYPED NAME, GRADE OR TITLE	TELEPHONE EXCHANGE/AUTOVON, PLUS EXTENSION	SIGNATURE
-----------------------------------	---	------------------

RECOMMENDED CHANGES TO PUBLICATIONS AND BLANK FORMS						Use Part II (<i>reverse</i>) for Repair Parts and Special Tool Lists (RPSTL) and Supply Catalogs/Supply Manuals (SC/SM).	DATE
For use of this form, see AR 25-30; the proponent agency is OAASA							
TO: (<i>Forward to proponent of publication or form</i>) (<i>Include ZIP Code</i>) TACOM Life Cycle Management Command ATTN: AMSTA-LC-LMPP/TECH PUBS, 1 Rock Island Arsenal, Rock Island, IL 61299-7630				FROM: (<i>Activity and location</i>) (<i>Include ZIP Code</i>)			
PART I - ALL PUBLICATIONS (EXCEPT RPSTL AND SC/SM) AND BLANK FORMS							
PUBLICATION/FORM NUMBER TM 9-2320-347-10				DATE 15 May 09	TITLE Operator Manual for Truck, Cargo, 8x8, M977A2 w/Winch and M977A2 w/o Winch		
ITEM	PAGE	PARA- GRAPH	LINE	FIGURE NO.	TABLE	RECOMMENDED CHANGES AND REASON	
* Reference to line numbers within the paragraph or subparagraph.							
TYPED NAME, GRADE OR TITLE				TELEPHONE EXCHANGE/AUTOVON, PLUS EXTENSION		SIGNATURE	

TO: <i>(Forward direct to addressee listed in publication)</i> TACOM Life Cycle Management Command ATTN: AMSTA-LC-LMPP/TECH PUBS, 1 Rock Island Arsenal, Rock Island, IL 61299-7630	FROM: <i>(Activity and location) (Include ZIP Code)</i>	DATE
---	--	-------------

PART II - REPAIR PARTS AND SPECIAL TOOL LISTS AND SUPPLY CATALOGS/SUPPLY MANUALS

PUBLICATION NUMBER TM 9-2320-347-10	DATE 15 May 09	TITLE Operator Manual for Truck, Cargo, 8x8, M977A2 w/Winch and M977A2 w/o Winch
---	--------------------------	---

PAGE NO.	COLM NO.	LINE NO.	NATIONAL STOCK NUMBER	REFERENCE NO.	FIGURE NO.	ITEM NO.	TOTAL NO. OF MAJOR ITEMS SUPPORTED	RECOMMENDED ACTION

PART III - REMARKS *(Any general remarks or recommendations, or suggestions for improvement of publications and blank forms. Additional blank sheets may be used if more space is needed.)*

TYPED NAME, GRADE OR TITLE	TELEPHONE EXCHANGE/AUTOVON, PLUS EXTENSION	SIGNATURE
-----------------------------------	---	------------------

By Order of the Secretary of the Army:

GEORGE W. CASEY, JR.
General, United States Army
Chief of Staff

Official:



JOYCE E. MORROW
Administrative Assistant to the
Secretary of the Army
0809904

DISTRIBUTION: To be distributed in accordance with the initial distribution requirements for IDN: 381193, requirements for TM 9-2320-347-10.

TM 9-2320-347-10

THE METRIC SYSTEM AND EQUIVALENTS

LINEAR MEASURE

1 Centimeter = 10 Millimeters = 0.01 Meters = 0.3937 Inches
 1 Meter = 100 Centimeters = 1000 Millimeters = 39.37 Inches
 1 Kilometer = 1000 Meters = 0.621 Miles

SQUARE MEASURE

1 Sq Centimeter = 100 Sq Millimeters = 0.155 Sq Inches
 1 Sq Meter = 10,000 Sq Centimeters = 10.76 Sq Feet
 1 Sq Kilometer = 1,000,000 Sq Meters = 0.386 Sq Miles

WEIGHTS

1 Gram = 0.001 Kilograms = 1000 Milligrams = 0.035 Ounces
 1 Kilogram = 1000 Grams = 2.2 Lb
 1 Metric Ton = 1000 Kilograms = 1 Megagram = 1.1 Short Tons

CUBIC MEASURE

1 Cu Centimeter = 1000 Cu Millimeters = 0.06 Cu Inches
 1 Cu Meter = 1,000,000 Cu Centimeters = 35.31 Cu Feet

LIQUID MEASURE

1 Milliliter = 0.001 Liters = 0.0338 Fluid Ounces
 1 Liter = 1000 Milliliters = 33.82 Fluid Ounces

TEMPERATURE

$5/9 (^{\circ}\text{F} - 32) = ^{\circ}\text{C}$
 212° Fahrenheit is equivalent to 100° Celsius
 90° Fahrenheit is equivalent to 32.2° Celsius
 32° Fahrenheit is equivalent to 0° Celsius
 $9/5 \text{ C}^{\circ} + 32 = \text{F}^{\circ}$

APPROXIMATE CONVERSION FACTORS

<u>TO CHANGE</u>	<u>TO</u>	<u>MULTIPLY BY</u>
Inches	Centimeters	2.540
Feet	Meters	0.305
Yards	Meters	0.914
Miles	Kilometers	1.609
Square Inches	Square Centimeters	6.451
Square Feet	Square Meters	0.093
Square Yards	Square Meters	0.836
Square Miles	Square Kilometers	2.590
Acres	Square Hectometers	0.405
Cubic Feet	Cubic Meters	0.028
Cubic Yards	Cubic Meters	0.765
Fluid Ounces	Milliliters	29.573
Pints	Liters	0.473
Quarts	Liters	0.946
Gallons	Liters	3.785
Ounces	Grams	28.349
Pounds	Kilograms	0.454
Short Tons	Metric Tons	0.907
Pound-Feet	Newton-Meters	1.356
Pounds/Sq Inch	Kilopascals	6.895
Miles per Gallon	Kilometers per Liter	0.425
Miles per Hour	Kilometers per Hour	1.609

<u>TO CHANGE</u>	<u>TO</u>	<u>MULTIPLY BY</u>
Centimeters	Inches	0.394
Meters	Feet	3.280
Meters	Yards	1.094
Kilometers	Miles	0.621
Sq Centimeters	Square Inches	0.155
Square Meters	Square Feet	10.764
Square Meters	Square Yards	1.196
Square Kilometers	Square Miles	0.386
Sq Hectometers	Acres	2.471
Cubic Meters	Cubic Feet	35.315
Cubic Meters	Cubic Yards	1.308
Milliliters	Fluid Ounces	0.034
Liters	Pints	2.113
Liters	Quarts	1.057
Liters	Gallons	0.264
Grams	Ounces	0.035
Kilograms	Pounds	2.205
Metric Tons	Short Tons	1.102
Newton-Meters	Pound-Feet	0.738
Kilopascals	Pounds per Sq Inch	0.145
Km per Liter	Miles per Gallon	2.354
Km per Hour	Miles per Hour	0.621

